

HYDROSTRESS

®

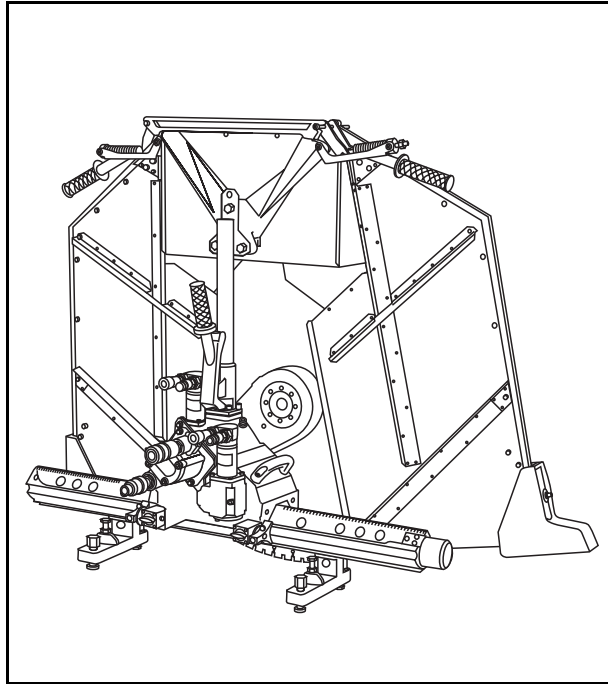

DZ-S2 wall sawing system

Index 000

Operating instructions

Spare parts list

0.1 Introduction

Dear Customer,

You have decided to buy a Hydrostress system and have thus acquired a highly sophisticated and reliable state-of-the-art unit.

Due to our special efforts in the field of quality assurance, the DZ-S2 wall sawing system is a further Swiss, top-of-the-range product with the following properties:

- High sawing performance
- Reliable operation
- High portability
- Easy handling
- Low maintenance costs

The exclusive use of genuine Hydrostress spare parts ensures quality and interchangeability.

In the case of neglected or inappropriate maintenance, we refuse to accept any warranty commitment as specified in our terms of delivery.

Any repair work is to be carried out by trained personnel only.

Should you need more details concerning your Hydrostress system in order to keep it in perfect condition, please contact our after-sales service for further information.

We hope that you will not experience any problems while working with your Hydrostress system.

TYROLIT Hydrostress AG

Management

Copyright © HYDROSTRESS AG, May 2002

TYROLIT Hydrostress AG Witzbergstrasse 18 CH-8330 Pfäffikon Switzerland Phone ++41 (0)44 952 18 18 Fax ++41 (0)44 952 18 00
--

0.2 Validity of this manual

This operating manual is only valid for the following system:

DZ-S2 wall sawing system Index 000

0.3 Standards

This operating manual has been prepared in accordance with CE Machinery Directive Appendix I and with the relevant standards in force at the time of printing.

0.4 Delimitation of the system

This operating manual also describes how to use to the blade guard and the rail system.

Drive unit operating instructions.

Notes in this manual referring to the operation of drive units are designed to increase the safety of the operating personnel. To ensure that drive units are operated safely, however, it is essential to refer to the appropriate manual.

0.5	Table of contents		6	Anchoring saw blade for normal cutting	24
0.1	Introduction	2	7	Anchoring saw blade for flush cutting	25
0.2	Validity of this manual	2	8	Connecting the drive units	26
0.3	Standards	2	9	Sawing	27
0.4	Delimitation of the system	2	9.1	Before sawing	27
0.5	Table of contents	3	9.2	The first cut (precut)	27
1	Safety instructions	4	9.3	After the first cut	28
1.1	Fundamentals	4	9.4	Terminating the work	29
1.2	Before starting work	7	10	Troubleshooting	30
1.3	During sawing	8	11	Maintenance	32
1.4	After the work	8	11.1	Maintenance table	32
2	Technical data	9	11.2	Change prism guides	33
2.1	Dimensions	9	11.3	Change feed motor	33
2.2	Measurements	9	11.4	Exchange swivelling motor	33
3	Range of applications	10	11.5	Change gear grease	34
3.1	Connectable units	10	11.6	Toothed belt tensioning	35
3.2	Possible applications	10	11.7	Tensioning the toothed belt	35
4	Design and function	11	11.8	Exchanging toothed belt	36
4.1	Wall sawing system design	11	11.9	Repair	36
4.2	Safety components	11	12	Transport, taking out of service, storage, disposal	37
4.3	Rail system	11	12.1	Transport	37
4.4	Wall saw head design	11	12.2	Taking out of service and storage	37
4.5	Function	12	12.3	Disposal	37
4.6	Controls and connections	14	13	Accessories	38
4.7	Function (table)	15	13.1	Accessories available to order	38
5	Set-up	16	13.2	Hydraulic drive motors	38
5.1	Initial start-up	16	14	Spare parts list	39
5.2	Preparatory operations	16	14.1	Ordering information	39
5.3	Selecting the saw blade	17			
5.4	Replacing saw motor	19			
5.5	Mounting V-rails on concrete	20			
5.6	Fitting wall saw head	22			
5.7	Adjustment / Taking up play	23			
5.8	Removing the slide guides	23			

1 Safety instructions

1.1 Fundamentals

Qualification of operating personnel

Processing concrete is neither simple nor without risk. Material assets on the site, the machine itself and the safety of people are at stake.

The operating personnel must therefore be trained by experienced specialists. HYDROSTRESS can support you in your training.

Read the manual and inform your staff

This manual contains important information on how to operate the machine safely and efficiently.

The owner of the machine must make sure that the instructions in this manual are followed by anyone who has anything to do with the machine or the respective auxiliary and operating resources.

The manual must be available at all times where the machine is being used.

Hazards on the building site

The machine has been built in accordance with state-of-the-art standards and the recognized safety regulations. Nevertheless, its use may constitute a risk to the life and limb of the user or of third parties, or cause damage to the machine and to other property.

Pay attention to the particular working conditions on the building site. Protect yourself thoroughly and others under your responsibility against the many hazards!

Noise level

Depending on the working environment, the machine can cause excessive noise during operation. The noise can permanently harm the hearing of operating personnel and of other people nearby within a short time. Ear protectors must therefore always be worn while working.

Recognize warning signs

Pay attention to the following words, their symbol and their meaning:

Danger



Orders or prohibitions designed to prevent injury to personnel and material damage

Warning:

Orders or prohibitions designed to prevent ***damage to the machine***

Important:

Information on how to ***use*** the machine ***efficiently***.

Safety clothing

Safety clothing must always be worn when drilling, sawing, nibbling or compressing concrete or stone in order to protect against the following hazards:

Sources of danger	Protective clothing
Falling parts:	Helmet, steel-capped safety shoes
Moving, sharp-edged parts:	Safety gloves
Flying pieces of stone, flying sparks:	Safety glasses
Slipping:	Anti-slip shoes
Noise:	Ear protectors
Contamination of respiratory tracts:	Respiratory mask

Materials suitable for processing

Only the following materials are to be machined by HYDROSTRESS equipment:

- **Concrete and natural stone.**

Other materials are **not to be processed**.

Especially do not process:

- Wood, plastics and glass

Concrete and stone cutouts or drilling cores

These pieces can be very heavy.

1m³= 2400-2700 kg

Example:

A cube of concrete measuring 0.5 by 0.5 by 0.5 m weighs about 300 kg. A drilling core with a diameter of 30 cm and a length of 1 m weighs about 180 kg.

Make sure that these pieces cannot fall or tip over and cordon off the hazardous area.

Safety components

Never start up the machine without fitting the correct safety components (see “Safety components” section of these operating instructions manual).

Controls and accessories

Use the machine only with the recommended controllers or devices and accessories (see “Connectable Controls” and “Accessories” in this manual).

Local safety regulations

Pay attention to the general and specific safety regulations of your local trade associations.

1.2 Before starting work

Emergency stop

Make sure you know how to stop the machine quickly in case of emergency (see “Emergency stop” in this manual)!

First aid in case of accidents

Make sure you know how to alert first aid rapidly in case of an accident.

Water, gas and electric lines

Make sure that all supply lines are turned off in the area of your cut or drill hole! Find out whether it is permissible for such lines to be cut through.

Reinforcing rods

Make sure that it is safe and permitted to cut reinforcing rods in the area of your cut or drill hole.

Organising your workplace

Organise your workplace well. You will reduce the risk of accidents substantially.

Lighting of your workplace

Make sure you have sufficient lighting at your workplace.

Safe areas for operating personnel and other people

This machine is designed for one-person operation.

During processing, other people must keep at a safe distance from the machine.

The drive unit controller must be positioned so that all the operator’s controls are within easy reach.

It must be possible at any time to stop the machine rapidly and safely (see “Emergency stop”).

1.3 During sawing

Always fasten the saw blade with the screws supplied. Make sure you use screws of the correct dimensions and grade.

Never use saw blades with cracks! Cracked saw blades may break during sawing and endanger you and other people.

Motorized feed

Machines with motorized feed *are not* automatic machines. They must never be left unattended during operation. An emergency stop must be possible at all times.

Rotating and moving parts

To prevent being caught by rotating or moving parts, wear close-fitting clothes and a hair net if you have long hair.

1.4 After the work

When using electric drive units

Unplug the machine from the mains immediately after processing in order to prevent the drive unit being switched on unintentionally!

Removing concrete and stone sections

Use appropriate lifting gear to remove these sections, in order to prevent injuries.

2 Technical data

2.1 Dimensions

Weights

27 kg	Wall saw, incl. feed motors excluding saw motor
5.50 kg	Saw motor size 2

Blade drive

Hydraulic motor	440 - 3640 rpm.
Ratio	1:2
Operating pressure	max. 260 bar

Movement

Hydraulic motor	-
Operating pressure	max. 100 bar
Feed force	max. 600 kg
Feed	Toothed wheel on rail

Swivelling

Hydraulic motor	-
Operating pressure	max. 100 bar
Swivelling range	360°
Feed force	300 kg

Rails

Length	70 cm
	110 cm
	140 cm
	180 cm
	220 cm
Hole spacing	10 cm

Cutting depths

Dia. 800 mm	no precut	31 cm
Dia. 900 mm	no precut	35 cm
Dia. 1000 mm	with precut	40 cm
Dia. 1200 mm	with precut	50 cm

2.2 Measurements

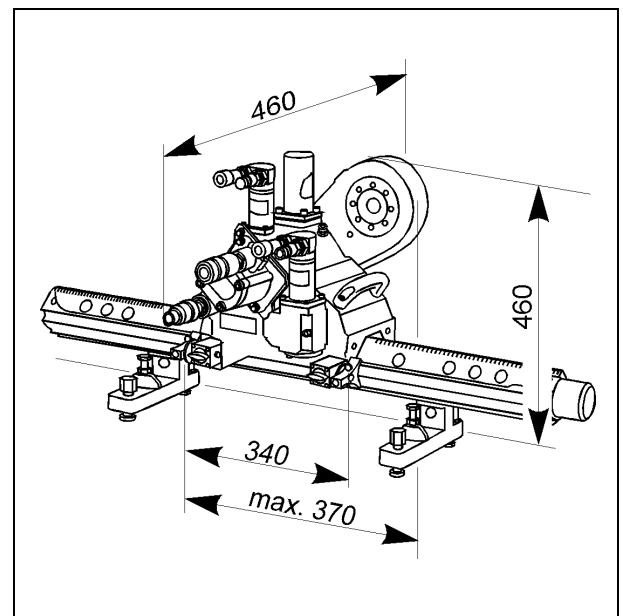

3 Range of applications

3.1 Connectable units

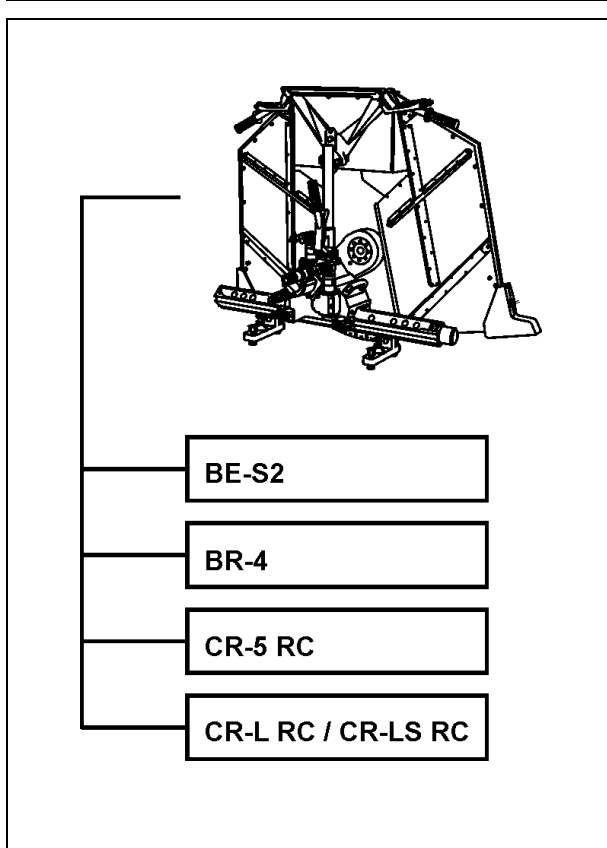

Special features of the various drive units

The drive units vary in their performance. For optimum cutting performance the correct saw motor must be selected (see “Selecting saw motor”) according to the unit used and the planned application.

BE-S2	1 motorised feed with feed module only
BR-4	1 stage
CR-5 RC	4 stages
CR-L RC / CR-LS RC	1 stage

3.2 Possible applications

- Parting cuts
- Flush cuts
- Inclined cuts
- Joint cuts



This machine is not designed for other applications and may be cause particular hazards under specific circumstances.

4 Design and function

4.1 Wall sawing system design

The DZ-S2 wall sawing system comprises:

- Wall saw head
- Blade guard
- Rail system

Wall saw head

The wall saw head contains all the hydraulic and mechanical parts for:

- Blade drive
- Travelling motion
- 360° swivelling motion

4.2 Safety components

Blade guard, three-piece, collapsible

- folding
- removable side wing
- 800mm, 1000mm or 1200mm, normal and flush
- in aluminium

4.3 Rail system

- Anchoring to concrete with clamping block and dowel screw

4.4 Wall saw head design

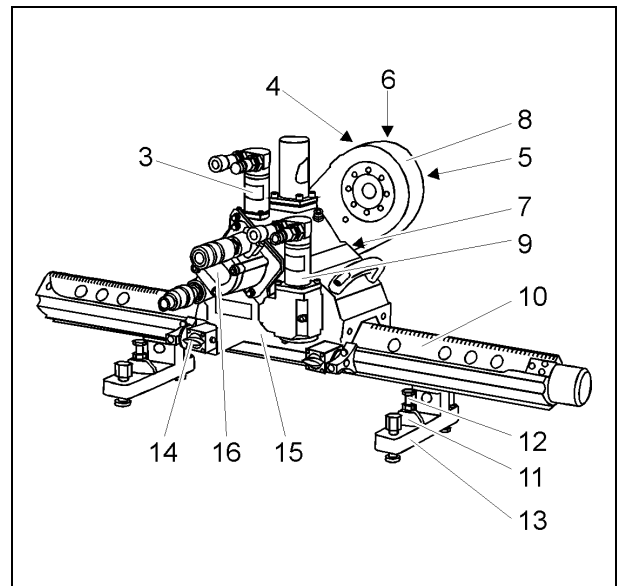

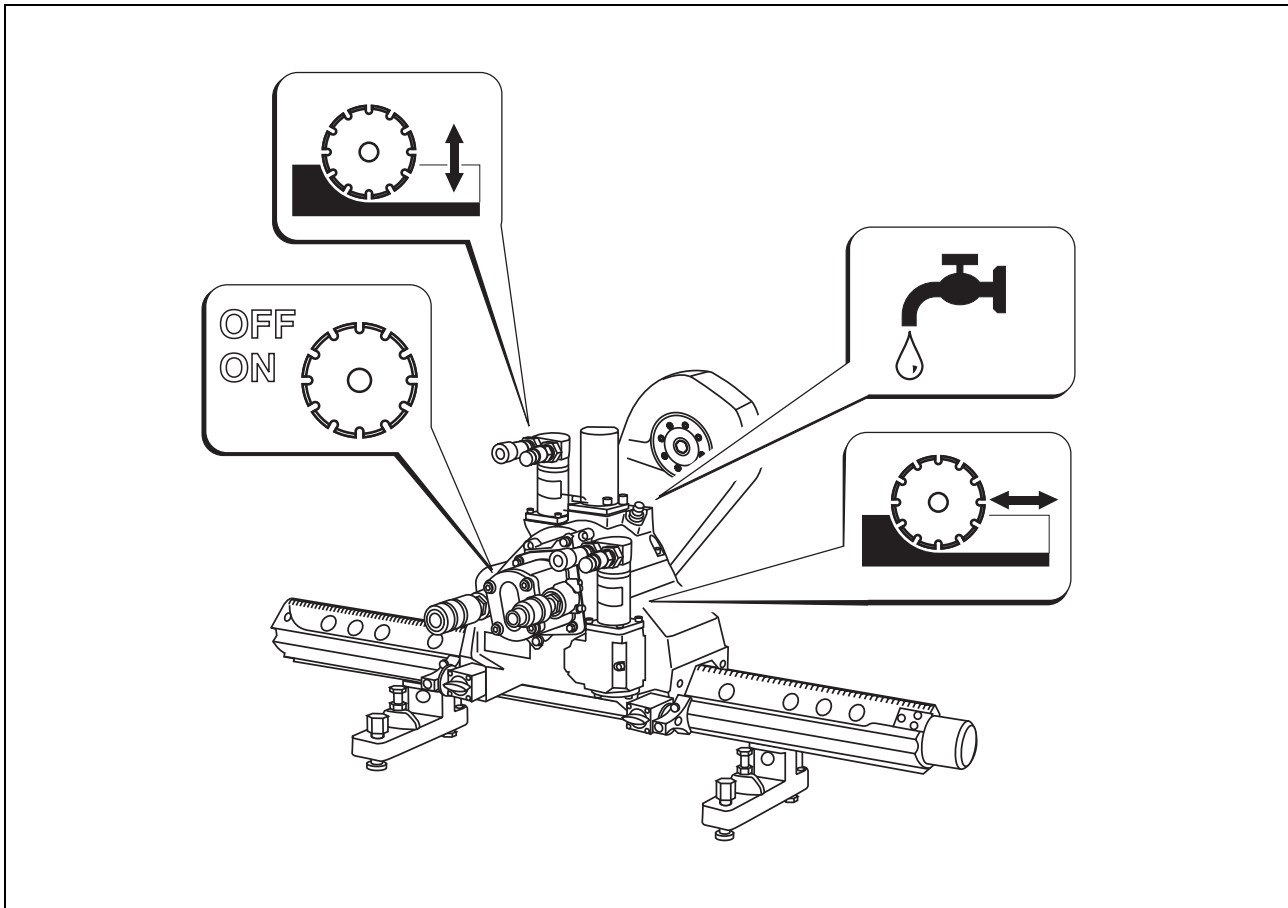

- 3 Swivelling motor
- 4 Belt wheel
- 5 Toothed belt cover
- 6 Toothed belt
- 7 Overload coupling
- 8 Swivel arm
- 9 Feed motor
- 10 V-rail
- 11 Clamping block
- 12 Dowel screw
- 13 V-rail support
- 14 Slide guide
- 15 Chassis
- 16 Saw motor

4.5 Function

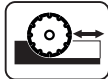
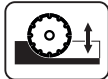

Function (table)

This.... by means of this drives this	Remarks
Saw blade drive 			
Main circuit	Hoses	Saw motor	Direction of rotation is set
Saw motor	Toothed belt	Saw blade	Ratio 1:2
Feed on rail 			
Feed circuit	Hoses	Feed motor	Set direction of feed and speed on the unit
Feed motor	Worm drive	Toothed wheel	Toothed wheel engages on rail
Swivelling of wall saw head 			
Swivel feed	Hoses	Swivelling motor	Set direction of swivel and speed on the unit
Swivelling motor	Worm drive	Swivel arm	360° swivel
Water 			
Drive unit	Hose	Coupling to saw head	Adjust water on unit
Coupling to saw head	Line to swivel arm	Swivel arm	Central water supply

4.6 Controls and connections

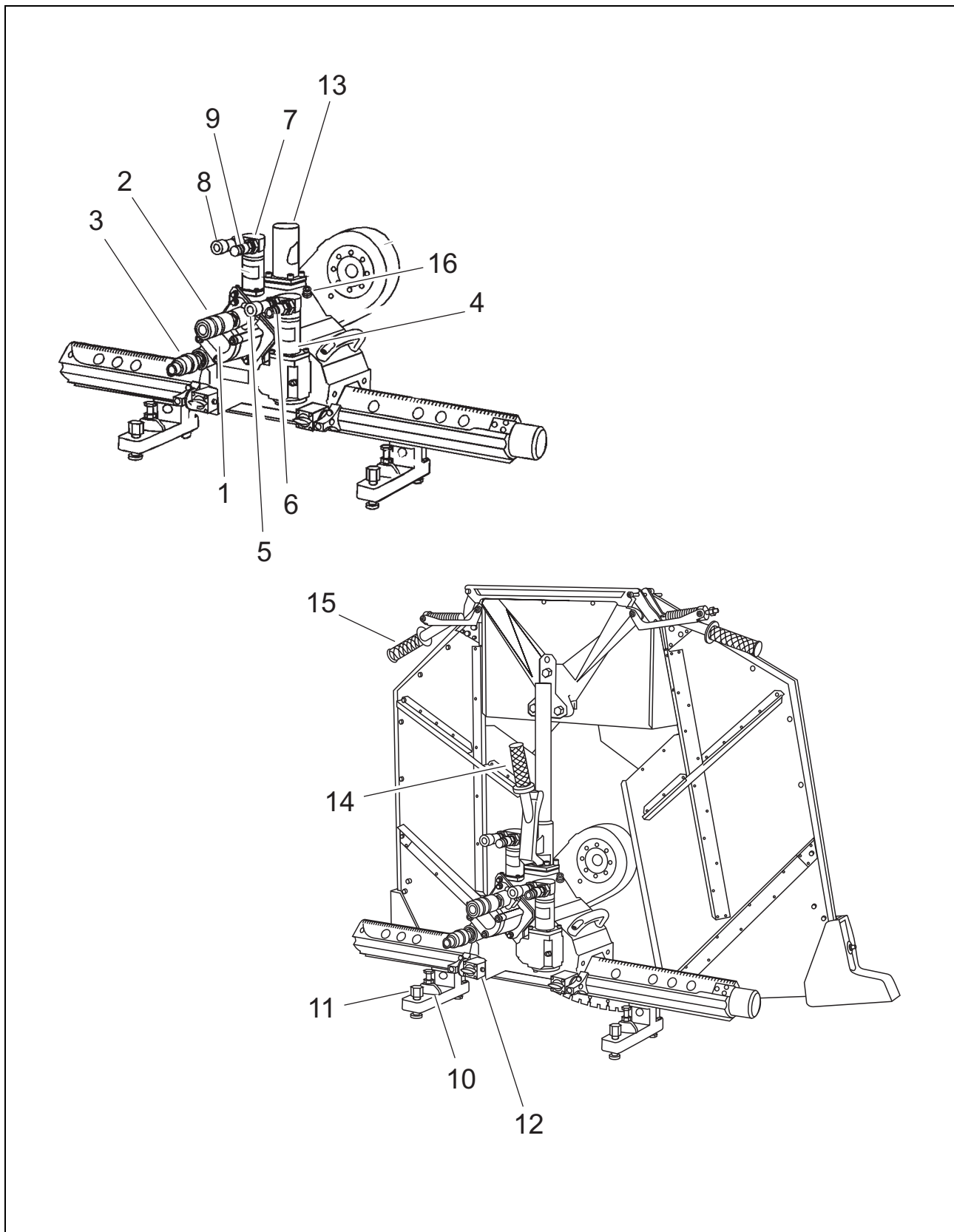

4.7 Function (table)

Pos. no.	Designation	Function
1	Saw motor	Saw blade drive
2	Saw motor coupling	Main circuit oil inlet
3	Saw motor nipple	Main circuit oil outlet
4	Feed motor (travel)	Drive (travelling motion)
5	Feed motor coupling	Feed circuit oil inlet or outlet (feed direction)
6	Feed motor nipple	Feed circuit oil inlet or outlet (feed direction)
7	Feed motor (swivel)	Drive (swivelling motion)
8	Feed motor coupling	Feed circuit oil inlet or outlet (swivel direction)
9	Feed motor nipple	Feed circuit oil inlet or outlet (swivel direction)
10	Clamping block with dowel screw	V-rail anchoring
11	Adjustment screws	Compensation for uneven floor
12	Feed grip	Adjustment of play between wall saw head and rail
13	Blade guard seat	Seat for blade guard
14	Clamping handle	Lock / release blade guard
15	Clamping handle	Lock / release side wing
16	Water connection	Water supply (cooling water)



Emergency stop

The wall sawing system can only be shut down on the drive unit. Follow the operating instructions of the unit you are using.

5 Set-up

5.1 Initial start-up

The wall sawing system is delivered ready for use. All instructions in this chapter are equally valid at the initial start-up.

5.2 Preparatory operations

Always proceed as follows:

- Sort out fundamental conditions
- Secure the site
- Decide on position and sequence of the cuts
- Select saw blade
- Carry out a visual inspection

Always pay detailed attention to the following before using the system:

Position of supply lines

- Determine the position of pipes and cables in walls and ceilings.

Water

Where does the cooling water used for sawing flow to?

- Think about water damage to the electrical supply.

Secure the site

- Secure the area where the wall sawing system will be used.
- Access by those not involved should be prevented.
- When cutting walls consider the other side of the wall.
- Secure this area as well.

Securing cutouts

- Secure cutouts from walls and especially from ceilings by suitable means, e.g. crane, supports, etc.
- Check the weight of concrete. (1m³= 2400-2700 kg)

Position of cuts

- Find out about the concrete to be sawed.
 - Where does the reinforcement run?
 - Is it heavily or lightly reinforced?
 - Is it suitable for steel plug fixing?
- Decide on the position and sequence of cuts before starting work. For example, for a door cutout carry out the bottom cut first, then the side cuts and finally the top cut.

Cut across the reinforcement if possible

The wrong sequence of cuts can lead to jamming of the blade or to damage to the equipment.

Rail length

- Determine the rail length for the intended cut.
- Leave sufficient projection for the wall saw head.

5.3 Selecting the saw blade

- Select the saw required blade diameter according to the requirements of the cut and the technical conditions.

Precut

A precut of dia. 800 mm is recommended for all work.

Anchoring options for saw blades

What saw blades are to be used?

External dia.: 450 -1200 mm
 Dia. location hole: 60 H7 mm

Normal cut

Anchoring
 Blade cover with central screw 977065

Flush cut

Anchoring
 Flush cutting flange 974419

What cutting depth do you want to achieve?

The “Cutting depth” table shows how big the saw blade must be according to the cutting depth.

Saw blade dia.	Cutting depth	Precut required?
800	30	No precut required
900	35	
1000	40	Precut with small blade required
1200	50	

Cutting depth example

Sawing an opening in a 35 cm thick concrete wall:

- The saw blade must be **900 mm** in size (see “Cutting depth” table).
- At the maximum plunging depth the saw blade will have a **30 cm overlap** at both ends of the cut (see “Overlap” table).

How big is the overlap?

The “Overlap” table shows by how much the saw blade overlaps at both ends of the cut,

according to the plunging depth and the size of the saw blade.

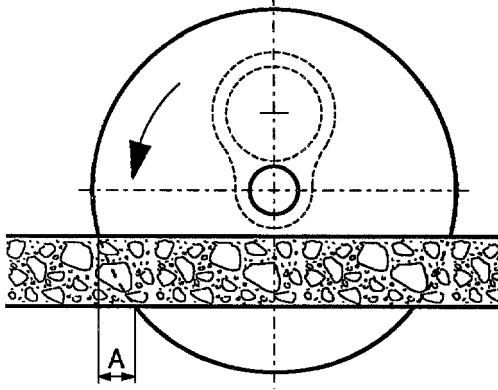
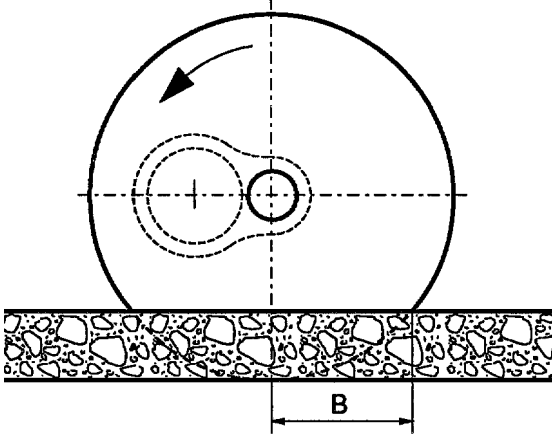
	Saw blade with max. plunge									Saw blade with min. plunge								
																		
	Size of saw blade									Size of saw blade								
Concrete thickness in cm	Dia. 500	Dia. 600	Dia. 750	Dia. 800	Dia. 900	Dia. 1000	Dia. 1200	Dia. 1500		Dia. 500	Dia. 600	Dia. 750	Dia. 800	Dia. 900	Dia. 1000	Dia. 1200	Dia. 1500	
5	2	2	2	2	1	1	1	1	15	15	18	18	20	21	21	21	27	
10	6	5	4	4	3	3	3	2	20	22	25	26	28	29	32	32	37	
15	14	10	7	7	5	5	4	3	23	25	29	31	32	35	39	45	45	
20	-	18	12	11	9	8	7	5	-	28	33	34	37	39	44	51	51	
25	-	-	19	17	13	12	10	7	-	-	35	36	43	43	49	56	56	
30	-	-	-	26	20	17	13	10	-	-	-	38	43	45	52	60	60	
35	-	-	-	-	30	24	18	13	-	-	-	-	44	47	54	64	64	
40	-	-	-	-	-	36	24	17	-	-	-	-	-	48	55	67	67	
45	-	-	-	-	-	-	31	22	-	-	-	-	-	-	57	69	69	
50	-	-	-	-	-	-	44	27	-	-	-	-	-	-	58	71	71	
55	-	-	-	-	-	-	-	34	-	-	-	-	-	-	-	73	73	
60	-	-	-	-	-	-	-	43	-	-	-	-	-	-	-	73	73	

5.4 Replacing saw motor

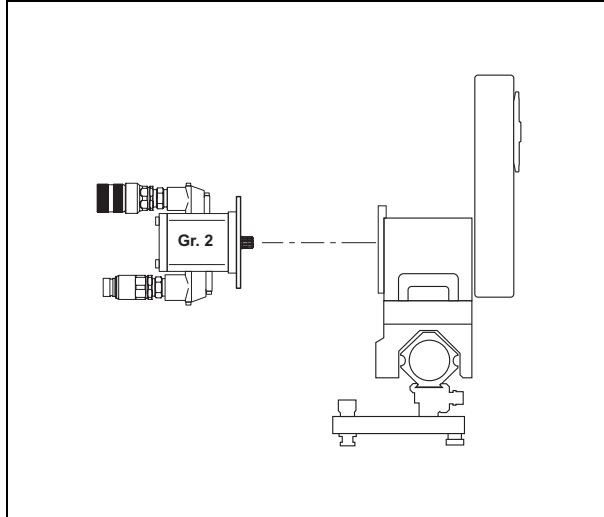

Mount saw motor (size2)

- Position saw motor with toothed profile coupling on the drive shaft and rotate
- Tighten M8 Allen screws

Connect hoses

- Push the hose coupling onto its counterpart until you hear it “click”
- Rotate the locking ring of the coupling



Ensure that the hydraulic hoses are properly coupled. Always rotate the locking ring following coupling.

Disassemble saw motor



Never connect or disconnect hoses when the drive unit is running.

- Switch off drive unit
- Reduce pressure (see drive unit operating instructions)
- Uncouple hoses from saw motor
 - Rotate locking ring
 - Hold hose straight
 - Slide back coupling sleeve
 - Pull off hose

Keep hose couplings clean and never allow them to drop.
Do not uncouple hoses at the drive unit side, so that pressure can be reduced via the drive unit.

- Loosen Allen screws.
- Rotate saw motor and remove.

5.5 Mounting V-rails on concrete

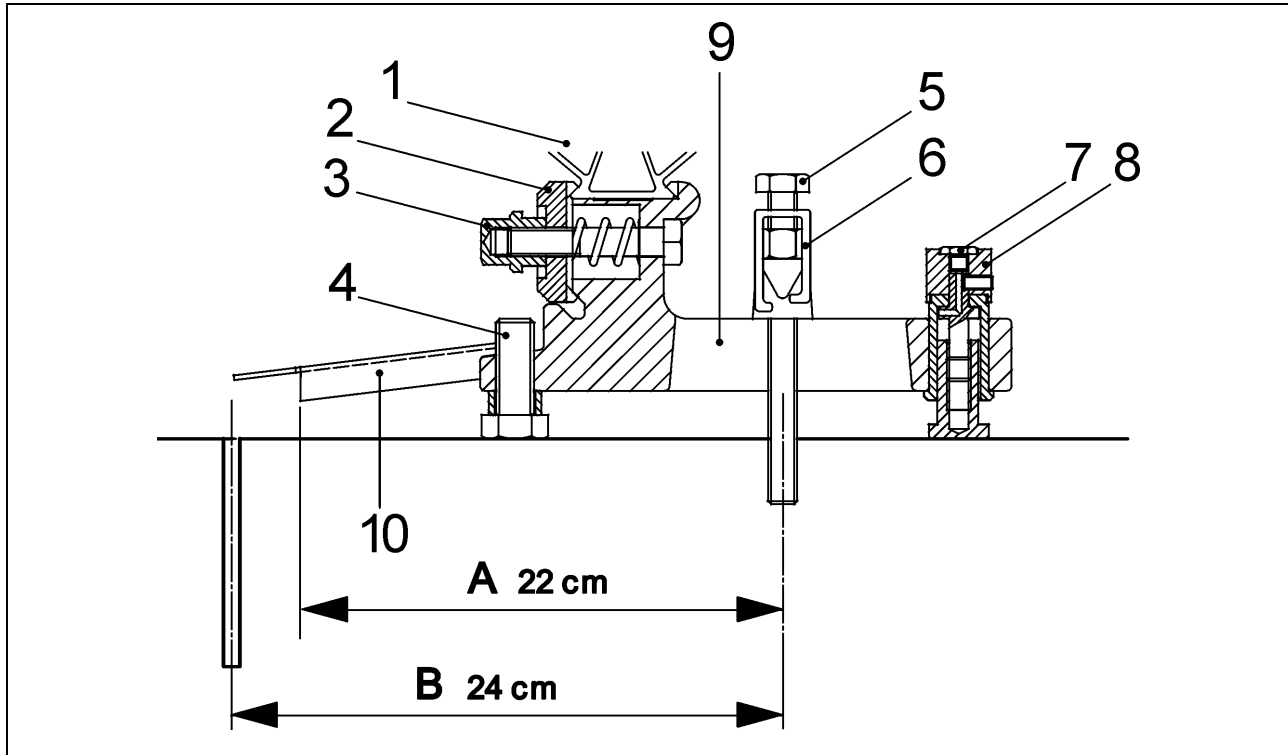

A Normal cut

B Flush cut

1. V-rail
2. Clamp
3. Adjusting nut
4. Adjusting screw
5. Dowel screw
6. Clamping block
7. Grease nipple
8. Adjusting foot
9. V-rail support
10. Cut guide



Please note the following:
Incorrect mounting of the rails
can endanger people during
sawing.

Use the following:

- for each dowel screw (5) the clamping blocks (6)
- steel plug: dia. 15 mm / M12
- screws (5): length = 130 mm
- **two** rail supports for the first V-rail, one rail support for each additional V-rail

Procedure

- Mark cutting line on the concrete.
- Mark dowel line at a distance of 22 cm.
(The same distance applies for flush cuts)
- Drill dowel hole and fit dowel according to dowel manufacturer's instructions
- Mount V-rail supports (9) on V-rails (1).

Clearance between rail supports:

- where a single rail is used, as high as possible
- where a number of rails are used, evenly distributed along the entire length of rail.

- Mount rail unit on concrete and align using cut guide (10)
- Align rail unit with adjusting foot (8), so that all adjusting feet (8) and the adjusting screws (4) are supported by the concrete.
- Tighten rail unit (1)



Once rail unit has been mounted check adjusting nut (3) and clamping block (6) anchoring



Steel rail support 974478 should not be combined with the VAS rails

Flat, aluminium V-rail support 965987 should be combined with VS-rails and VAS-rails.

Rail limit stop

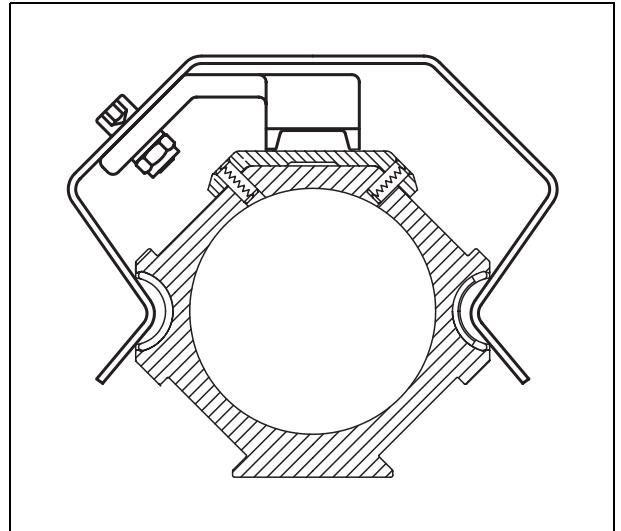

- Mount rail limit stop on the end of the rail, so that the wall saw head cannot fall off the rail.

5.6 Fitting wall saw head

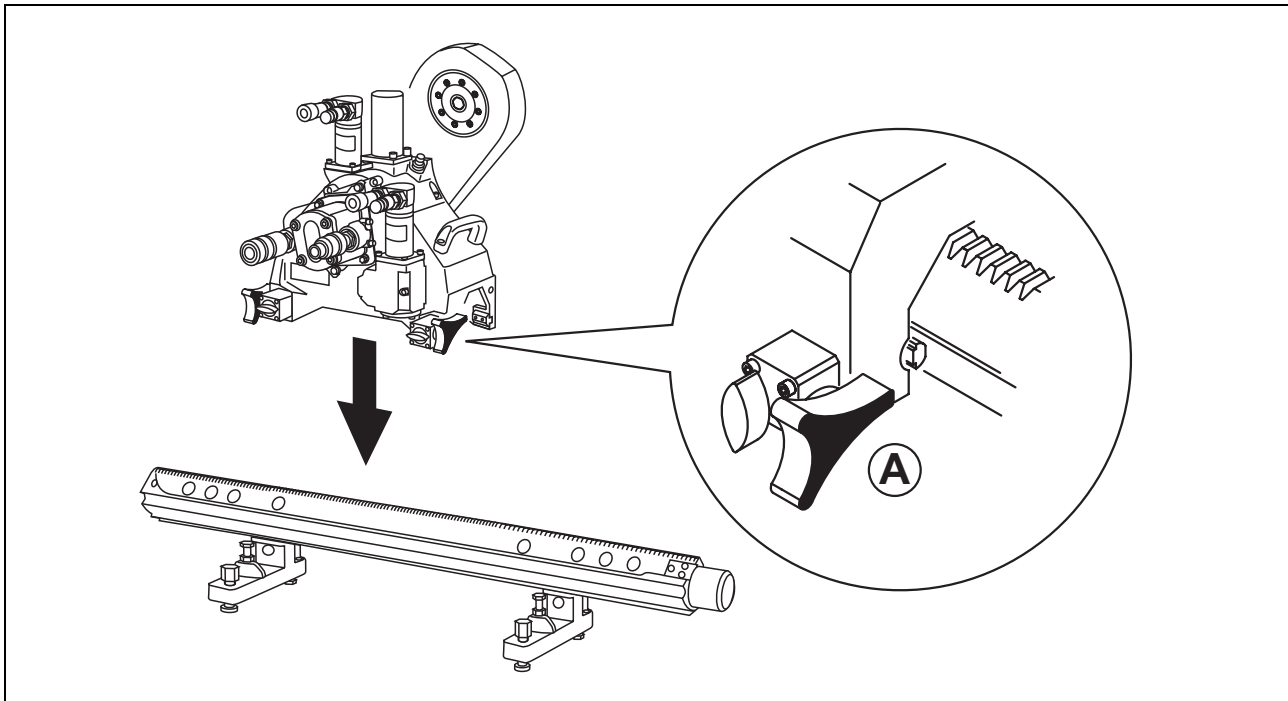

Procedure

Fit wall saw head **without** saw blade

Note position of Y-grips (A)

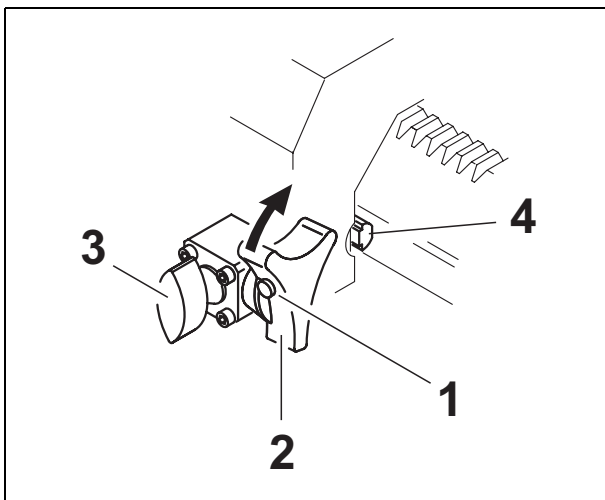

- 1. Twistlock
- 2. Y-grip
- 3. Feed grip
- 4. Guide prisms

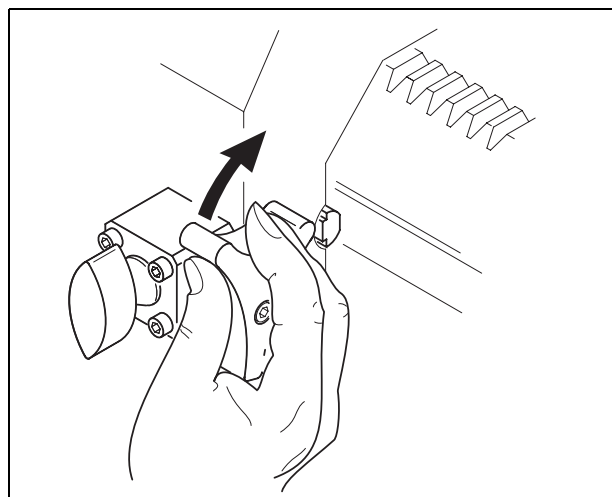

- Rotate Y-grip (2)
- Twistlock (1) latches

5.7 Adjustment / Taking up play

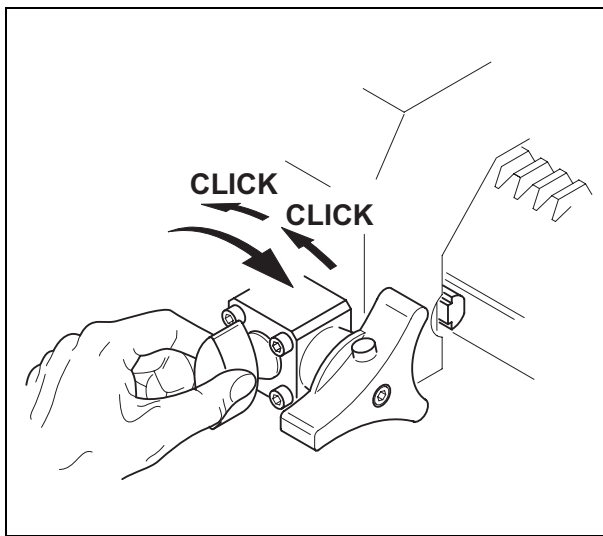

- Screw in feed grip (3) clockwise until the prism rests on the rail without any play
- Screw back by two latch positions

5.8 Removing the slide guides

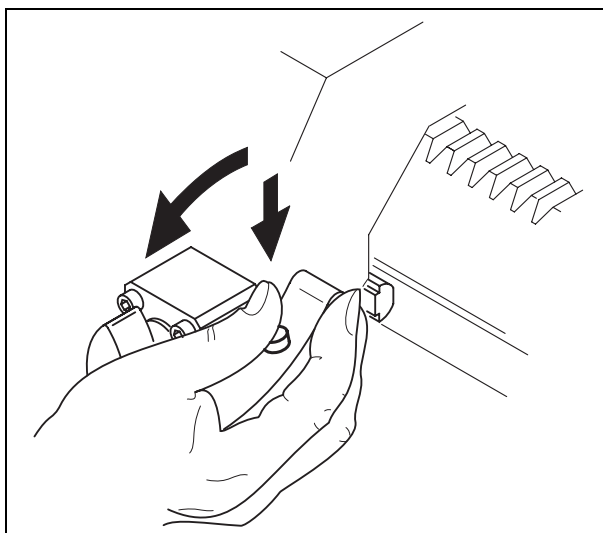

- Press on the twistlock (1) with your thumb whilst ...
- ... turning the Y-grip (2) anticlockwise

6 Anchoring saw blade for normal cutting



If the saw blade is not properly secured, it may come loose and cause serious injury. It is therefore essential to closely follow the instructions below.



If the drive unit is running or if the hoses are under pressure, a stationary saw blade can still suddenly rotate and seriously injure someone. It is therefore essential to closely follow the instructions below.

- Always switch off the drive unit and relieve the pressure in the hoses before handling the saw blade.

Assembly

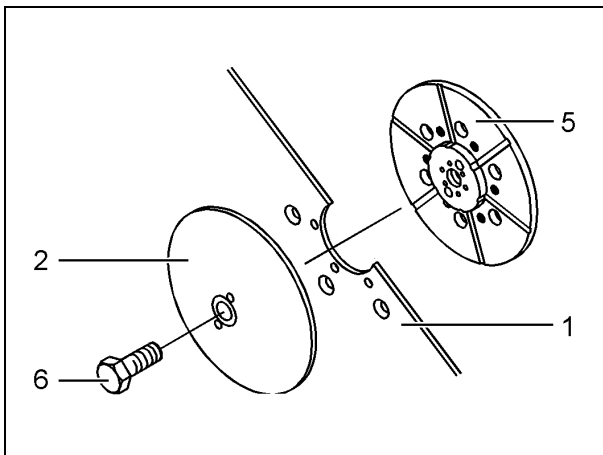

- Place saw blade (1) with a 60 dia. hole on the blade flange (5)
- Saw blade alignment:
Countersinkings against blade cover (2)
- Screw down the blade cover (2) with 1 hexagon head cap screw (6) onto the blade flange (5).



Use the following screws only:
Hexagon head cap screw M16x30,
order no. 971937

7 Anchoring saw blade for flush cutting



If the saw blade is not properly secured, it may come loose and cause serious injury. It is therefore essential to closely follow the instructions below.

- Always fasten the saw blade with all screws supplied and use only screws of the correct grade.



If the drive unit is running or if the hoses are under pressure, a stationary saw blade can still suddenly rotate and seriously injure someone. It is therefore essential to closely follow the instructions below.

- Always switch off the drive unit and relieve the pressure in the hoses before handling the saw blade.

- Place saw blade (1) with a 60 dia. hole on the flush cutting flange (2)
- Secure saw blade with countersunk head screws (3) onto blade flange (2).



Use the following screws only:
Countersunk head screw M8x16, 10.9 DIN 7991,
order no. 971825

Assembly

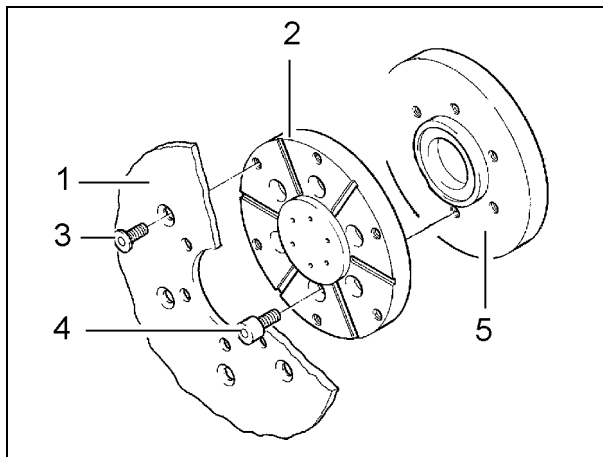

- Secure flush cutting flange (2) with 6 Allen screws (4) onto blade holder (5).



Use the following screws only:
Allen screws M8x16, 12.9 DIN 912,
order no. 971732

8 Connecting the drive units

Fundamentals



Never connect or disconnect hoses when the drive unit is running.



If the unit is running or if the hoses are under pressure, a stationary saw blade can still suddenly rotate and seriously injure someone. It is therefore essential to closely follow the instructions below.

- Clean the couplings regularly
- Always switch off the drive unit and relieve the pressure in the hoses before handling the wall saw
- If the hoses cannot be connected easily, they are under pressure (Release pressure in the hose)

Releasing pressure in the hose

1. **Hoses coupled to the drive unit**
(see drive unit operating instructions)
2. **Hoses that are not coupled**
Put the supplied pressure relief valve on the coupling and screw it in

Connect together both ends of any hoses, which are not used, so that they are kept clean and are protected.

Connect hoses

The following hose connections must be established:

Wall sawing system	Drive unit
Saw motor	Main circuit
Swivelling motor	Feed circuit
Feed motor	Feed circuit
Water connection	Water connection

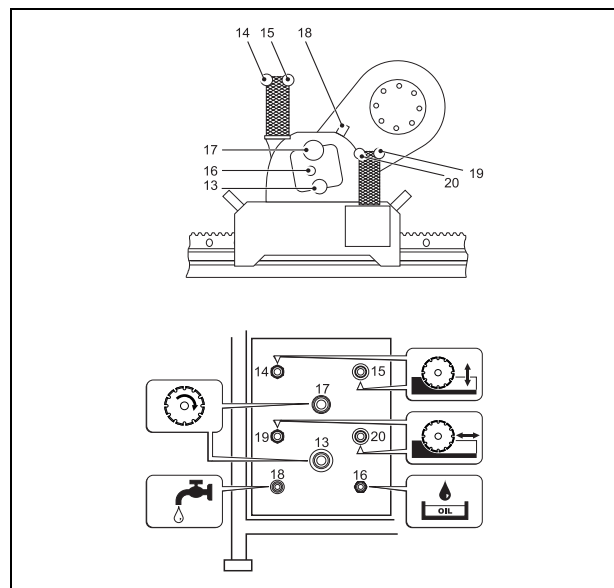

- Connect the hose couplings with the angle pieces to the wall saw head
- Connect the straight hose couplings to the drive unit
- Push the hose coupling onto its counterpart until you hear it “click”
- Twist the locking ring of the coupling

Never use force to connect the couplings

9 Sawing

9.1 Before sawing



Never saw without the blade guard.

Follow the instructions below:

- Check direction of travel and swivelling motion
- Teeth of rails must be clean
- Cut guides on rail supports must be folded in
- Cover sharp-edged objects
- Check that all dowel screws on the rail supports have been tightened
- Check that all rail supports are firmly secured to the rail
- Rail limit stops must be mounted
- Check if water is emerging at the point of rotation of the saw blade
- Test run:
Run the wall saw head along the entire length of the rail and check that the hoses do not catch at any point

9.2 The first cut (precut)

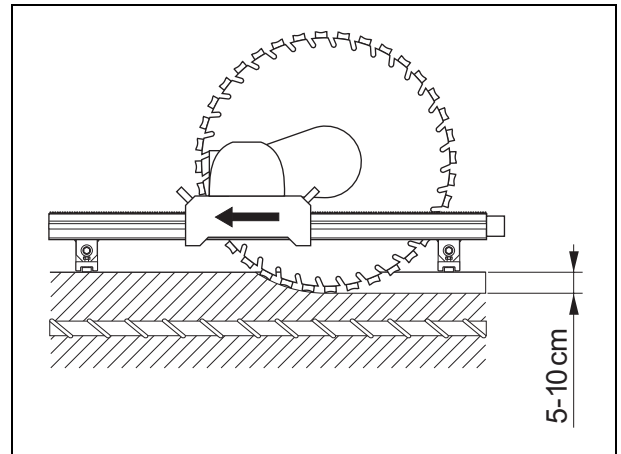

Procedure

Note:

- if possible do not cut through any reinforcements
- swivel arm pulled
- cutting depth 5-10 cm
- working pressure 100-120 bar

- Move wall saw head to starting position
- Sawing

9.3 After the first cut

Feed after the first cut

After the first cut more than 5-10 cm can be fed. The possible cutting depth is dependent upon the amount of reinforcement and the aggregates in the concrete and the size and specification of the blade.

The optimum cutting depth can be between 7 and 12 cm.

Cutting through reinforcements

For cuts following the length of the reinforcement:

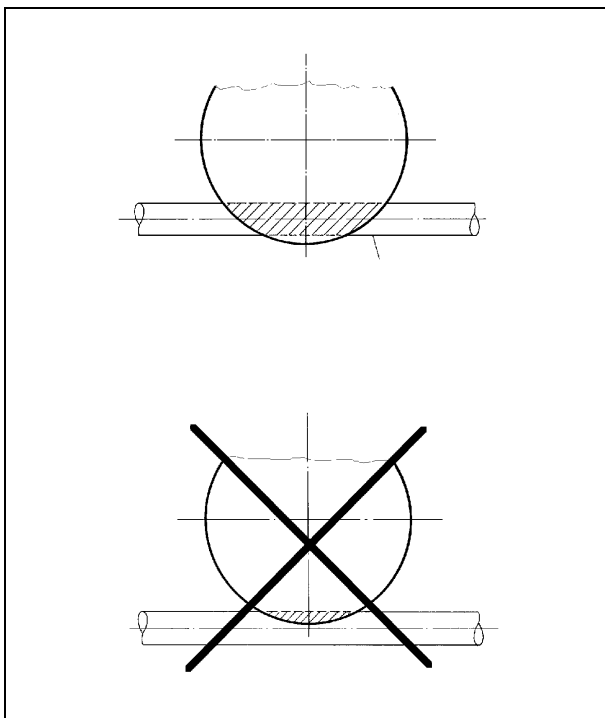

- Prepare the cut so that the reinforcement is completely cut through.
- Do not plan the cut along the reinforcement. The cut would otherwise drift.

In sections where there are no reinforcing rods do not use high power cutting, but reduce this by about 40 bars. If the blade touches any reinforcing rods, the pressure will not then increase above the maximum permitted level.

Always withdraw from a cut with the saw blade running.

If the saw blade jams

- Carefully withdraw from the cut with a travelling or swivelling motion.
- If this does not work: Disassemble saw blade from wall saw head and remove saw blade alone from the cut.

At the end of the cut

- Withdraw from the cut with the saw blade running
- Move swivel arm to the uppermost position

9.4 Terminating the work



Always switch off the drive unit and relieve the pressure in the hoses before handling the wall saw

- Clean wall sawing system, e.g. by spraying with water

Uncoupling hoses

- Switch off drive unit and relieve the pressure in the hoses
- Rotate locking ring to release position
- Hold hose end straight
- Slide back coupling sleeve
- Pull off hose
- Couple hoses together to avoid soiling and damage

10 Troubleshooting

Proceed systematically when looking for the cause of a fault. In doing so also refer to the operating instructions for the electric motor and control unit(s).

If you cannot find the defect or eliminate the faulty condition, please contact our after-sales service.

Before calling us, please note the following:

- The more accurately you describe the fault, the better we can help you.
- Have the operating instructions close to hand.
- Note down the serial number of your equipment.

Fault	Possible cause	Solution
Wall saw head does not move or only moves jerkily on the rail	Slide guide tightened too hard	Loosen slide guide slightly so that slide (without sawing) starts to move at 20 bar
	Rail toothing soiled	Clean rail
	Prisms worn	Exchange prisms
	Guiding groove of rail warped	Replace rail
	Misaligned rail joint	Use rail lock
	Wrong or defective feed motor	Exchange motor
	Defective feed gears	Exchange feed gears, contact HYDROSTRESS after sales service
	Hoses incorrectly coupled	See "Coupling hoses"
	Defective drive unit	Check drive unit
Swivel arm does not move or only moves jerkily	Wrong or defective feed motor	Exchange motor
	Defective swivel gears	Exchange swivel gears, contact HYDROSTRESS after sales service
	Hoses incorrectly coupled	See "Coupling hoses"
	Defective drive unit	Check drive unit
Main pressure fluctuates wildly	Speed too low	Mount correct saw motor according to motor table
	Saw motor worn out	Exchange motor
Main pressure fluctuates wildly	Defective drive unit	Check drive unit
	Wrong or defective feed motor	Exchange motor

Fault	Possible cause	Solution
Blade does not rotate when main circuit is switched on	Saw blade jams	Lift saw blade from cut slightly
	Defective drive unit	Check drive unit
	Incorrectly coupled	Check couplings
	Defective drive belts	Exchange drive belts, contact HYDROSTRESS after sales service
Saw motor heavily fouled by oil	Defective saw motor shaft sealing ring	Exchange shaft sealing ring
	Leaky seals or couplings (FD)	Exchange seals or couplings, contact HYDROSTRESS after sales service
Coupling leaks	Defective seal	Replace seal
	Defective coupling	Replace coupling
No water on saw blade	Water valve shut off	Open water valve
	Water hose incorrectly coupled	Couple water hose, locking ring must slide forwards
	Water pressure too low	Water pressure: min. 1 bar
	Water supply interrupted	Check the water supply
	Pipes frozen	Thaw pipes, contact HYDROSTRESS after sales service
	Defective seal between shaft and blade hub	Exchange seal, contact HYDROSTRESS after sales service
Sawing power is inadequate, despite correctly selected saw motor	Defective saw motor	Replace saw motor
	Defective feed motor	Replace feed motor
	Defective drive unit	Check drive unit
	Incorrect saw blade	Contact HYDROSTRESS after sales service
	Incorrect segments	Segments too hard, use softer segments
	Cutting untrue	Tension saw blade
	Cutting speed too high	In the case of hard aggregates or a lot of reinforcements, reduce the speed
	Saw blade polished	Sharpen saw blade with a grindstone

11 Maintenance

11.1 Maintenance table

Service the system within the indicated intervals in order to ensure:

- Safety for the operator
- Optimum performance
- Optimum reliability at all times



Uncouple wall sawing system prior to performing maintenance work on the unit

Maintenance interval	Action	Remarks
weekly	Check prism guides for wear	Replace, before anchoring screws of prisms touch the rail or the wall saw chassis touches the rail
weekly	Check couplings for <ul style="list-style-type: none"> - leaks - damage 	Replace leaky or damaged couplings
weekly	Grease Y-slide guides grease nipple	2-3 grease injections
weekly	Check water couplings for <ul style="list-style-type: none"> - leaks - damage 	Replace leaky or damaged couplings
annually	Change bearing housing grease	Fill with 600 g gear grease (Page 34)
annually	Major service	Must only be performed by HYDROSTRESS or a HYDROSTRESS authorised representative

Correct maintenance procedures are described on the following pages.

11.2 Change prism guides

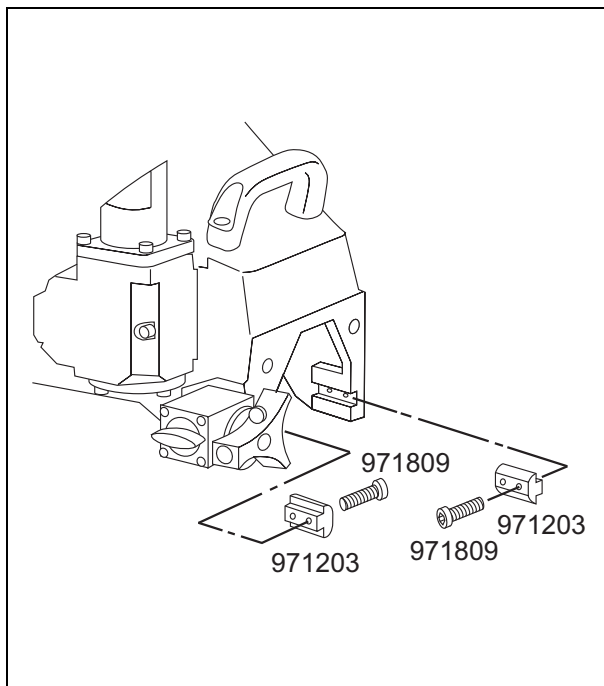

11.4 Exchange swivelling motor

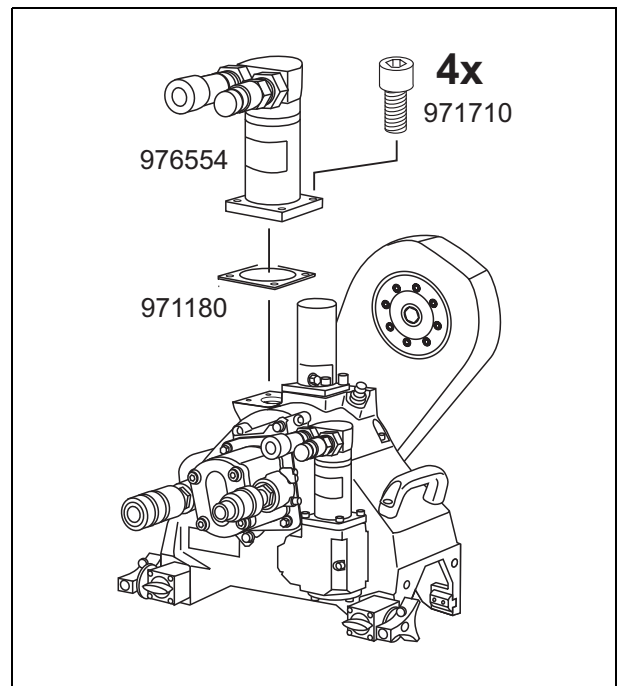

Use the following screws only:
Cylindrical screw M6x20, grade 12.9, order no. 971710

11.3 Change feed motor

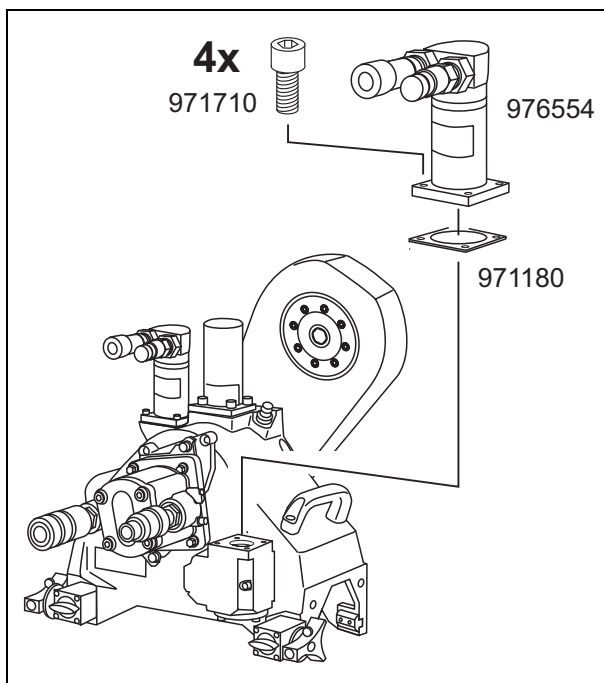

Use the following screws only:
Cylindrical screw M6x20, grade 12.9, order no. 971710

11.5 Change gear grease

Use only grease with penetration rate 420-460 NLGI code: 00.

Feed gears

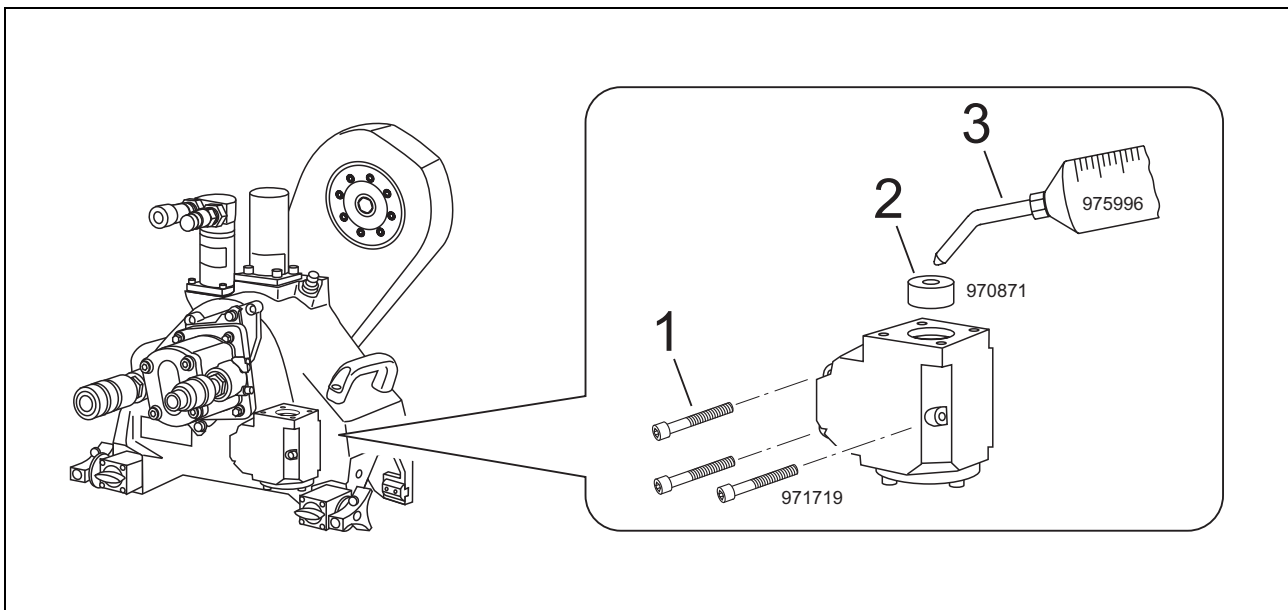

- Disassemble feed motor
- Disassemble feed gears
Remove 3 Allen screws (1) M6x55 / 971719
- Fit support foot (2) 970871
- Fill with 100 g grease using grease gun (3) 975996
(old grease is forced out by the new grease)
- Mount feed gears
- Mount feed motor with paper seal

Bearing housing

- Remove blade guard seat
- Stand wall saw on its head
- Empty out old gear grease
- Fill with 600 g gear grease via the opening in the blade guard quick acting closure
- Fully remount blade guard seat.

11.6 Toothed belt tensioning

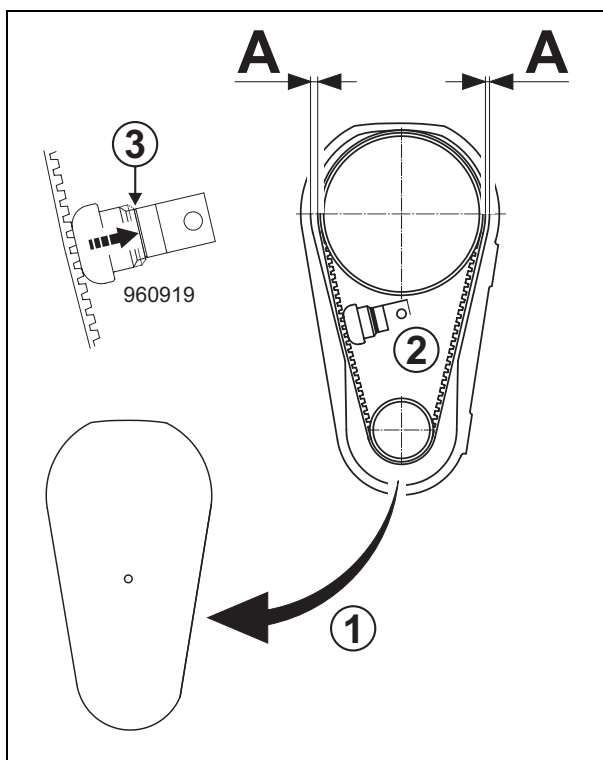

- Disassemble the protective cover (1)
- Fit toothed belt tension checker 960920 (2)
- Carry out measurement on side with the greatest clearance (A)
- Check toothed belt tension with tension checker 960920 (3)

11.7 Tensioning the toothed belt

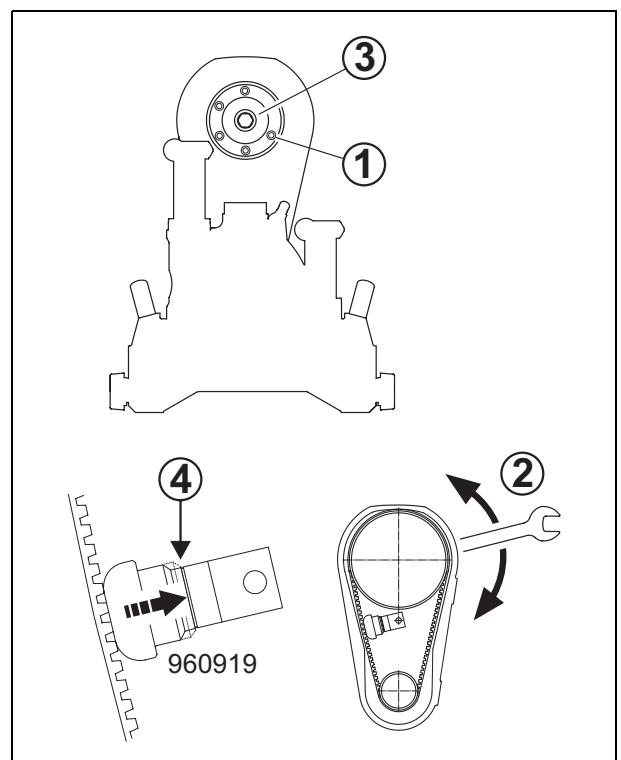

- Disassemble protective cover
- Fit toothed belt tension checker 960920
- Loosen all 6 screws (1)
- Use ring spanner SW 36 (2) to turn screw (3) until toothed belt tension is correct
- Tighten all 6 screws (1)
- Check tension with tension checker (marking DZ-S)
- Remove toothed belt tension checker 960920
- Mount protective cover

11.8 Exchanging toothed belt

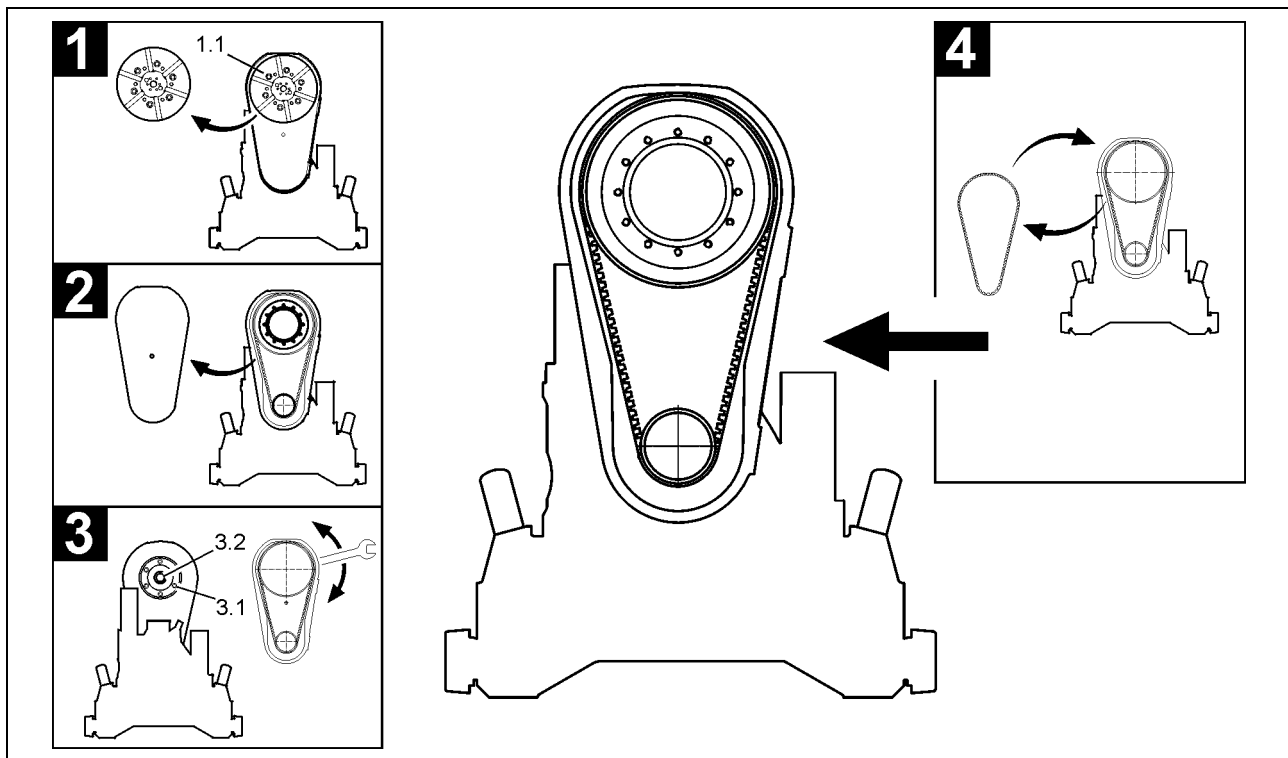

- Disassemble blade hub (1)
 - Loosen all 6 screws 1.1
- Disassemble the protective cover (2)
- Relax toothed belt (3)
 - Loosen all 8 screws 3.1
 - Loosen screw 3.2 with open ended spanner
- Replace toothed belt (4)
- Tension toothed belt 977273
(Page 35)
- Check toothed belt tension
(Page 35)
- Mount protective cover
- Mount blade hub

11.9 Repair

Components other than those described may only be replaced by authorized personnel trained at HYDROSTRESS.

12 Transport, taking out of service, storage, disposal

12.1 Transport

The wall sawing system is a high-tech product. Protect it against transport damage:

- Disassemble blade guard
- Do not place any parts against or on the wall sawing system, the blade guard or the rail system
- Protect the tothing of the rail system from impacts



Handle the wall sawing system with care and if possible using two people, in order to avoid back injuries and accidents.

12.2 Taking out of service and storage

The wall sawing system consists partially of material that can corrode. If you take the unit out of service for some time do the following:

- Blow the water out of the water line
- Coat the rail system with oil
- Store in a dry location

12.3 Disposal

The wall sawing system comprises the following materials:

- Aluminium casting
- Rolled aluminium products
- Bronze
- Steel
- Rubber
- Rubber / nylon fabric
- Synthetic lubricant
- Plexiglass
- Oil

Acquaint yourself with the local regulations for disposal in your country.

13 Accessories

13.1 Accessories available to order

V-rails VAS 1100mm alu	984536
V-rails VAS 1375mm alu	984719
V-rails VAS 1650mm alu	984720
V-rails VAS 1925mm alu	984546
V-rails VAS 2200mm alu	984537
V-rails VAS 1100mm steel	974400
V-rails VAS 1400mm steel	974402
V-rails VAS 1800mm steel	974404
V-rails VAS 2200mm steel	974406
Limit stop complete for rail VAS	963698
V-rail support steel	974478
V-rail support alu	965987
V-stair rail support	974487
V-swivel rail support	961983
Rail connector	977523
Blade guard 3-part 800mm alu	999180
Blade guard 3-part 800mm alu flush	999212
Blade guard 3-part 1000mm alu	984240
Blade guard 3-part 1000mm alu flush	999160
Blade guard 3-part 1200mm alu	962755
Blade guard 3-part 1200mm alu flush	999156
Toothed belt	969460
Pressure relief device FD	977495
Dowel gauge	977609
Dowel HKD M12	971622
Dowel drill dia. 15mm	977180
Dowel iron HKD M12	977153
Anchoring block for concrete	974476
Blade spacing ring 28mm	971298
Grease gun	975996
Support foot	970871
Flush flange	974419
Blade cover central anchoring	977065
Saw blade cover	961280
Belt tension checker DZ	960919
Tool box	975803

13.2 Hydraulic drive motors

Hydraulic drive motor size 2 (excluding quick change set)

Saw motors 12ccm / FD	976034
Saw motors 16ccm / FD	976160
Saw motors 18ccm / FD	976161
Saw motors 22ccm / FD	976162
Saw motors 26ccm / FD	976523
Saw motors 30ccm / FD	976163
Quick change set	973892

Hydraulic feed motor

Feed motor	976164
------------	--------

14 Spare parts list

14.1 Ordering information

For spare part orders we need the following information:

- Machine type and index according to type plate
(e.g. DZ-S2, Index 000)
- Number of machine according to type plate
(e.g. 51886)
- Spare part number as per spare parts list
(e.g. 08W7-75648-02)

For orders, enquiries and information, please refer to your appropriate branch office.

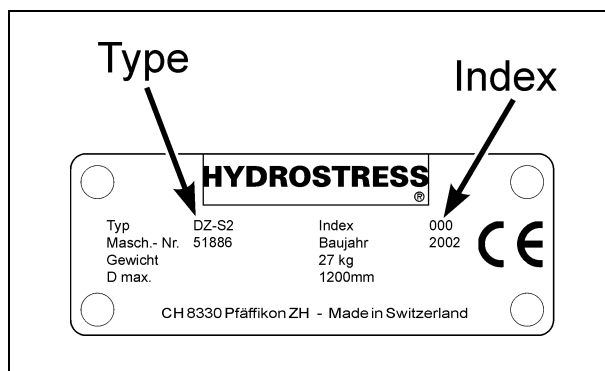

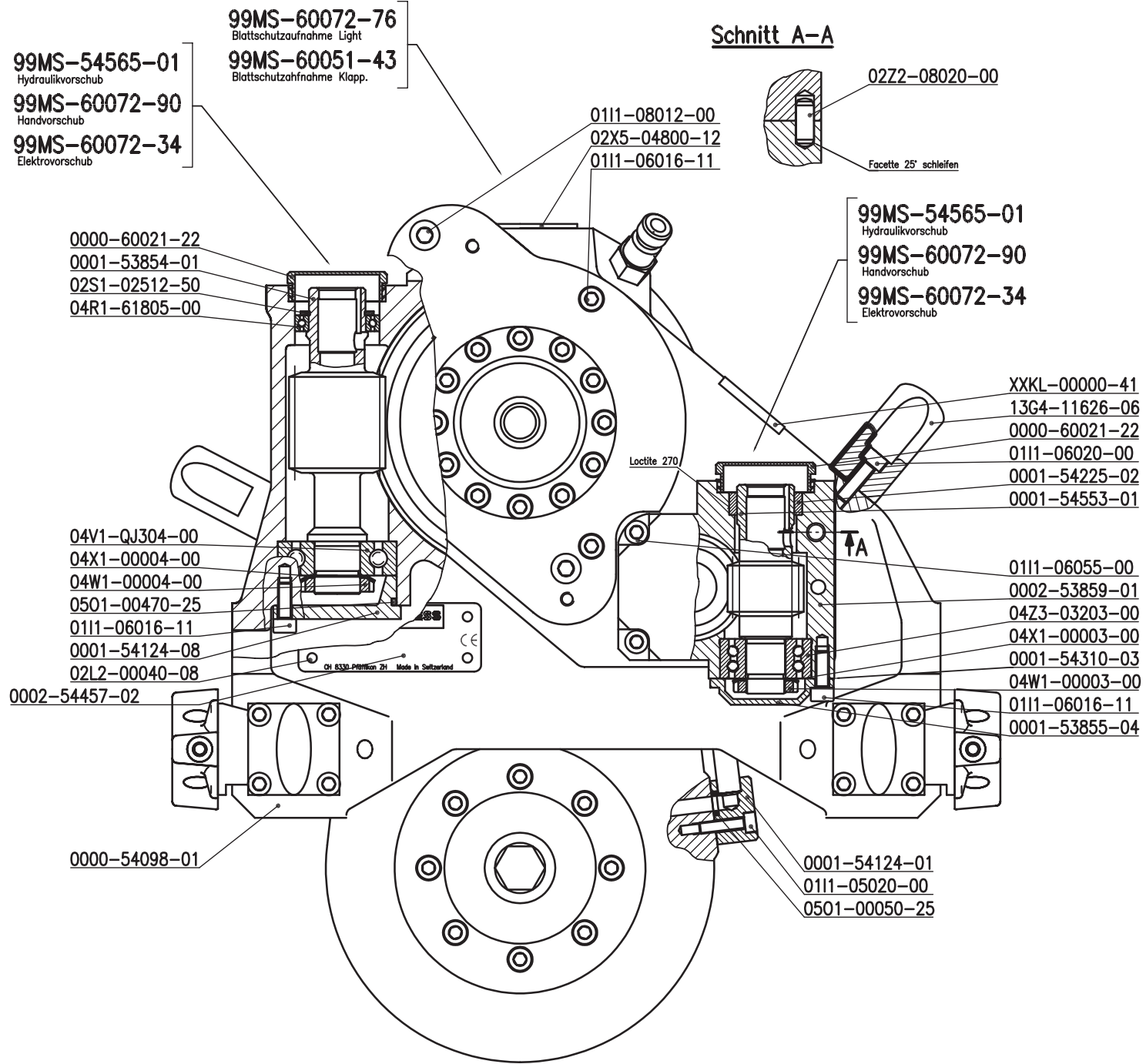

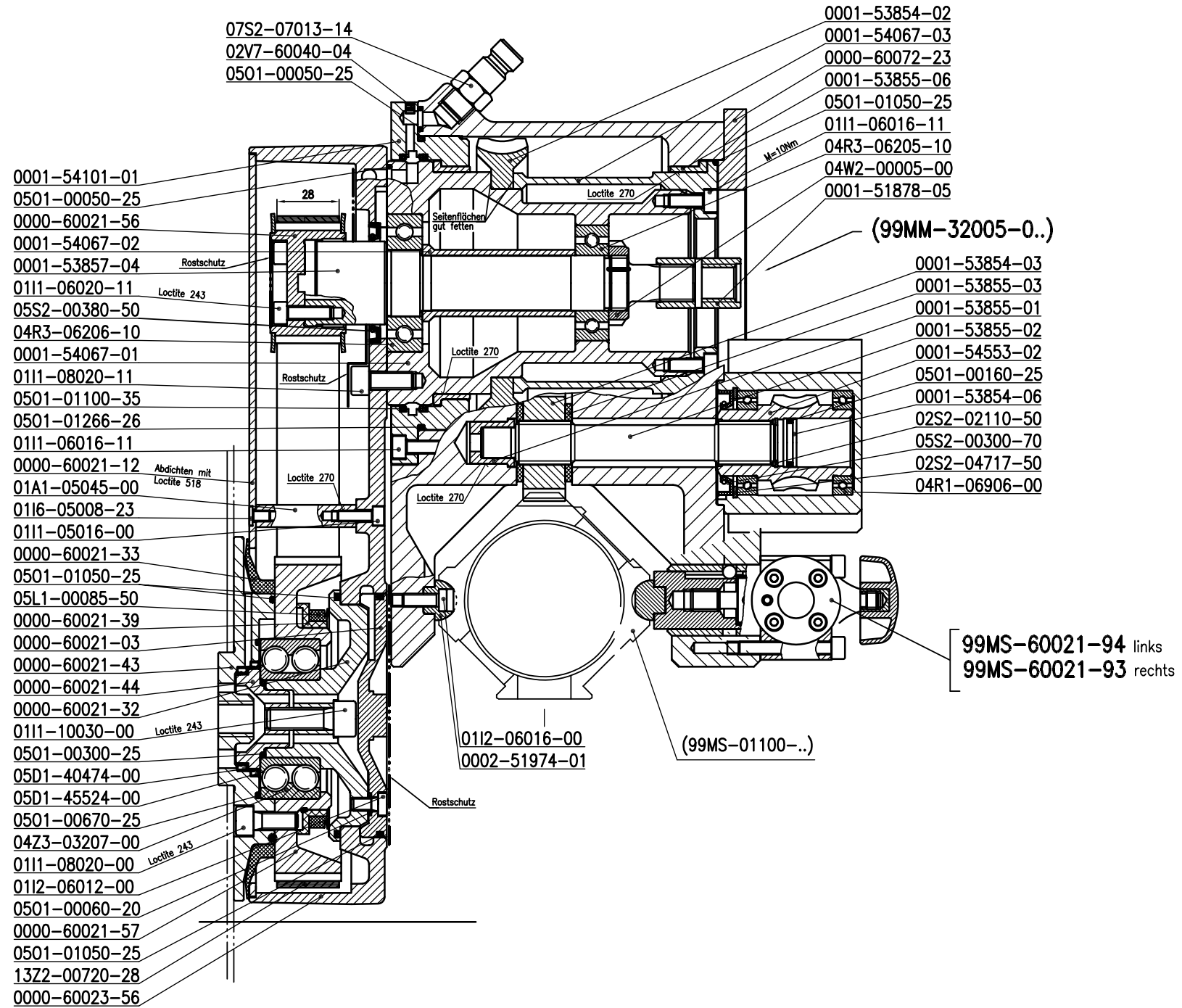

99MS-60023-55	999997	WANDSÄGE DZ-S2	WANDSÄGE DZ-S2	WANDSÄGE DZ-S2	WANDSÄGE DZ-S2	1
20HS-AZ006	973892	Schnellwechselsatz FZ/DZ/AZ	Quick-change set FZ/DZ/AZ	Plaque changement rapide	KIT CAMBIO RAPIDO MOTORE	1
99MS-60021-93	963548	Y-Schlittenf. R Bronze	Y-track guide right	Y-Schlittenf. R Bronze	Y-Schlittenf. R Bronze	1
99MS-60021-94	963547	Y-Schlittenf. L Bronze	Y-track guide left	Y-Schlittenf. L Bronze	Y-Schlittenf. L Bronze	1
99MS-54565-01	976554	Vorschubmotor DZ/FZ	Feed motor hydr.DZ/FZ	Moteur d'avance DZ/FZ	MOTORE AVANZ.PICC. 32 oml	2
99MS-60051-43	968764	Blattschutzaufnahme	Bolt	Blattschutzaufn.	Blattschutzaufn.	1
99MS-54653-01	976997	Vorschubgetr.1:16 DZ/FZ	Feed drive 1:16 DZ/FZ	REDUCTEUR AVANCE 1:16 DZ/FZ	RIDUTTORE AVANZ.1:16 DZ/FZ	1
0000-54098-01	970162	Support DZ	Support DZ	Support DZ	CHASSIS DZ	1
0000-60021-03	976356	Spannscheibe FZ	Face plate DZ/FZ	COUVERCLE DE SERRAGE FZ	DISCO DI TENSIONE FZ-FZ/S	1
0000-60021-12	977603	Schutzdeckel DZ-2/DZ-S	Cover DZ-2/DZ-S	Couvercle DZ-2/DZ-S	COPERCHIO CINGHIA DZ/2	1
0000-60021-22	968575	Schutzstopfen	Seal plug, reworking	Schutzstopfen Nacharbeit	Schutzstopfen Nacharbeit	2
0000-60021-32	976695	Lagerbolzen DZ-2 / DZ-S	Bearing bush DZ-2 / DZ-S	COUSSINET DZ-2 / DZ-S	ECCENTRICO DZ/2	1
0000-60021-33	976674	Dichtring DZ-2	Sealing ring DZ-2/DZ-S	JOINT DZ	ANELLO TENUTA ACQUA DZ	1
0000-60021-37	976677	Sägeblattdeckel DZ-2	outerflange DZ-2	FLASQUE D'APPUI	Sägeblattdeckel DZ-2	1
0000-60021-39	969108	Ring	Ring	Anneau	ANELLO PVC DZ/S	1
0000-60021-43	969106	Blattnabe DZ	Blade hub DZ	Moyeu DZ	MOZZO FLANGIA DZ/S	1
0000-60021-44	969107	Spannhülse	Tensioning bush	Douille de serrage	FLANGETTA MOZZO DZ/S	1
0000-60021-56	961500	Triebzahn z27 / B28	Triebzahn z27 / B28	Triebzahn z27 / B28	ORONA DENT. DZ-S (1:2) P	1
0000-60021-57	961501	Riemenzahn z54 / B28	Riemenzahn z54 / B28	Riemenzahn z54 / B28	CORONA DENT. DZ-S (1:2) G	1
0000-60021-68	977717	Exzenterwelle (Raster)	ECentricshaft (Raster)	Arbre excentrique	ALBERO A TACCHE X GUIDA	1
0000-60021-68	977717	Exzenterwelle (Raster)	ECentricshaft (Raster)	Arbre excentrique	ALBERO A TACCHE X GUIDA	1
0000-60021-69	977718	Prismenschieber (Raster)	Prism slide (grid)	Vanne prismatique	CURSORE A TACCHE GUIDA	1
0000-60021-69	977718	Prismenschieber (Raster)	Prism slide (grid)	Vanne prismatique	CURSORE A TACCHE GUIDA	1
0000-60021-71	977719	Druckplatte	pressure Plate	Cale de répart. de pressi	PIASTRA DI PRESS. PER GUI	1
0000-60021-71	977719	Druckplatte	pressure Plate	Cale de répart. de pressi	PIASTRA DI PRESS. PER GUI	1
0000-60021-72	977720	Exzenter	Excentre disc	Excentre disque	ECCENTRICO GUIDA	1
0000-60021-72	977720	Exzenter	Excentre disc	Excentre disque	ECCENTRICO GUIDA	1
0000-60021-76	977724	Gehäuse	Housing	Carter	SCATOLA GUIDA	1
0000-60021-76	977724	Gehäuse	Housing	Carter	SCATOLA GUIDA	1
0000-60021-77	977725	Rasterplatte	Latch plate	Plaque moteur	PIASTRA A TACCHE	1
0000-60021-77	977725	Rasterplatte	Latch plate	Plaque moteur	PIASTRA A TACCHE	1
0000-60021-78	977726	Griff rechts	grip right	Poignée droite	MANIGLIA GUIDA DX	1
0000-60021-79	977727	Rastbolzen	Latchbolt	Axe d'arrêt	PULSANTINO GUIDA	1
0000-60021-79	977727	Rastbolzen	Latchbolt	Axe d'arrêt	PULSANTINO GUIDA	1
0000-60021-86	977732	Griff links	grip left	Poignée gauche	MANIGLIA GUIDA SX	1
0000-60023-56	999998	Schwenkarm DZ-S2	Schwenkarm DZ-S2	Schwenkarm DZ-S2	Schwenkarm DZ-S2	1
0000-60059-09	977609	Dübellehre	Rawlplug template	Gabarit de tamponnage	Dübellehre	1
0000-60072-23	977400	Rasterplatte	Latch plate	Plaque moteur	PIASTRA COLL.RAP.MOTORE E	1
0001-51878-05	970394	Zahnprofil-Kuppl. AZ/DZ	Tooth profile coupling AZ	ACCOUPLLEMENT DENTE AZ	GIUNTO A PROFILO DENT. AZ	1

99MS-60023-55	999997	WANDSÄGE DZ-S2	WANDSÄGE DZ-S2	WANDSÄGE DZ-S2	WANDSÄGE DZ-S2	11
0001-53423-07	970963	Blinddeckel Sägeblattdeck	Blindcover, sawblade	DISQUE D'OPTURATION FLASQ	COPERCHIO FLANGIA	1
0001-53655-04	961278	Sägeblattdeckel Dm 164	Sägeblattdeckel Dm 164	Sägeblattdeckel Dm 164	Sägeblattdeckel Dm 164	1
0001-53854-01	971064	Schnecke SV	Worm SV	VIS SANS FIN SV DZ	VITE SENZA FINE BRAC. DZ/	1
0001-53854-02	971065	Schneckenrad SV	Worm SV	ROUE DE VIS SANS FIN SV D	RUOTA ELICOID. INTERNA DZ	1
0001-53854-03	974755	Vorschubrad	Feed wheel	PIGNON D'AVANCE DZ	RUOTA DENTATA AVANZ. DZ	1
0001-53854-06	971066	Dichtungsscheibe	Sealing washer	Joint	COPERCHIO TENUTA DZ/FZ	1
0001-53855-01	974757	Lagerhülse DZ/FZ	Storage sleeve DZ/FZ	Douille DZ/FZ	BUSSOLA ALBERO AVANZ DZ/F	1
0001-53855-02	971069	Vorschubwelle DZ/FZ	Feeding shaft DZ	Arbre d'avance DZ/FZ	ALBERINO AVANZ. DZ	1
0001-53855-03	971070	Lauftring DZ/FZ	Ring DZ/FZ	Anneau DZ/FZ	ANELLO TEFLON ALBER. DZ/F	2
0001-53855-04	971068	Lagerdeckel DZ/FZ	Sleeve DZ/FZ	COUVERCLE DE ROULEMENT DZ	COPERCHIO BLOCCO AVANZ. D	1
0001-53855-06	971071	Lagerbüchse DZ/FZ	Bearing bush DZ/FZ	Coussinet DZ/FZ	BOSSOLO PER SUPP. DZ/FZ	2
0001-53857-04	971076	Antriebswelle DZ/FZ	Pinion shaft DZ/FZ	ARBRE PIGNON DZ/FZ	ALBERO MOTORE DZ/DZ-2	1
0001-54067-01	974771	Lagerhülse DZ/FZ	Bushing DZ/FZ	ENTRETOISE DZ	MANICOTTO DZ FZ	1
0001-54067-02	974772	Distanzrohr DZ/FZ	Distance bush DZ/FZ	ENTRETOISE TETE DE SCIE D	BUSSOLE DISTANZIATORE DZ	1
0001-54067-03	971105	Spannhülse DZ/FZ	Tensioning bush DZ/FZ	DOUILLE DE SERRAGE DZ/FZ	BUSSOLA DI SERRAGGIO DZ/F	1
0001-54101-01	974774	Lagerring DZ	Bearing ring DZ	Coussinet DZ	BUSSOLA DI SUPPORTO DZ	1
0001-54124-01	971118	Wasserleitung DZ/FZ	Water hose DZ/FZ	CANALISATION EAU DZ	TUBO ACQUA PORTATA	1
0001-54124-08	974777	Lagerdeckel DZ	Bearing lid DZ	Lagerdeckel DZ	COPERCHIO ALBERO ROT. DZ	1
0001-54225-02	971157	Büchse DZ/FZ	Sleeve DZ/FZ	MANCHON DZ	BUSSOLA ALB.MOT.DZ/FZ	1
0001-54310-03	971181	Dichtung Deckel Längsvor.	Gasket, lid	JOINT D'ETANCHEITE COUVER	GUARNIZ.CARTA.MOT.AVANZ.	1
0001-54553-01	976398	Schnecke LV 1:16	Worm	Vis sans fin LV 1:16	VITE SENZA FINE AVANZ. DZ	1
0001-54553-02	976399	Schneckenrad LV 1:16	Worm wheel	Roue de vis sans fin 1:16	INGRANAGGIO AVANZ. DZ	1
0002-51974-01	971203	Prisma Bronze	Guiding device (prism)	Glissoir en bronze	PRISMA AZ/FZ/DZ in ottone	1
0002-51974-01	971203	Prisma Bronze	Guiding device (prism)	Glissoir en bronze	PRISMA AZ/FZ/DZ in ottone	1
0002-51974-01	971203	Prisma Bronze	Guiding device (prism)	Glissoir en bronze	PRISMA AZ/FZ/DZ in ottone	2
0002-53859-01	971346	Schneckengehäuse DZ/FZ	Worm housing DZ/FZ	Carter vis sans fin DZ/FZ	BLOCCO ALU INGRANAGGI AV.	1
0002-54457-02	975924	HS-Typenschild klein	HS name plate small	HS-Petite plaque	HS-Typenschild klein	1
01A1-05045-00	971619	Distanzhalter M5x45	Spacer block M5 x 45	ENTRETOISE M5x45	DISTANZIALE M5X40	1
0111-04016-00	971680	Inbus-Schraube M 4x 16	Socket screw M 4x 16	Inbus-Schraube M 4x 16	VITE M 4x 16	4
0111-04016-00	971680	Inbus-Schraube M 4x 16	Socket screw M 4x 16	Inbus-Schraube M 4x 16	VITE M 4x 16	4
0111-05016-00	971691	Inbus-Schraube M 5x 16	Allen screw M5 x 16	Inbus-Schraube M 5x 16	VITE BRUGOLA M5X16	1
0111-05020-00	971693	Inbus-Schraube M 5x 20	Allen screw M5 x 20	Vis CHC M5x20	VITE BRUGOLA M5X20 DZ	2
0111-06012-00	971704	Inbus-Schraube M 6x 12	Allen screw	Vis CHC M6x12	VITE BRUGOLA M6X12 TENSIO	1
0111-06012-00	971704	Inbus-Schraube M 6x 12	Allen screw	Vis CHC M6x12	VITE BRUGOLA M6X12 TENSIO	1
0111-06016-11	971706	Inbus-Schraube M6x16 12.9	Allen screw M6x16	Vis CHC M6x16 12.9	VITE BRUGOLA M6X16 12,9	26
0111-06016-11	971706	Inbus-Schraube M6x16 12.9	Allen screw M6x16	Vis CHC M6x16 12.9	VITE BRUGOLA M6X16 12,9	3

99MS-60023-55	999997	WANDSÄGE DZ-S2	WANDSÄGE DZ-S2	WANDSÄGE DZ-S2	WANDSÄGE DZ-S2	11
0111-06020-00	971709	Inbus-Schraube M 6x 20	Socket screw M 6x 20	Vis CHC M6x20	VITE BRUGOLA M6X20	4
0111-06020-11	971710	Inbus-Schraube M6x20 12.9	Al. head screw M6x20 12.9	Vis CHC M6x20 12.9	VITE BRUGOLA M6X20 12,9	4
0111-06025-00	971711	Inbus-Schraube M 6x 25	Allen screw	is CHC M6x25	VITE BRUGOLA M6X25	1
0111-06025-00	971711	Inbus-Schraube M 6x 25	Allen screw	is CHC M6x25	VITE BRUGOLA M6X25	1
0111-06045-00	971716	Inbus-Schraube M 6x 45	Socket screw M 6x 45	is CHC M6x45	VITE BRUGOLA M6X45	4
0111-06045-00	971716	Inbus-Schraube M 6x 45	Socket screw M 6x 45	is CHC M6x45	VITE BRUGOLA M6X45	4
0111-06055-00	971719	Inbus-Schraube M 6x 55	Allen screw M 6 x 55	Vis CHC M6x55	VITE BRUGOLA M6X55	3
0111-08012-00	971729	Inbus-Schraube M 8x 12	Socket screw M 8x 12	Vis CHC M 8x 12	VITE M 8x 12	2
0111-08016-11	971732	Inbus-Schraube M8x16 12.9	Allen screw	VIS CHC M8 X 16 12.9 95	VITE BRUGOLA M8X16 12,9	6
0111-08020-00	979283	Inbus-Schraube M 8 x 20	Allen screw M8 x 20	Vis CHC M 8 x 20	VITE M 8 x 20	6
0111-08020-11	971735	Inbus-Schraube M8x20 12.9	Al. head screw M8x20 12.9	VIS CHC M8 X 20 12,9 95	VITE BRUGOLA M8X20 12.9	11
0111-10030-00	971765	Inbus-Schraube M10x 30	Allen screw M10 x 30	Vis CHC M10x30	VITE BRUGOLA M10X30	1
0112-06012-00	971808	Inb-Schr. Nied.Kopfm 6x12	Allen head screw M 6x12	VIS HC TETE RONDE M 6x12	VITE BRUG. M6X12 PRISMA	8
0112-06016-00	971809	Inb-Schr.nied.Kopfm 6x 16	Allen screw M 6x 16	Vis HC tête basse M6x16	VITE BRUG. M6X16 PRISMA D	2
0112-06016-00	971809	Inb-Schr.nied.Kopfm 6x 16	Allen screw M 6x 16	Vis HC tête basse M6x16	VITE BRUG. M6X16 PRISMA D	2
0112-06016-00	971809	Inb-Schr.nied.Kopfm 6x 16	Allen screw M 6x 16	Vis HC tête basse M6x16	VITE BRUG. M6X16 PRISMA D	4
0116-04006-23	971832	Inb-Schr.extr.n.Kopf M4x6	all.screwextr.filhd M4x6	VIS CHC tête plate M4x6	VITE BRUGOLA M4X6 BASSA	4
0116-05008-23	971834	Inb-Schr.extr.n.Kopf M5x8	Allen screw M5x8	IS CHC tête plate M5x8	VITE BRUGOLA M5X8 BASSA	1
01S1-16030-00	971937	6kt-Schraube M16x30	hex.-screw M16x30	Vis 6 pans M16x30	VITE ESAGON. M16x30 DZ/2	1
02L2-00040-08	971986	Kerbnagel 4x8	Wedge nail 4x8	Rivet 4x8	VITE M4x8 X LIVELLA	4
02S1-02512-50	971996	Seegering Welle Dm 25	seeger ring shaft dia 25	CIRCLIPS ARBRE DIAMETRE 2	SEEGER DM 25 DZ/FZ	1
02S2-02110-50	972006	Seegering Bohr. Dm 21	Seeger ring dia. 21	Circlips int. diam 21 mm	SEEGER DM 21	1
02S2-04717-50	972013	Seegering Bohr. Dm 47	Seeger ring dia. 47	CIRCLIP INTERIEUR DIA 47	SEEGER DM 47 GS/D	1
02X5-04800-12	979404	STOPFEN Dm 48 GPN 350	filling dia 48 GPN 350	Stopfen Dm 48 GPN 350	Stopfen Dm 48 GPN 350	1
02Z2-08020-00	972055	Zylinderstift 8 m6 x 20	Straight pin	GOUPILLE 8m6x20	SPINA DZ/FZ	2
02Z2-08020-00	972055	Zylinderstift 8 m6 x 20	Straight pin	GOUPILLE 8m6x20	SPINA DZ/FZ	1
03D1-31215-00	968733	Druckfeder Dm 6.3x0.8x23	cp. spring dia6.3x0.8x23	Ressort diam. 6.3x0.8x23	OLLA X GUIDA Dm6.3x0.8x23	1
03D1-31215-00	968733	Druckfeder Dm 6.3x0.8x23	cp. spring dia6.3x0.8x23	Ressort diam. 6.3x0.8x23	OLLA X GUIDA Dm6.3x0.8x23	1
03D1-31290-00	968671	Druckfeder Dm 5x1x17	comp. spring dia 5x1x17	Ressort diam. 5x1x17	MOLLA X GUIDA Dm 5x1x17	1
03D1-31290-00	968671	Druckfeder Dm 5x1x17	comp. spring dia 5x1x17	Ressort diam. 5x1x17	MOLLA X GUIDA Dm 5x1x17	1
04B1-06000-00	979462	Kugel Dm 6	ball dia 6	Kugel Dm 6	SFERA DM 6 PER GUIDA	3
04B1-06000-00	979462	Kugel Dm 6	ball dia 6	Kugel Dm 6	SFERA DM 6 PER GUIDA	3
04R1-06906-00	972140	Rillen-Kugellager 6906	Deep groove ball bearing	Roulement à bille 6906	CUSCINETTO 6906 WTW	2
04R1-61805-00	972143	Rillen-Kugellag. 61805T	ball bear. 61805T	ROULEMENT A BILLE 61805 T	CUSCINETTO 61805 T	1
04R3-06205-10	977061	Ril.Kugell. 6205-2RS1-W64	Deep groove ball bearing	Roulement billes 6205-2RS	CUSCINETTO 6205 KW 10	1
04R3-06206-10	977062	Ril.Kugell. 6206-2RS1-W64	Deep groove ball bearing	Roulement billes 6206-2RS	CUSCINETTO 6206 KW 10	1

99MS-60023-55	999997	WANDSÄGE DZ-S2	WANDSÄGE DZ-S2	WANDSÄGE DZ-S2	WANDSÄGE DZ-S2	11
04V1-QJ304-00	972157	Vierpunktlager QJ304	Four point bearing	PALIER 4 POINTS QJ304	CUSCINETTO QJ304	1
04W1-00003-00	972159	Wellenmutter KM3	Storage lid	ECROU D'ARBRE KM3	DADO KM3 DZ	1
04W1-00004-00	974848	Wellenmutter KM4	Shaft nut	ECROU KM4	DADO ALBERO 14 DENTI AZ	1
04W2-00005-00	975954	Stop-Wellenmutter 25x1,5	Stop-Shaft nut	ECROU 25X1,5	DADO ALBERO DZ/FZ	1
04X1-00003-00	972164	Sicherungsblech MB3	Safety sheet metal	RONDELLE DE SECURITE NB3	LAMIERA DI SICUREZZA	1
04X1-00004-00	972165	Sicherungsblech MB4	Safety sheet metal	RONDELLE DE SECURITE MB4	LAMIERA DI SICUREZZA DZ	1
04Z3-03203-00	972179	Schrägkugellager 3203-2RS	Angular ball bearing	Roulement billes 3203-2RS	CUSCINETTO 3203-2RS	1
04Z3-03207-00	977651	Schrägkugellager 3207-2RS	Ang.ball bearing 3207-2RS	Roul. cont. obl. 3207-2RS	CUSCINETTO 3207 B-2RSR	1
05D1-40474-00	969142	Dichtring Dm 40x47x4	Sealing ring dia 40x47x4	Joint 40x47x4	ANELLO TENUTA 40X47X4	1
05D1-45524-00	969143	Dichtring Dm 45x52x4	Sealing ring dia 45x52x4	Joint Dm 45x52x4	ANELLO TENUTA 45X52X4	1
05L1-00085-50	968771	V-Dichtung TWVA-0085	V-Seal TWVA-0085	JOINT V TWVA-0085	V-RING FZ TWVA-0085	1
05O1-00050-25	972210	O-Ring 5x2,5 N 70	O-ring d.5x2,5 N 70	O-Ring 5x2,5 N 70	O-RING 5x2,5 N 70	4
05O1-00060-20	976437	O-Ring Dm 6x2 N 70	O-ring d.6x2 N 70	O-Ring Dm 6x2 N 70	O-RING 6x2 70 N	8
05O1-00070-25	972213	O-Ring 7x2,5 N 70	O-Ring 7x2,5 N 70	O-Ring 7x2,5 N 70	O-Ring 7x2,5 DZ-FZ	1
05O1-00070-25	972213	O-Ring 7x2,5 N 70	O-Ring 7x2,5 N 70	O-Ring 7x2,5 N 70	O-Ring 7x2,5 DZ-FZ	1
05O1-00160-25	972227	O-Ring 16x2,5 N 70	O-ring	O-Ring 16x2,5 N 70	O-RING 16x2,5 N 70	1
05O1-00200-25	972234	O-Ring 20x2,5 N 70	O-Ring 20x2,5 N 70	O-RING 20 X 2,5	O-Ring 20x2,5 DZ-FZ CR-3	1
05O1-00200-25	972234	O-Ring 20x2,5 N 70	O-Ring 20x2,5 N 70	O-RING 20 X 2,5	O-Ring 20x2,5 DZ-FZ CR-3	1
05O1-00300-25	972248	O-Ring 30x2,5 N 70	O-ring d.30x2,5 N 70	O-Ring 30x2,5 N 70	O-RING 30x2,5 N 70	1
05O1-00360-25	972256	O-Ring 36x2,5 N 70	O-Ring 36x2,5 N 70	O-Ring 36x2,5 N 70	O-Ring 36x2,5	1
05O1-00360-25	972256	O-Ring 36x2,5 N 70	O-Ring 36x2,5 N 70	O-Ring 36x2,5 N 70	O-Ring 36x2,5	1
05O1-00470-25	972266	O-Ring 47x2,5 N 70	O-Ring 47x2,5 N 70	O-Ring 47x2,5 N 70	O-RING 47x2,5 N 90	1
05O1-00670-25	969324	O-Ring 67x2,5	O-ring 67x2,5	O-Ring Dm 67x2,5	O-RING DM 65 X 2.5	1
05O1-01050-25	972294	O-Ring 105x2,5 N 70	O-ring d.105x2,5 N 70	O-Ring 105x2,5 N70	O-RING 105x2,5 N 70 DZ	1
05O1-01050-25	972294	O-Ring 105x2,5 N 70	O-ring d.105x2,5 N 70	O-Ring 105x2,5 N70	O-RING 105x2,5 N 70 DZ	3
05O1-01100-35	974850	O-Ring 110x3,5 N 70	O-Ring 110x3,5	O-Ring 110x3,5 N70	O-Ring 110x3,5 FZ	2
05O1-01266-26	972299	O-Ring 126,67x 2,62 N 70	O-Ring 126,67x 2,62 N 70	O-Ring 126,67x 2,62 N 70	O-RING 126,67x 2,62 N70 D	1
05S2-00300-70	972331	Sim.ring A 30/47/7 NBR RF	Shaft seal	Joint à lèvres 30/47/7	ANELLO TENUTA 30x47x7 NBR	1
05S2-00380-50	979580	Sim.ring A 38/54/5 NBR Rf	Retaining ring 38/54/5	Joint à lèvres A 38/54/5	ANELLO TENUTA 38x54x5 NBR	1
06S2-05012-01	972464	Schmiernippel H1 NPT 1/8	Grease nipple H1 NPT 1/8	GRAISSEUR H1 NPT 1/8	VALVOLA INGRASSAGGIO AZ	1
06S2-05012-01	972464	Schmiernippel H1 NPT 1/8	Grease nipple H1 NPT 1/8	GRAISSEUR H1 NPT 1/8	VALVOLA INGRASSAGGIO AZ	1
07D9-EL532-M8	968679	Flügelmutter M8	Fly nut M8	Ecrou papillon M8	POMELLO GUIDA M8	1
07D9-EL532-M8	968679	Flügelmutter M8	Fly nut M8	Ecrou papillon M8	POMELLO GUIDA M8	1
07S2-07013-14	972789	Stecknippel 1/4" A1-WR013	Plug-in nipple1/4A1-WR013	Coupleur 1/4 A 1-WR013	RACC.ACQUA MASCH.1/4" MA	1
13G4-11626-06	973616	Bügelgriff GN-565.1	Shackle crank	POIGNEE HCCB-4/DZ/FZ	IMPUGNATURA A MANIGLIA	2
13Z2-00720-28	969460	Zahnriemen GT 8M-720-28	Tooth belt for DZ-S	cour. crantée GT8M-720-28	CINGHIA DENTATA DZ-S	1
20HS-DS003	977065	Blattdeckel Zentralb.DZ-2	Bladeflange DZ-2,central	Flasque à vis centrale	FLANGIA DISCO 1 DADO DZ-2	1
20HS-DS011	961280	Sägeblattdeckel kpl.Dm164	Sägeblattdeckel kpl.Dm164	Sägeblattdeckel kpl.Dm164	Sägeblattdeckel kpl.Dm164	1

Ø 60 H7
Ø 80 mm
Ø 130 mm

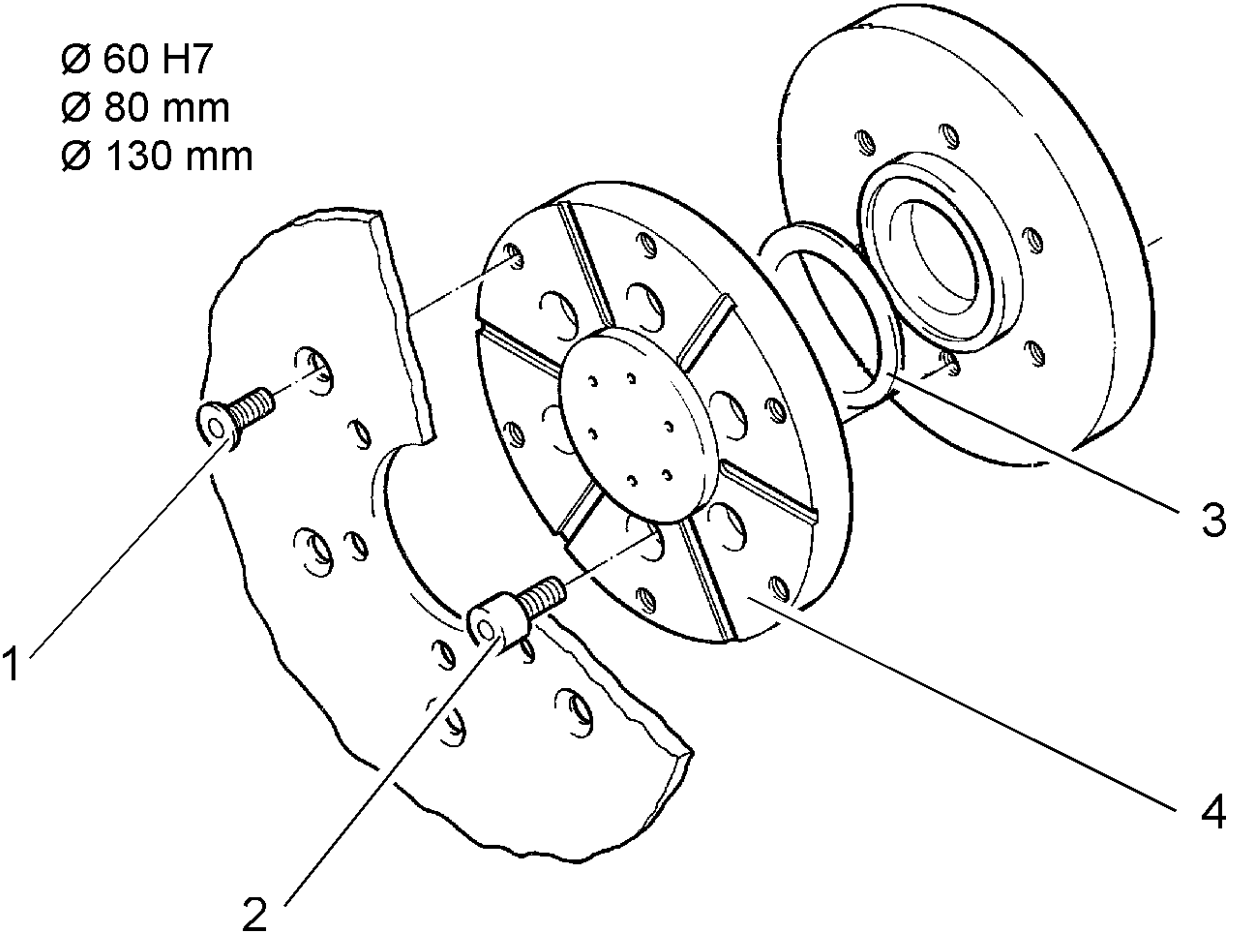

99MS-51973-00 Bündigschnittflansch Flush cut flange**Bride pour coupe à ras****Flangia per taglio a filo parete**

1	0114-08016-21	Senkkopfschraube	Countersunk head screw	Vis à tête fraisée	Vite a testa svasata	6	6xM8x16 10.9
2	0111-08016-11	Inbusschraube	Allen head screw	Vis à six pans creux	Vite ad esagono cavo	6	6xM8x16 12.9
3	0004-52650-01	Flachdichtung	Flat packing	Garniture plate	Guarnizione piatta		
4	0002-51967-01	Bündigschnittflansch	Flush cut flange	Bride pour coupe à ras	Flangia per taglio a filo parete		

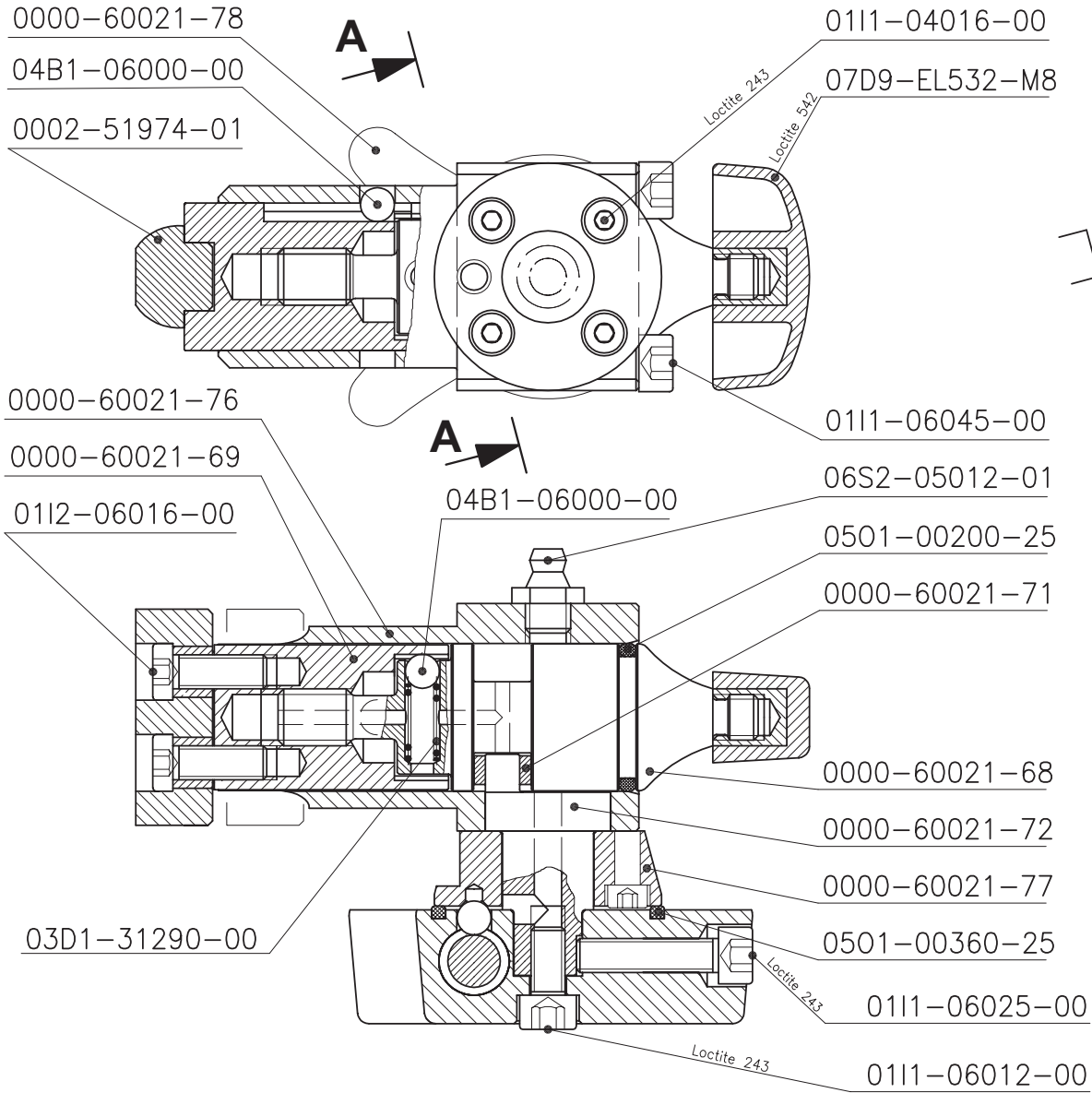

Schnitt A-A

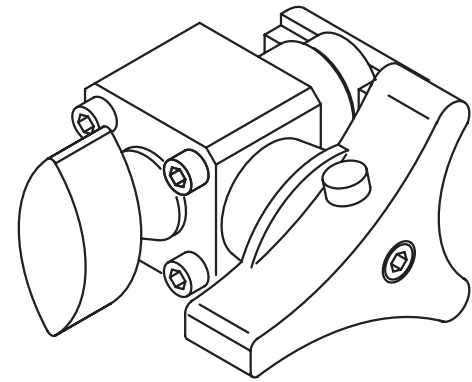
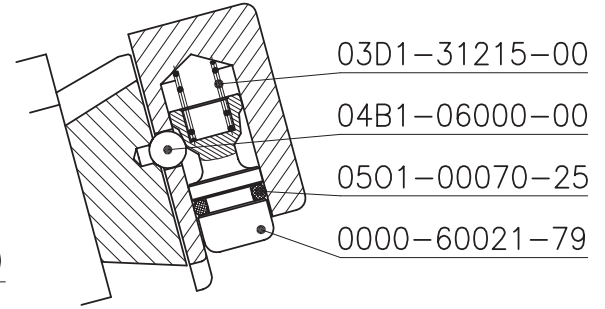

99MS-60021-93	963548	Y-Schlittenführung rechts	Glissière de char. Y droite	Y-Carriage guide right	Guida del carrello Y destra	pcs.
0000-60021-68	977717	Exzenterwelle (Raster)	ECentricshaft (Raster)	Arbre excentrique	ALBERO A TACCHE X GUIDA	1
0000-60021-69	977718	Prismenschieber (Raster)	Prism slide (grid)	Vanne prismatique	CURSORE A TACCHE GUIDA	1
0000-60021-71	977719	Druckplatte	pressure Plate	Cale de répart. de pressi	PIASTRA DI PRESS. PER GUI	1
0000-60021-72	977720	Exzenter	Excentre disc	Excentre disque	ECCENTRICO GUIDA	1
0000-60021-76	977724	Gehäuse	Housing	Carter	SCATOLA GUIDA	1
0000-60021-77	977725	Rasterplatte	Latch plate	Plaque moteur	PIASTRA A TACCHE	1
0000-60021-78	977726	Griff rechts	grip right	Poignée droite	MANIGLIA GUIDA DX	1
0000-60021-79	977727	Rastbolzen	Latchbolt	Axe d'arrêt	PULSANTINO GUIDA	1
0002-51974-01	971203	Prisma	Prisma	Prisma	Prisma	1
0111-04016-00	971680	Inbus-Schraube M 4x 16	Socket screw M 4x 16	Inbus-Schraube M 4x 16	VITE M 4x 16	4
0111-06012-00	971704	Inbus-Schraube M 6x 12	Allen screw	Vis CHC M6x12	VITE BRUGOLA M6X12 TENSIO	1
0111-06025-00	971711	Inbus-Schraube M 6x 25	Allen screw	Vis CHC M6x25	VITE BRUGOLA M6X25	1
0111-06045-00	971716	Inbus-Schraube M 6x 45	Socket screw M 6x 45	Vis CHC M6x45	VITE BRUGOLA M6X45	4
0112-06016-00	971809	Inb-Schr.nied.KopfM 6x 16	Allen screw M 6x 16	Vis HC tête basse M6x16	VITE BRUG. M6X16 PRISMA D	2
03D1-31215-00	968733	Druckfeder Dm 6.3x0.8x23	cp. spring dia6.3x0.8x23	Ressort diam. 6.3x0.8x23	MOLLA X GUIDA Dm6.3x0.8x23	1
03D1-31290-00	968671	Druckfeder Dm 5x1x17	comp. spring dia 5x1x17	Ressort diam. 5x1x17	MOLLA X GUIDA Dm 5x1x17	1
04B1-06000-00	979462	Kugel Dm 6	ball dia 6	Kugel Dm 6	SFERA DM 6 PER GUIDA	3
05O1-00070-25	972213	O-Ring 7x2,5 N 70	O-Ring 7x2,5 N 70	O-Ring 7x2,5 N 70	O-Ring 7x2,5 DZ-FZ	1
05O1-00200-25	972234	O-Ring 20x2,5 N 70	O-Ring 20x2,5 N 70	O-RING 20 X 2,5	O-Ring 20x2,5 DZ-FZ CR-3	1
05O1-00360-25	972256	O-Ring 36x2,5 N 70	O-Ring 36x2,5 N 70	O-Ring 36x2,5 N 70	O-Ring 36x2,5	1
06S2-05012-01	972464	Schmiernippel H1 NPT 1/8	Grease nipple H1 NPT 1/8	GRAISSEUR H1 NPT 1/8	VALVOLA INGRASSAGGIO AZ	1
07D9-EL532-M8	968679	Flügelmutter M8	Fly nut M8	Ecrou papillon M8	POMELLO GUIDA M8	1

0000-60021-86
04B1-06000-00
0002-51974-01

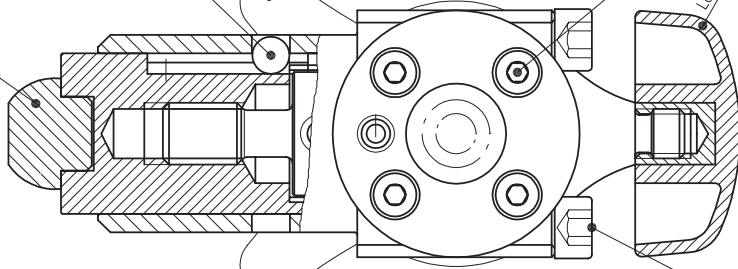

0111-04016-00
07D9-EL532-M8

Loctite 243
Loctite 542

Schnitt A-A

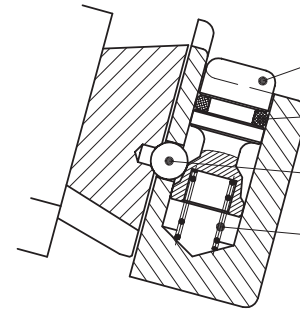

0000-60021-79
0501-00070-25
04B1-06000-00
03D1-31215-00

0000-60021-76
0000-60021-69
0112-06016-00

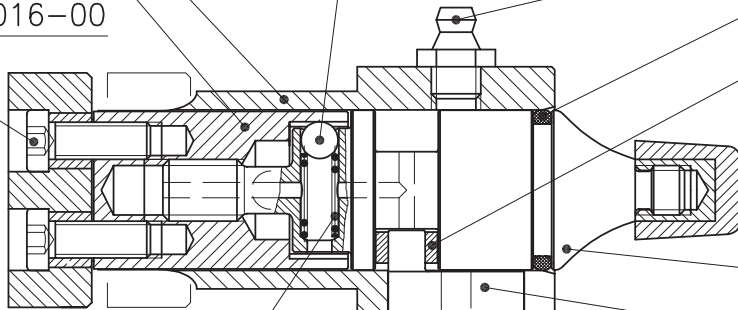

04B1-06000-00

0111-06045-00
06S2-05012-01

0501-00200-25
0000-60021-71

03D1-31290-00

0000-60021-68
0000-60021-72
0000-60021-77
0501-00360-25

Loctite 243

0111-06025-00
0111-06012-00

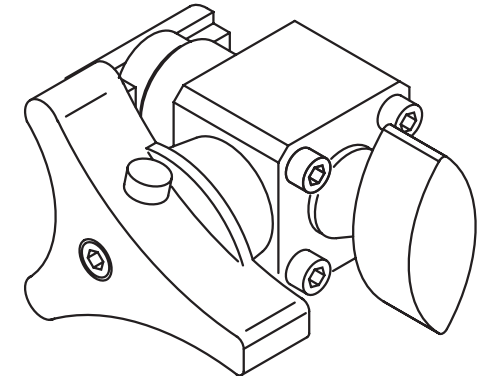

99MS-60021-94	963547	Y-Schlittenführung links	Gliss. de char. Y gauche	Y-Carriage guide left	Guida del carrello Y sinistra	pcs.
0000-60021-68	977717	Exzenterwelle (Raster)	ECentricshaft (Raster)	Arbre excentrique	ALBERO A TACCHE X GUIDA	1
0000-60021-69	977718	Prismenschieber (Raster)	Prism slide (grid)	Vanne prismatique	CURSORE A TACCHE GUIDA	1
0000-60021-71	977719	Druckplatte	pressure Plate	Cale de répart. de pressi	PIASTRA DI PRESS. PER GUI	1
0000-60021-72	977720	Exzenter	Excentre disc	Excentre disque	ECCENTRICO GUIDA	1
0000-60021-76	977724	Gehäuse	Housing	Carter	SCATOLA GUIDA	1
0000-60021-77	977725	Rasterplatte	Latch plate	Plaque moteur	PIASTRA A TACCHE	1
0000-60021-79	977727	Rastbolzen	Latchbolt	Axe d'arrêt	PULSANTINO GUIDA	1
0000-60021-86	977732	Griff links	grip left	Poignée gauche	MANIGLIA GUIDA SX	1
0002-51974-01	971203	Prisma	Prisma	Prisma	Prisma	1
0111-04016-00	971680	Inbus-Schraube M 4x 16	Socket screw M 4x 16	Inbus-Schraube M 4x 16	VITE M 4x 16	4
0111-06012-00	971704	Inbus-Schraube M 6x 12	Allen screw	Vis CHC M6x12	VITE BRUGOLA M6X12 TENSIO	1
0111-06025-00	971711	Inbus-Schraube M 6x 25	Allen screw	Vis CHC M6x25	VITE BRUGOLA M6X25	1
0111-06045-00	971716	Inbus-Schraube M 6x 45	Socket screw M 6x 45	Vis CHC M6x45	VITE BRUGOLA M6X45	4
0112-06016-00	971809	Inb-Schr.nied.KopfM 6x 16	Allen screw M 6x 16	Vis HC tête basse M6x16	VITE BRUG. M6X16 PRISMA D	2
03D1-31215-00	968733	Druckfeder Dm 6.3x0.8x23	cp. spring dia6.3x0.8x23	Ressort diam. 6.3x0.8x23	MOLLA X GUIDA Dm6.3x0.8x23	1
03D1-31290-00	968671	Druckfeder Dm 5x1x17	comp. spring dia 5x1x17	Ressort diam. 5x1x17	MOLLA X GUIDA Dm 5x1x17	1
04B1-06000-00	979462	Kugel Dm 6	ball dia 6	Kugel Dm 6	SFERA DM 6 PER GUIDA	3
05O1-00070-25	972213	O-Ring 7x2,5 N 70	O-Ring 7x2,5 N 70	O-Ring 7x2,5 N 70	O-Ring 7x2,5 DZ-FZ	1
05O1-00200-25	972234	O-Ring 20x2,5 N 70	O-Ring 20x2,5 N 70	O-RING 20 X 2,5	O-Ring 20x2,5 DZ-FZ CR-3	1
05O1-00360-25	972256	O-Ring 36x2,5 N 70	O-Ring 36x2,5 N 70	O-Ring 36x2,5 N 70	O-Ring 36x2,5	1
06S2-05012-01	972464	Schmiernippel H1 NPT 1/8	Grease nipple H1 NPT 1/8	GRAISSEUR H1 NPT 1/8	VALVOLA INGRASSAGGIO AZ	1
07D9-EL532-M8	968679	Flügelmutter M8	Fly nut M8	Ecrou papillon M8	POMELLO GUIDA M8	1

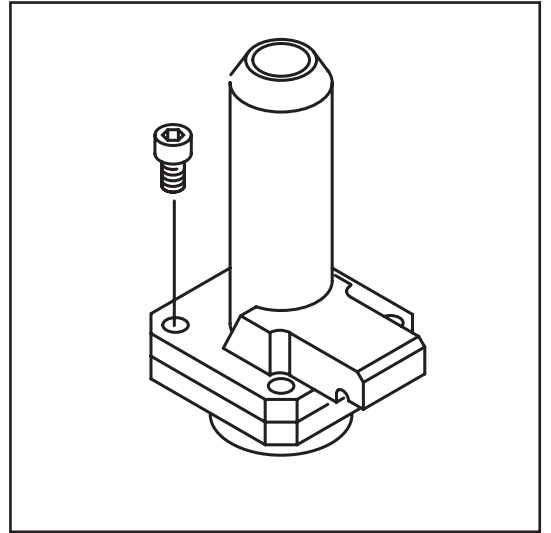
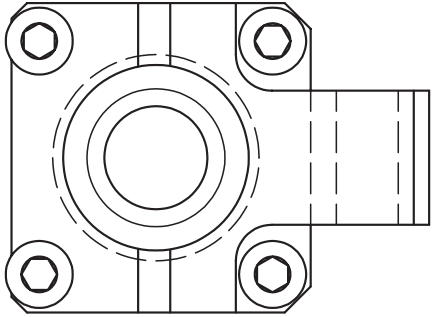
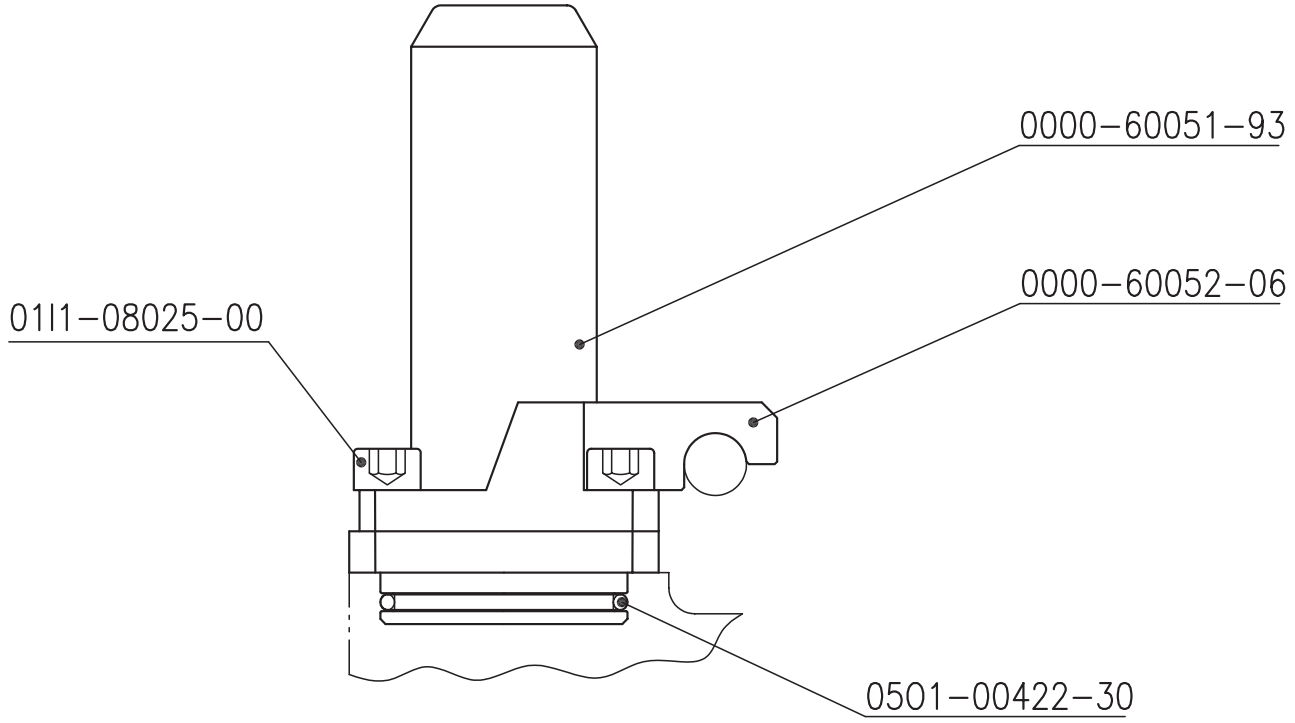

99MS-60051-43	977324	Blattschutzaufnahme	Blattschutzaufnahme	Blattschutzaufnahme	Blattschutzaufnahme	pcs.
0000-60051-93	977937	Zentrierbolzen	centering bolt	Zentrierbolzen	Zentrierbolzen	1
0000-60052-06	977949	Zentrierplatte	centering plate US	Zentrierplatte US	Zentrierplatte US	1
0111-08025-00	979284	Inbus-Schraube M8 x 25	Socket screw M 8x 25	Vis CHC M8x25	VITE M 8x 25	4
0501-00422-30	979549	O-Ring 42 x 3 N70	O-Ring 42 x 3 N70	O-Ring 42 x 3 N70	O-Ring 42 x 3 N70	1

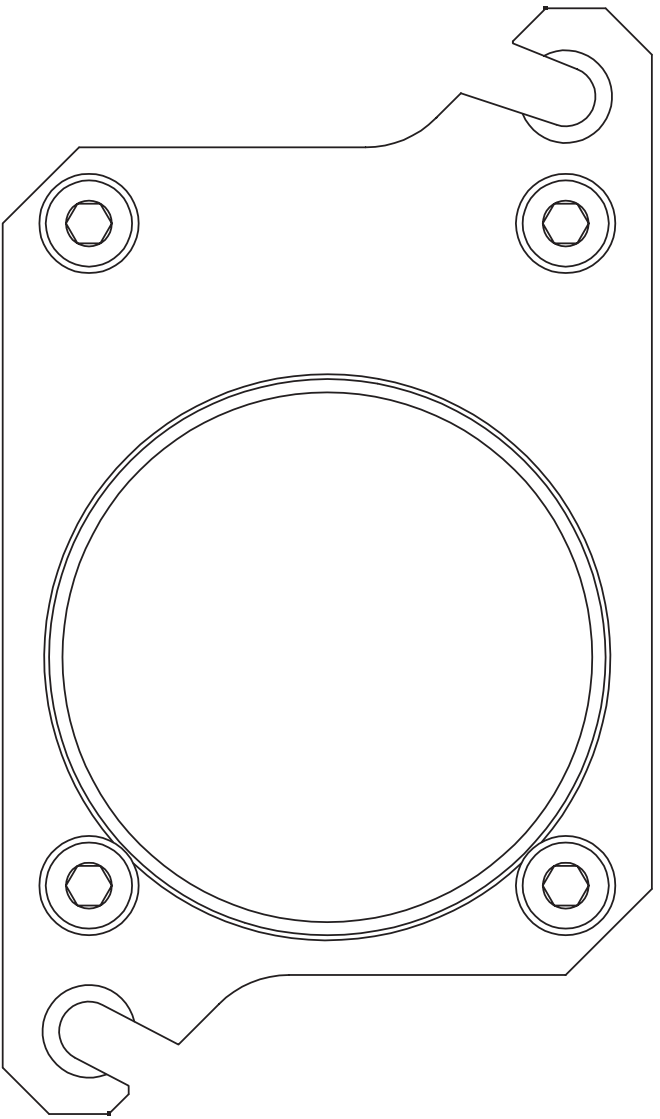

01M3-08000-60

01I6-08030-23

01U1-08015-50

0001-53391-01

0001-53391-03

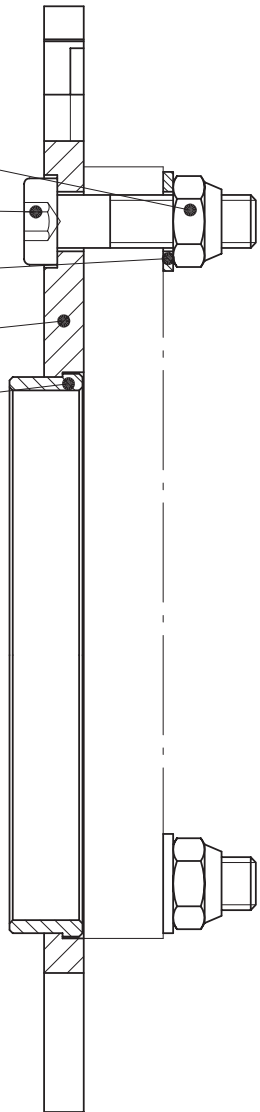

20HS-AZ006	973892	Gr.2 Schnellwechselsatz	Raccord rapide du moteur	Quick change set	Set per cambiamento rapido	pcs.
0001-53391-01	970942	Motorplatte AZ-S Schnellw	MotorPlate AZ-S rapid chg	Motorplatte AZ-S Schnellw	Motorplatte AZ-S Schnellw	1
0001-53391-03	970944	Zentrierring AZ-S Schnellw	centering ring AZ-S	CENTERING RING	Zentrierring AZ-S Schnellw	1
01I6-08030-23	971835	Inb-Schr.extr.n.KopfM8x30	all.screwextr.flhd M8x30	Vis HC Tête plate M8x30	VITE BRUGOLA M8X30 BASSA	4
01M3-08000-60	971861	Stop-Mutter M8 nied.Form	stop-nut M8 thin head	Ecrou Nylstop M8	DADO	4
01U1-08015-50	979353	U-Scheibe M8	washer M8	Rondelle M8	RONDELLA M8	4

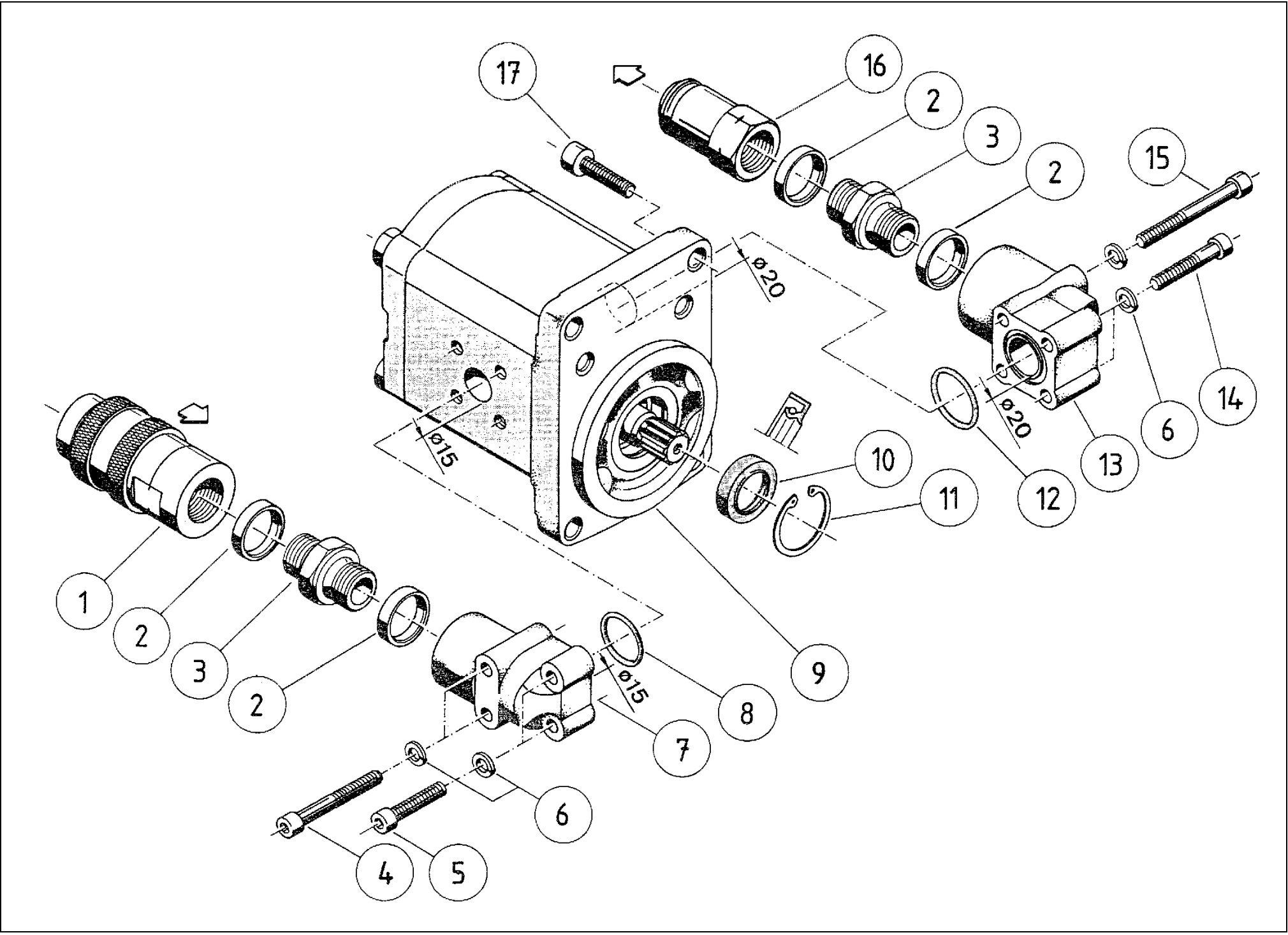

pos.	99MM-32005-__	Sägemotor Gr. 2	Saw motor Gr. 2	Moteur de sciage Gr. 2	Motore della sega	pcs.
1	07S1-00501-12	Kupplung	Coupling	Raccord femelle	Giunto	1
1A	07S1-00801-12	Kupplung FD Mut 1/2"	Coupling	Raccord femelle	Giunto	1
2	08D1-80341-12	Dichtring G 1/2"	Sealing ring	Anneau d'étanchéité	Anello di guarnizione	4
3	14D4-90201-12	Einschraubstutzen G1/2"-G1/2"	Screw-type connection piece	Manchon vissé	Gomito ad avvitamento	2
4	01I1-06045-00	Inbusschraube M6x45	Allen head screw	Vis à six pans creux	Vite ad esagono cavo	2
5	01I1-06030-00	Inbusschraube M6x30	Allen head screw	Vis à six pans creux	Vite ad esagono cavo	2
6	01F1-06000-50	Federring M6 DIN 127A	Spring washer	Rondelle élastique bombée	Rosetta elastica	8
7	07FI-61210-12	Motorflansch 2BK 1/2"-35	Motor flange	Bride de moteur	Flangia motore	1
8	05O1-00190-25	O-Ring 19x2,5	O-Ring	O-ring	Guarnizione OR	1
9	07M2-32205-__	Motor Bosch Gr 2	Motor	Moteur	Motore	1
10	05S1-00180-78B	Simmering	Shaft seal	Bague à lèvres avec ressort	Guarnizione anello albero	1
11	02S2-03015-50	Seegerring	Seeger circlip ring	Anneau de retenue type Seeger	Anello tipo Seeger	1
12	05O1-00220-25	O-Ring 22x2,5 N70	O-ring	O-ring	Guarnizione OR	1
13	07F1-61203-12	Motorflansch 2BK 1/2"-40	Motor flange	Bride de moteur	Flangia motore	1
14	01I1-06035-00	Inbusschraube M6x35	Allen head screw	Vis à six pans creux	Vite ad esagono cavo	2
15	01I1-06055-00	Inbusschraube M6x55	Allen head screw	Vis à six pans creux	Vite ad esagono cavo	2
16	07S1-00502-12	Nippel NS 502-BSP-F	Nipple	Raccord mâle	Raccordo	1
16A	07S1-00802-12	Nippel FD Vat.1/2"	Nipple	Raccord mâle	Raccordo	1
17	20D1-BOSOF-00	Dichtsatz Gr. F	Sealing kit	Jeu de garnitures	Set di guarnizione	1

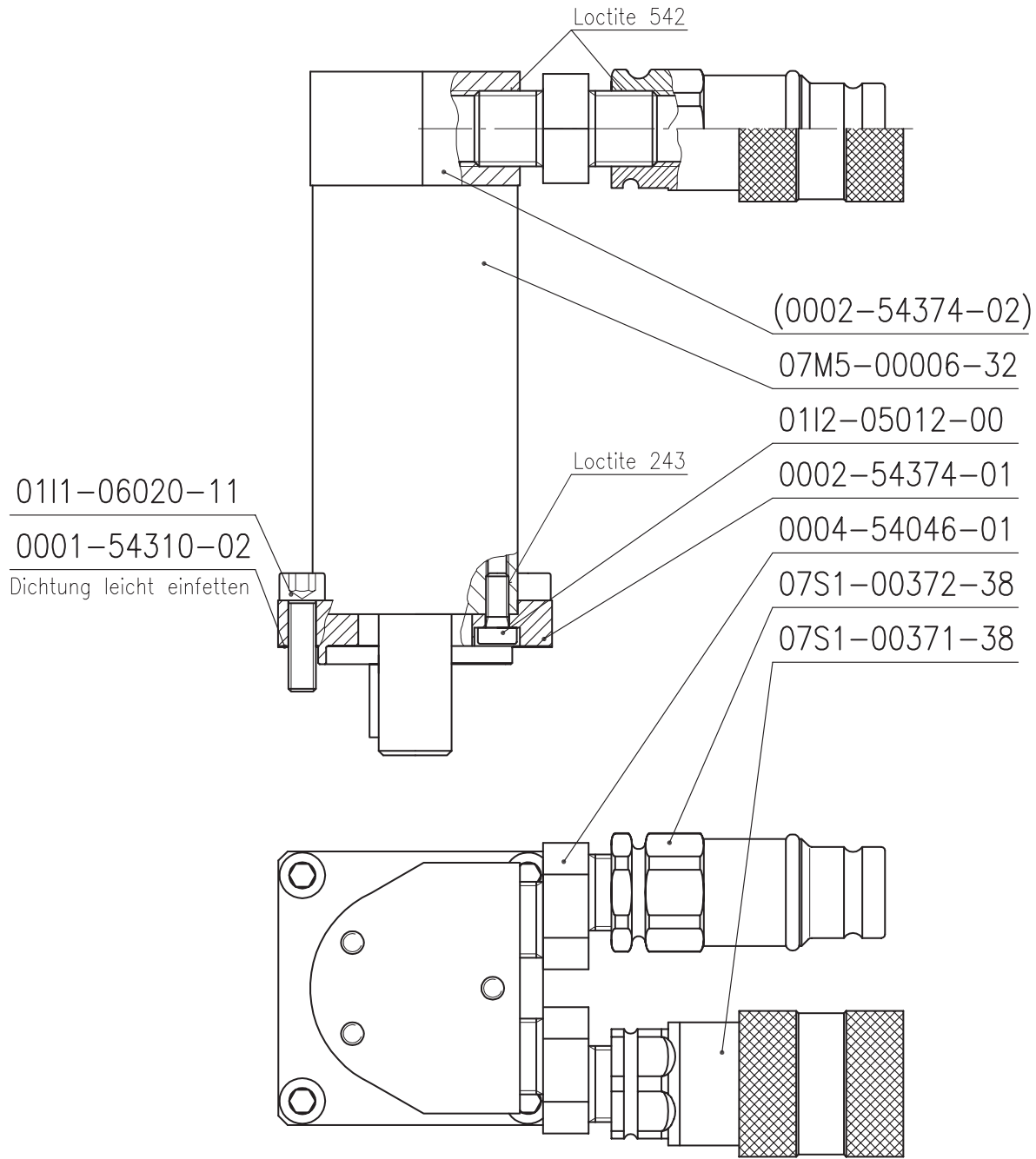

99MS-54565-01	976554	Vorschubmotor	Moteur d'avance	Feed advance motor	Motor d'avanzamento	pcs.
0001-54310-02	971180	Dichtung Vorschubmotor	Gasket, intake, engine	JOINT PAPIER MOTEUR AVANC	GUARNIZ.MOT.AVANZ.PENETRA	1
0002-54374-01	976402	Motorplatte OML Anbau	MotorPlate OML atthcmt	Plaque moteur OML	FLANGIA	1
0004-54046-01	971616	E-Nippel 3/8" NPT	E-nipple 3/8 NPT	MAMELON 3/8" DEPORTE	RACCORDO-E 3/8" DZ	2
0111-06020-11	971710	Inbus-Schraube M6x20 12.9	Al. head screw M6x20 12.9	Vis CHC M6x20 12.9	VITE BRUGOLA M6X20 12,9	4
0112-05012-00	971804	Inb-Schr.nied.KopfM 5x 12	allen screw flhd M 5x 12	Inb-Schr.nied.KopfM 5x 12	VITE M 5x 12	4
07M5-00006-32	976442	Hydraulikmotor OML 32	Hydraulic motor OML 32	Moteur hydraulique OML 32	MOTORE 32 OML	1
07S1-00371-38	979703	FF Kupplung 3/8 Zoll	Coupling 3/8	FF COUPLEUR 3/8	"RACCORDO BRUNING FEMM. 3/8	1
07S1-00372-38	979707	Nippel 3/8 Zoll	Nipple 3/9	Coupleur 3/8"	RACCORDO BRUNING MASCH.3/8	1

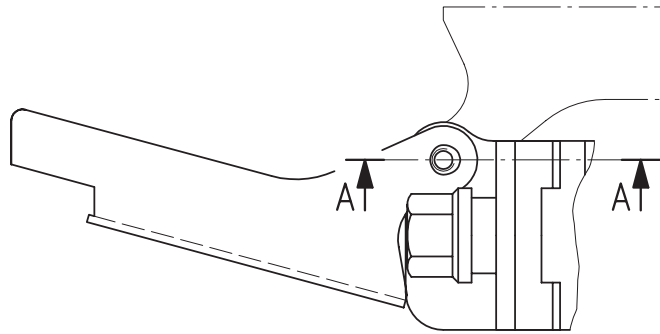
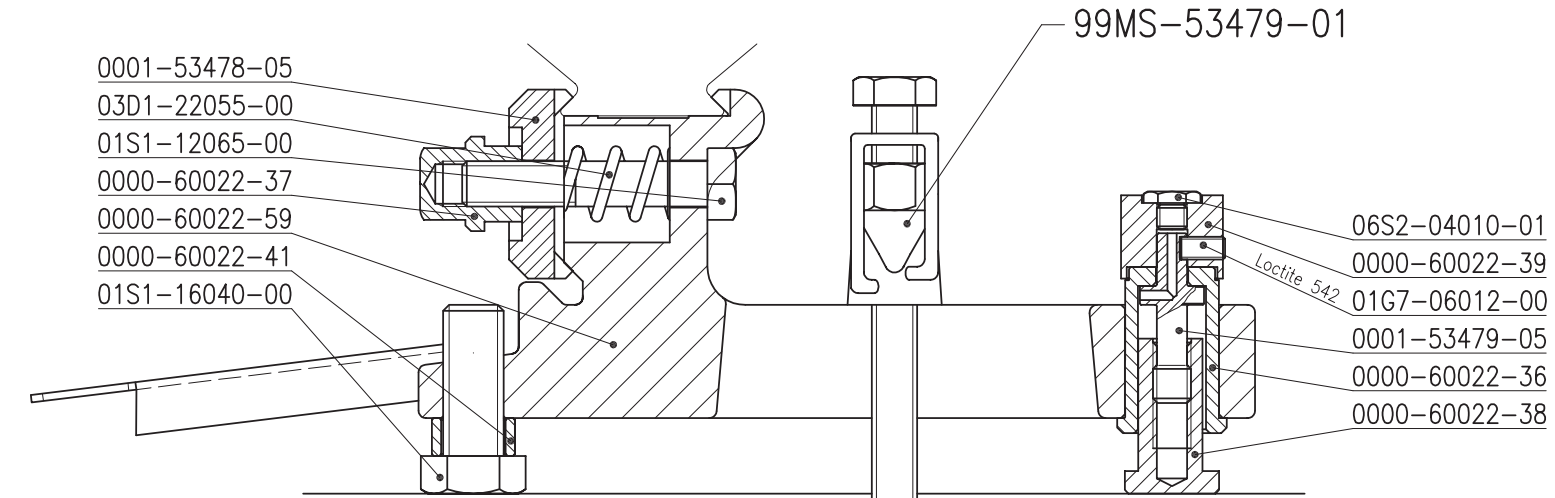

Schnitt A-A

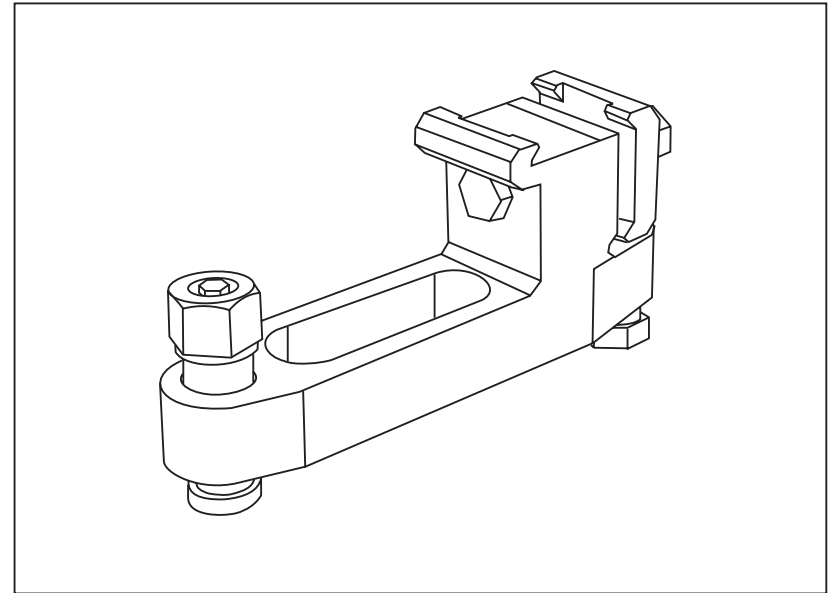
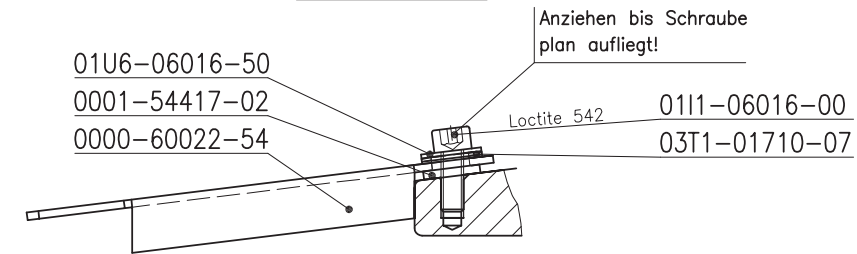

99MS-53675-01	974478	V-Schienenbock	V-track base	Sabot de fixation pour rail an V	Supporto die binari V	pcs.
99MS-53479-01	974476	Befestigungsklotz kpl.	Fixing block,cpl.	ENSEMBLE DE SERRAGE SABOT	VITE E FARFALLA COMPL N.S	1
0000-60022-36	961749	Führungsbüchse rostf.	Guide bushing staninless	Führungsbüchse rostf.	Führungsbüchse rostf.	1
0000-60022-37	961750	Hutmutter rostf.	Hutmutter rostf.	Ecrou borgne inox	DADO A CAPPELLO PIED. BIN	1
0000-60022-38	961751	Fuss rostf.	Fuss rostf.	Fuss rostf.	SUPPORTO PERNO PIED. AZ/S	1
0000-60022-39	961752	Spindelmutter rostf.	Spindelmutter rostf.	Spindelmutter rostf.	DADO DEL PERNO PIEDINO AZ	1
0000-60022-41	961753	Distanzring rostf.	Distanzring rostf.	Distanzring rostf.	Distanzring rostf.	1
0000-60022-54	968691	Zeiger Schienenbock	pointer for track foot	Aiguille sabot	ASTA CENTR.PIED.BIN.ALU	1
0000-60022-59	965449	Schienenbock (Stahlguss)	Schienenbock (Stahlguss)	Schienenbock (Stahlguss)	Schienenbock (Stahlguss)	1
0000-60060-50	978114	Mutter	nut M12 with seeger ring	Mutter	DADO FARFALLA SUPP.BIN.N.	1
0001-53478-05	974729	Klemmbride	Clamping strap	BRIDE DE SERRAGE SABOTS E	GANASCIA FISS. BIN. PIEDI	1
0001-53479-01	970969	Spannklotz	Tensioning block	BLOC TENDEUR SABOT " V	"FARFALLA VITE PIED. BINAR	1
0001-53479-05	970974	Spindel	Shaft	AXE DE REGLAGE DE SABOTS	PERNO FILET. REG. PIEDINO	1
0001-54417-02	975897	Zeigerbüchse	pointer bush	Zeigerbüchse	Zeigerbüchse	1
0003-54404-01	975931	Schnappfeder Befestigung	Catchspring fastening	Schnappfeder Befestigung	MOLLA BLOCCO FARF.SUPPORT	1
01G7-06012-00	971660	Gewindestift M 6x12	Set screw M 6 x 12	Clavette M6x12	GRANO M 6x12	1
0111-06016-00	971705	Inbus-Schraube M 6x 16	Socket screw M 6x 16	Vis CHC M6x16	VITE BRUGOLA M6X16	1
01S1-12065-00	971921	6kt-Schraube M12x65	Hexagonal screw M12x65	Vis 6 pans M12x65	VITE M12x65 PIEDINO B4-B6	1
01S1-12130-00	971931	6kt-Schraube M12x130mm	hex.-screw M12x130mm	VIS H M12x130	VITE M 12 X 130 T.E.	1
01S1-16040-00	971938	6kt-Schraube M16x40	hex.-screw M16x40	6kt-Schraube M16x40	VITE M16 X 40 PIEDINO BIN	1
01U6-06016-50	975949	U-Scheibe Dm 6.4/16x0.8	washer dia 6.4/16x0.8	U-Scheibe Dm 6.4/16x0.8	RONDELLA Dm 6.4/16x0.8	1
02S6-01511-50	979387	Seegerring 15V-Welle	seeger ring 15V-shaft	Seegerring 15V-Welle	SEEGER DADO FARFALLA SUPP	1
03D1-22055-00	979424	Druckfeder Dm 29.0x4.0	comp. spring dia 29.0x4.0	RESSORT 29.0x4.0	MOLLA NUOVO SUPPORTO	1
03T1-01710-07	969364	Tellerfeder Dm17/10/0.7	disk spring dia17/10/0.7	Tellerfeder Dm17/10/0.7	Tellerfeder Dm17/10/0.7	2
06S2-04010-01	972462	Schmiernippel D1 M8	Lubricating nipple	GRAISSEUR D1 M8	VALVOLA INGR. PIED. HCCB	1
7777-VERPA-11	980467	Verpackung V-Schienenbock	packaging V-track-foot	Verpackung V-Schienenbock	VERPACKUNG V-Schienenbock	1

- V-Schiene 700 kompl. 99MS-00700-11
- V-Schiene 1100 kompl. 99MS-01100-11
- V-Schiene 1400 kompl. 99MS-01400-11
- V-Schiene 1800 kompl. 99MS-01800-11
- V-Schiene 2200 kompl. 99MS-02200-11

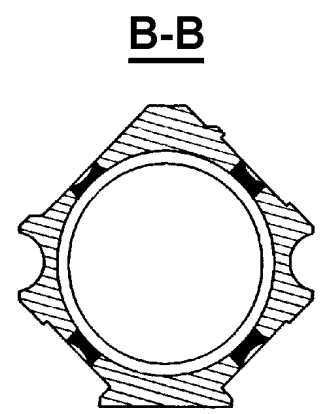
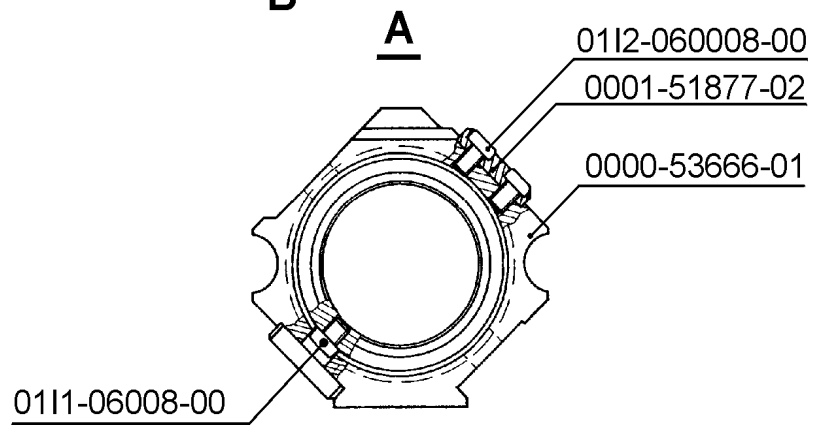
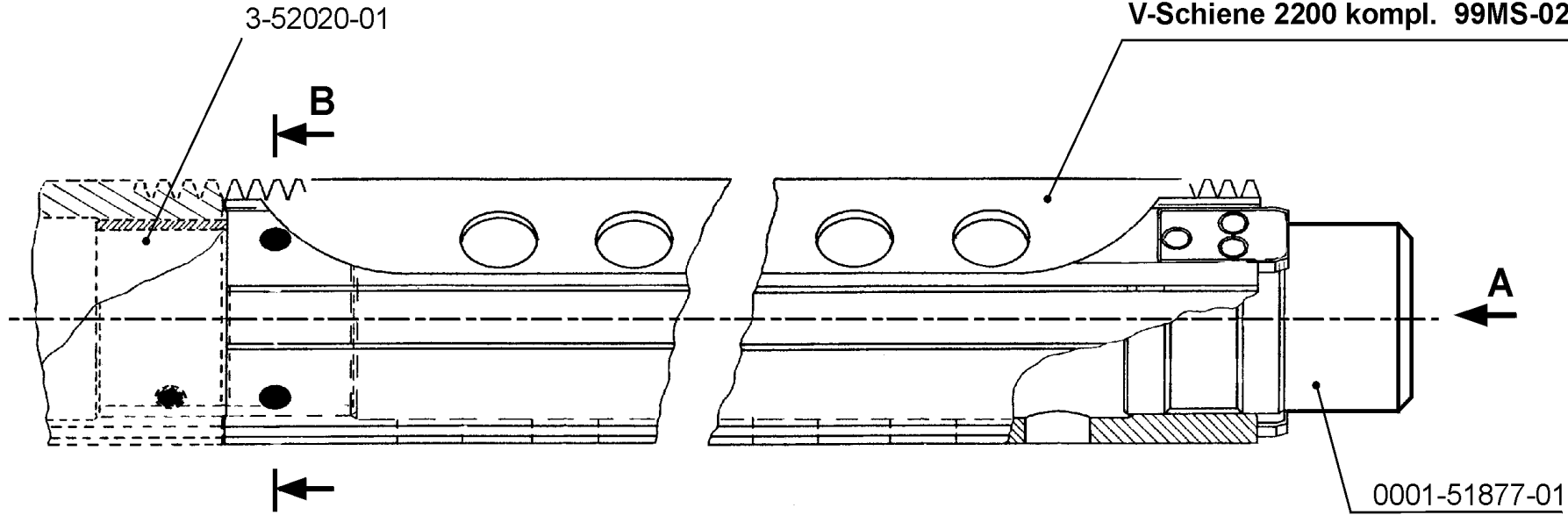

		VS-Schiene kpl.	VS-track compl.	Rail en VS complet	Binario VS compl.
99MS-00700-11	974398	V-Schiene VS kpl. 700	V-track VS compl. 700	Rail en VS complet 700	Binario VS compl. 700
99MS-01100-11	974400	V-Schiene VS kpl. 1100	V-track VS compl. 1100	Rail en VS complet 1100	Binario VS compl. 1100
99MS-01400-11	974402	V-Schiene VS kpl. 1400	V-track VS compl. 1400	Rail en VS complet 1400	Binario VS compl. 1400
99MS-01800-11	974404	V-Schiene VS kpl. 1800	V-track VS compl. 1800	Rail en VS complet 1800	Binario VS compl. 1800
99MS-02200-11	974406	V-Schiene VS kpl. 2200	V-track VS compl. 2200	Rail en VS complet 2200	Binario VS compl. 2200

03D1-22055-00

0000-60022-99

0000-60022-55

0000-60022-37

01S1-12040-00

0000-60022-98

01S1-12070-00

99MS-53479-01

01S1-12090-00

0000-60022-76

0000-60022-98

Loctite 270

Loctite 270

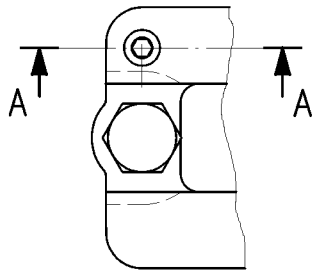

01U6-06016-50
0001-54417-02
0000-60022-54

Schnitt A-A

Anziehen bis Schraube
plan aufliegt!

Loctite 542

01I1-06016-00
03T1-01710-07

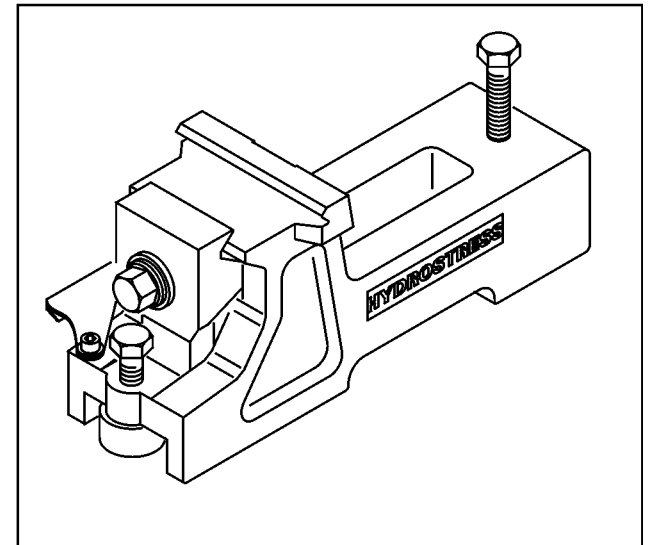
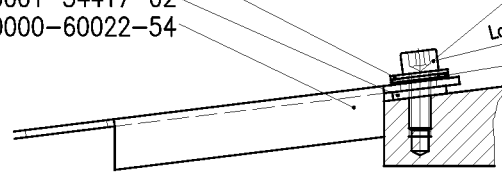

99MS-60022-77	965987	V-Schienenbock Alu flach	V-track base	Sabot de fixation pour rail an V	Supporto die binari V	pcs.
99MS-53479-01	974476	Befestigungsklotz kpl.	Fixing block,cpl.	ENSEMBLE DE SERRAGE SABOT	VITE E FARFALLA COMPL N.S	1
0000-60022-37	961750	Hutmutter rostf.	Hut nut stainless steel	Ecrou borgne inox	DADO A CAPPELLO PIED. BIN	1
0000-60022-54	968691	Zeiger Schienenbock	pointer for track foot	Aiguille sabot	ASTA CENTR.PIED.BIN.ALU	1
0000-60022-55	969447	Klemmscheibe	Clamp Disk	Klemmscheibe	RONDELLA SUPPORTO ALU	1
0000-60022-76	965778	Schienenbock ALU flach	Schienenbock	Schienenbock	Schienenbock	1
0000-60022-98	960837	Fuss	Fuss	Pied	PIEDINO A DADO	2
0000-60022-99	962806	Klemmbride Alu	Klemmbride Alu	Klemmbride Alu	GANASCIA PIEDINO ALU	1
0000-60060-50	978114	Mutter	nut M12 with seeger ring	Mutter	DADO FARFALLA SUPP.BIN.N.	1
0001-53479-01	970969	Spannklotz	Tensioning block	BLOC TENDEUR SABOT " V	"FARFALLA VITE PIED. BINAR	1
0001-54417-02	975897	Zeigerbüchse	pointer bush	Zeigerbüchse	Zeigerbüchse	1
0003-54404-01	975931	Schnappfeder Befestigung	Catchspring fastening	Schnappfeder Befestigung	MOLLA BLOCCO FARF.SUPPORT	1
0111-06016-00	971705	Inbus-Schraube M 6x 16	Socket screw M 6x 16	Vis CHC M6x16	VITE BRUGOLA M6X16	1
01S1-12040-00	979337	6kt-Schraube M12x40	hex.-screw M12x40	6kt-Schraube M12x40	VITE M12X40	1
01S1-12070-00	971922	6kt-Schraube M12x70	hex.-screw M12x70	Vis CHC M12x70	VITE M12x70	1
01S1-12090-00	971925	6kt-Schraube M12x90	hex.-screw M12x90	VIS H M12X90	6kt-Schraube M12x90	1
01S1-12130-00	971931	6kt-Schraube M12x130mm	hex.-screw M12x130mm	VIS H M12x130	VITE M 12 X 130 T.E.	1
01U6-06016-50	975949	U-Scheibe Dm 6.4/16x0.8	washer dia 6.4/16x0.8	U-Scheibe Dm 6.4/16x0.8	RONDELLA Dm 6.4/16x0.8	1
02S6-01511-50	979387	Seegerring 15V-Welle	seeger ring 15V-shaft	Seegerring 15V-Welle	SEEGER DADO FARFALLA SUPP	1
03D1-22055-00	979424	Druckfeder Dm 29.0x4.0	comp. spring dia 29.0x4.0	RESSORT 29.0x4.0	MOLLA NUOVO SUPPORTO	1
03T1-01710-07	969364	Tellerfeder Dm17/10/0.7	disk spring dia17/10/0.7	Tellerfeder Dm17/10/0.7	Tellerfeder Dm17/10/0.7	2
7777-VERPA-VE	980479	El.-Vorschub Verpackung	El.-feed packaging	El.-Vorschub Verpackung	El.-Vorschub Verpackung	1

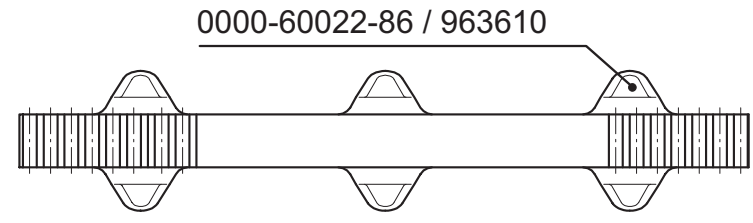

03R1-05012-00 / 972091

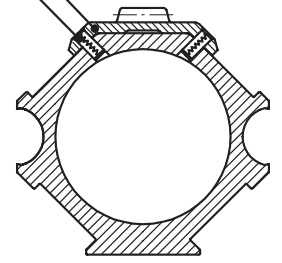

0000-60022-88 / 963612

0000-60022-94 / 963614

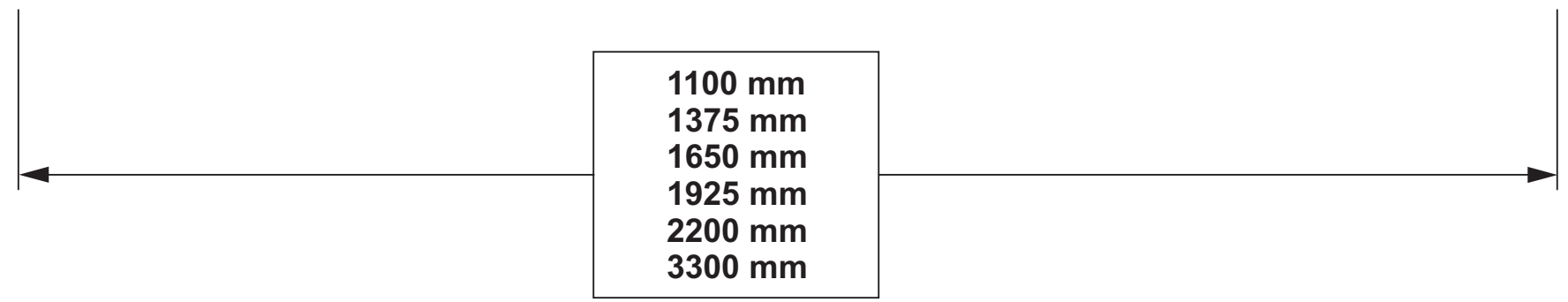
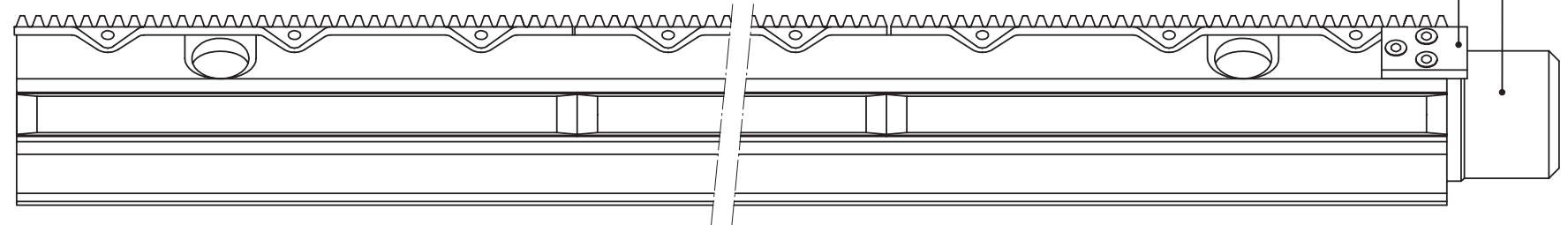

99MS-01100-VAS	984536
99MS-01375-VAS	984719
99MS-01650-VAS	984720
99MS-01925-VAS	984546
99MS-02200-VAS	984537
99MS-03300-VAS	999557

VAS-Schiene kpl.

V-Schiene VAS kpl. 1100
V-Schiene VAS kpl. 1375
V-Schiene VAS kpl. 1650
V-Schiene VAS kpl. 1925
V-Schiene VAS kpl. 2200
V-Schiene VAS kpl. 3300

VAS-track compl.

V-track VAS compl. 1100
V-track VAS compl. 1375
V-track VAS compl. 1650
V-track VAS compl. 1925
V-track VAS compl. 2200
V-track VAS compl. 3300

Rail en VAS complet

Rail en VAS complet 1100
Rail en VAS complet 1375
Rail en VAS complet 1650
Rail en VAS complet 1925
Rail en VAS complet 2200
Rail en VAS complet 3300

Binario VAS compl.

Binario VAS compl. 1100
Binario VAS compl. 1375
Binario VAS compl. 1650
Binario VAS compl. 1925
Binario VAS compl. 2200
Binario VAS compl. 3300

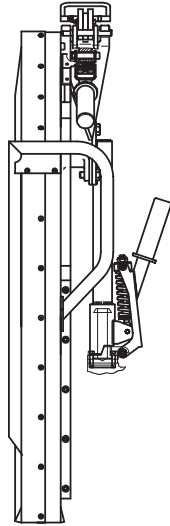
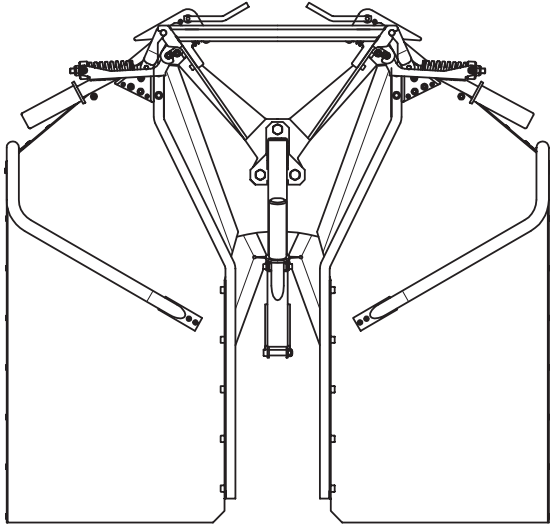

Ø 800 99MS-60111-10 / 999180
Ø 1000 99MS-60108-10 / 984240
Ø 1200 99MS-60105-10 / 962755

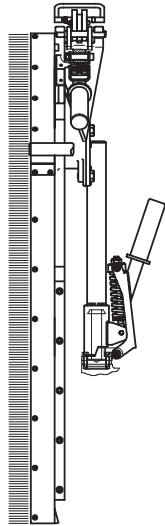
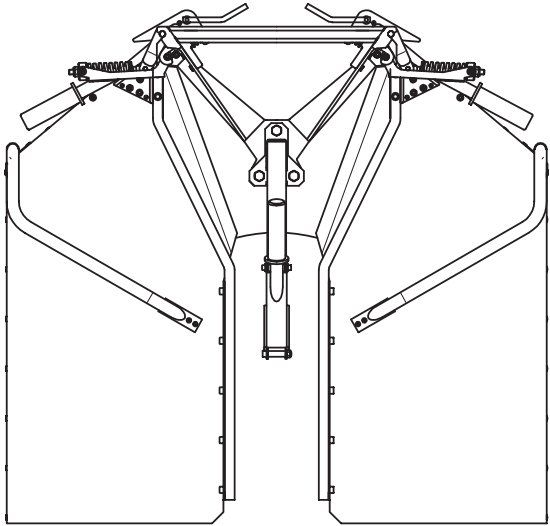

Ø 800 99MS-60111-80 / 999212
Ø 1000 99MS-60108-80 / 999160
Ø 1200 99MS-60105-85 / 999156