

FZ-4S wall sawing system

Index 001

Operating instructions
Spare parts list

0.1 Introduction

Dear Customer,

You have decided to buy a Hydrostress system and have thus acquired a highly sophisticated and reliable state-of-the-art unit.

Due to our special efforts in the field of quality assurance, the FZ-4S wall sawing system is a further Swiss, top-of-the-range product with the following properties:

- High sawing performance
- Reliable operation
- High portability
- Easy handling
- Low maintenance costs

The exclusive use of genuine Hydrostress spare parts ensures quality and interchangeability.

In the case of neglected or inappropriate maintenance, we refuse to accept any warranty commitment as specified in our terms of delivery.

Any repair work is to be carried out by trained personnel only.

Should you need more details concerning your Hydrostress system in order to keep it in perfect condition, please contact our after-sales service for further information.

We hope that you will not experience any problems while working with your Hydrostress system.

TYROLIT Hydrostress AG

Management

Copyright © HYDROSTRESS AG, May 2002

TYROLIT Hydrostress AG Witzbergstrasse 18 CH-8330 Pfäffikon Switzerland Phone +41 (0) 44 / 952 18 18 Fax +41 (0) 44 / 952 18 00
--

0.2 Validity of this manual

This operating manual is only valid for the following system:

FZ-4S wall sawing system Index 001

0.3 Standards

This operating manual has been prepared in accordance with CE Machinery Directive Appendix I and with the relevant standards in force at the time of printing.

0.4 Delimitation of the system

This operating manual also describes how to use to the blade guard and the rail system.

Drive unit operating instructions

Notes in this manual referring to the operation of drive units are designed to increase the safety of the operating personnel. To ensure that drive units are operated safely, however, it is essential to refer to the appropriate manual.

0.5	Table of contents		6	Saw blade unit for normal cutting	24
0.1	Introduction	2	6.1	Saw blades of up to 1000 mm diameter	24
0.2	Validity of this manual	2	6.2	Saw blades over 1000 mm diameter	25
0.3	Standards	2	7	Saw blade unit for flush cutting	26
0.4	Delimitation of the system	2	8	Mounting saw blade unit on wall saw	27
0.5	Table of contents	3	8.1	Mount saw blade unit	27
1	Safety instructions	4	9	Connecting the drive units	28
1.1	Fundamentals	4	10	Sawing	30
1.2	Before starting work	7	10.1	Before sawing	30
1.3	During sawing	8	10.2	The first cut (precut)	30
1.4	After the work	8	10.3	After the first cut	31
2	Technical data	9	10.4	Terminating the work	32
2.1	Dimensions	9	11	Disassembling saw blade unit	33
2.2	Measurements	9	12	Troubleshooting	35
3	Range of applications	10	13	Maintenance	37
3.1	Connectable units	10	13.1	Maintenance table	37
3.2	Possible applications	10	13.2	Change prism guides	38
4	Design and function	11	13.3	Change feed motor	38
4.1	Wall sawing system design	11	13.4	Exchange swivelling motor	38
4.2	Safety components	11	13.5	Change gear grease	39
4.3	Rail system	11	13.6	Repair	40
4.4	Wall saw head design	11	14	Transport, taking out of service, storage, disposal	41
4.5	Function	12	14.1	Transport	41
4.6	Controls and connections	14	14.2	Taking out of service and storage	41
4.7	Function (table)	15	14.3	Disposal	41
5	Set-up	16	15	Accessories	42
5.1	Initial start-up	16	15.1	Accessories available to order	42
5.2	Preparatory operations	16	15.2	Hydraulic drive motors	42
5.3	Selecting the saw blade	17	16	Spare parts list	43
5.4	Replacing saw motor	19	16.1	Ordering information	43
5.5	Mounting V-rails on concrete	20			
5.6	Fitting wall saw head	22			
5.7	Adjustment / Taking up play	23			
5.8	Removing the slide guides	23			

1 Safety instructions

1.1 Fundamentals

Qualification of operating personnel

Processing concrete is neither simple nor without risk. Material assets on the site, the machine itself and the safety of people are at stake.

The operating personnel must therefore be trained by experienced specialists. HYDROSTRESS can support you in your training.

Read the manual and inform your staff

This manual contains important information on how to operate the machine safely and efficiently.

The owner of the machine must make sure that the instructions in this manual are followed by anyone who has anything to do with the machine or the respective auxiliary and operating resources.

The manual must be available at all times where the machine is being used..

Hazards on the building site

The machine has been built in accordance with state-of-the-art standards and the recognized safety regulations. Nevertheless, its use may constitute a risk to the life and limb of the user or of third parties, or cause damage to the machine and to other property.

Pay attention to the particular working conditions on the building site. Protect yourself thoroughly and others under your responsibility against the many hazards!

Noise level

Depending on the working environment, the machine can cause excessive noise during operation. The noise can permanently harm the hearing of operating personnel and of other people nearby within a short time. Ear protectors must therefore always be worn while working.

Recognize warning signs

Pay attention to the following words, their symbol and their meaning:

Danger



Orders or prohibitions designed to prevent injury to personnel and material damage

Warning:

Orders or prohibitions designed to prevent **damage to the machine**

Important:

Information on how to **use** the machine **efficiently**.

Safety clothing

Safety clothing must always be worn when drilling, sawing, nibbling or compressing concrete or stone in order to protect against the following hazards:

Sources of danger	Protective clothing
Falling parts:	Helmet, steel-capped safety shoes
Moving, sharp-edged parts:	Safety gloves
Flying pieces of stone, flying sparks:	Safety glasses
Slipping:	Anti-slip shoes
Noise:	Ear protectors
Contamination of respiratory tracts:	Respiratory mask

Materials suitable for processing

Only the following materials are to be machined by HYDROSTRESS equipment:

- **Concrete and natural stone.**

Other materials are **not to be processed**.

Especially do not process:

- Wood, plastics and glass

Concrete and stone cutouts or drilling cores

These pieces can be very heavy.

1m³= 2400-2700 kg

Example:

A cube of concrete measuring 0.5 by 0.5 by 0.5 m weighs about 300 kg. A drilling core with a diameter of 30 cm and a length of 1 m weighs about 180 kg.

Make sure that these pieces cannot fall or tip over and cordon off the hazardous area.

Safety components

Never start up the machine without fitting the correct safety components (see “Safety components” section of these operating instructions manual).

Controls and accessories

Use the machine only with the recommended controllers or devices and accessories (see “Connectable Controls” and “Accessories” in this manual).

Local safety regulations

Pay attention to the general and specific safety regulations of your local trade associations.

1.2 Before starting work

Emergency stop

Make sure you know how to stop the machine quickly in case of emergency (see “Emergency stop” in this manual)!

First aid in case of accidents

Make sure you know how to alert first aid rapidly in case of an accident.

Water, gas and electric lines

Make sure that all supply lines are turned off in the area of your cut or drill hole! Find out whether it is permissible for such lines to be cut through.

Reinforcing rods

Make sure that it is safe and permitted to cut reinforcing rods in the area of your cut or drill hole.

Organising your workplace

Organise your workplace well. You will reduce the risk of accidents substantially.

Lighting of your workplace

Make sure you have sufficient lighting at your workplace.

Safe areas for operating personnel and other people

This machine is designed for one-person operation.

During processing, other people must keep at a safe distance from the machine.

The drive unit controller must be positioned so that all the operator’s controls are within easy reach.

It must be possible at any time to stop the machine rapidly and safely (see “Emergency stop”).

1.3 During sawing

Always fasten the saw blade with the screws supplied. Make sure you use screws of the correct dimensions and grade.

Never use saw blades with cracks! Cracked saw blades may break during sawing and endanger you and other people.

Motorized feed

Machines with motorized feed *are not* automatic machines. They must never be left unattended during operation. An emergency stop must be possible at all times.

Rotating and moving parts

To prevent being caught by rotating or moving parts, wear close-fitting clothes and a hair net if you have long hair.

1.4 After the work

When using electric drive units

Unplug the machine from the mains immediately after processing in order to prevent the drive unit being switched on unintentionally!

Removing concrete and stone sections

Use appropriate lifting gear to remove these sections, in order to prevent injuries.

2 Technical data

2.1 Dimensions

Weights

41.0 kg	Wall saw, incl. feed motors and quick-release flange excluding saw motor
5.50 kg	Saw motor size 2
7.75 kg	Saw motor size 3

Blade drive

Hydraulic motor	860 – 3250 rpm.
Ratio	1:3
Operating pressure	max. 260 bar

Movement

Hydraulic motor	-
Operating pressure	max. 120 bar
Feed force	max. 600 kg
Feed	Toothed wheel on rail

Swivelling

Hydraulic motor	-
Operating pressure	max. 120 bar
Swivelling range	360°
Feed force	300 kg

Rails

Length	70 cm
	110 cm
	140 cm
	180 cm
	220 cm
Hole spacing	10 cm

Cutting depths

Dia. 800 mm	no precut	31 cm
Dia. 1000 mm	no precut	40 cm
Dia. 1200 mm	with precut	50 cm
Dia. 1500 mm	with precut	67 cm
Dia. 1600 mm	with precut	72 cm
Dia. 1800 mm	with precut	82 cm
Dia. 2000 mm	with precut	92 cm
Dia. 2200 mm	with precut	102 cm

2.2 Measurements

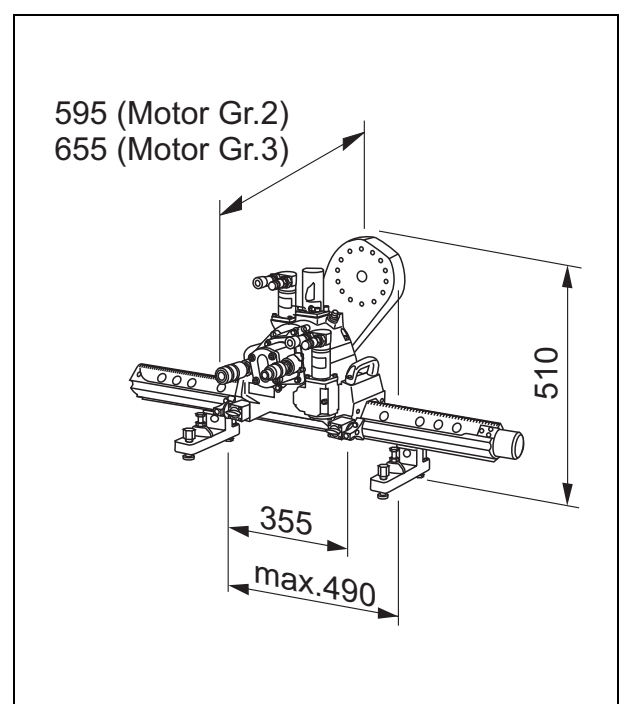

3 Range of applications

3.1 Connectable units

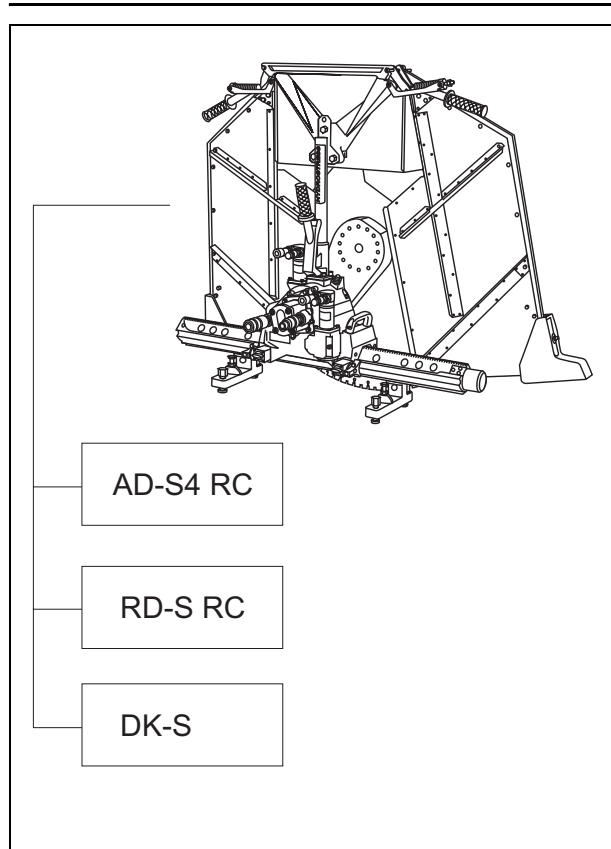

Special features of the various drive units

The drive units vary in their performance. For optimum cutting performance the correct saw motor must be selected (see “Selecting saw motor”) according to the unit used and the planned application.

AD-S4 RC	4 stages (2 mains voltages)
RD-S RC / DK-S	4 stages

3.2 Possible applications

- Parting cuts
- Flush cuts
- Inclined cuts
- Joint cuts



This machine is not designed for other applications and may be cause particular hazards under specific circumstances.

4 Design and function

4.1 Wall sawing system design

The FZ-4S wall sawing system comprises:

- Wall saw head
- Blade guard
- Rail system

Wall saw head

The wall saw head contains all the hydraulic and mechanical parts for:

- Blade drive
- Travelling motion
- 360° swivelling motion

4.2 Safety components

Blade guard, three-piece, collapsible

- folding
- removable side wing
- 800mm, 1000mm or 1200mm, normal and flush
- in aluminium

Two-piece blade guard

- 1380, 1600, 2200 mm
- in aluminium
- also suitable for flush cutting

4.3 Rail system

- Anchoring to concrete with clamping block and dowel screw

4.4 Wall saw head design

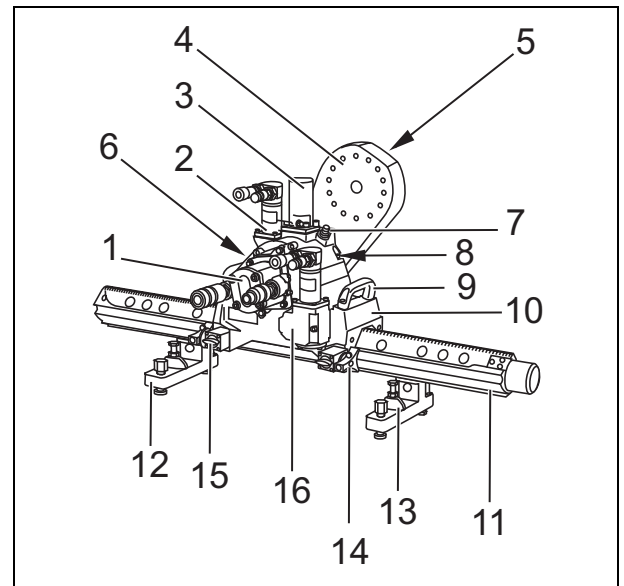

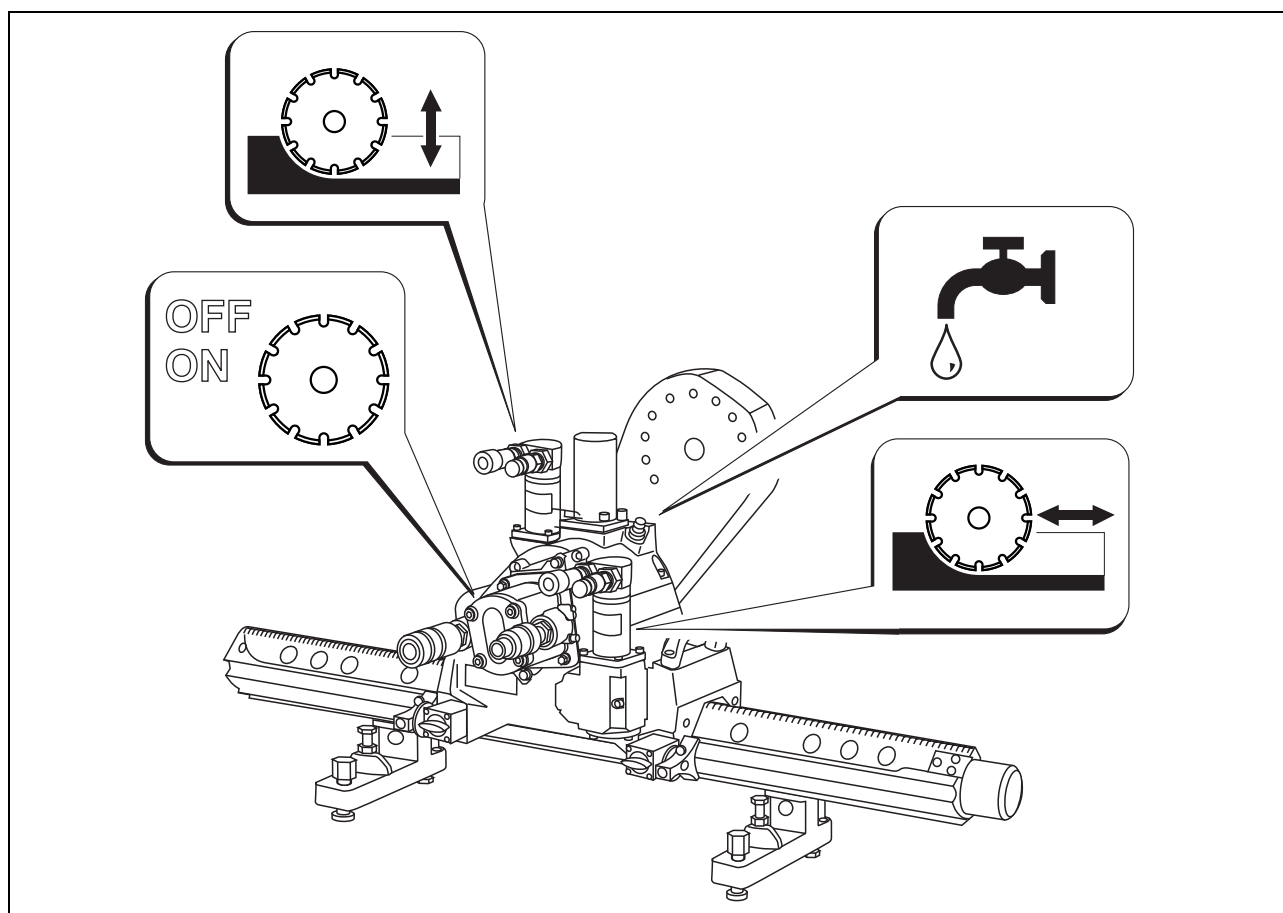

1. Saw motor
2. Swivelling motor
3. Blade guard seat
4. Swivel arm
5. Toothed gearing (blade drive)
6. Gear housing (swivel gear)
7. Water connection
8. Overload protection
9. Grip
10. Chassis
11. V-rail
12. V-rail support
13. Anchoring block
14. Y-grip
15. Feed grip
16. Feed gears (travelling gears)

4.5 Function

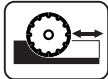
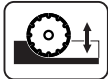

Swivel arm should only be moved if the blade flange has been fitted. Otherwise there is a risk of damage to the machine from the protruding locking sleeve.

Function (table)

This.... by means of this drives this	Remarks
Saw blade drive 			
Main circuit	Hoses	Saw motor	Direction of rotation is set
Saw motor	Toothed gearing	Saw blade	Ratio 1:3
Feed on rail 			
Feed circuit	Hoses	Feed motor	Set direction of feed and speed on the unit
Feed motor	Worm drive	Toothed wheel	Toothed wheel engages on rail
Swivelling of wall saw head 			
Swivel feed	Hoses	Swivelling motor	Set direction of swivel and speed on the unit
Swivelling motor	Worm drive	Swivel arm	360° swivel
Water 			
Drive unit	Hose	Coupling to saw head	Adjust water on unit
Coupling to saw head	Line to swivel arm	Swivel arm	Central water supply

4.6 Controls and connections

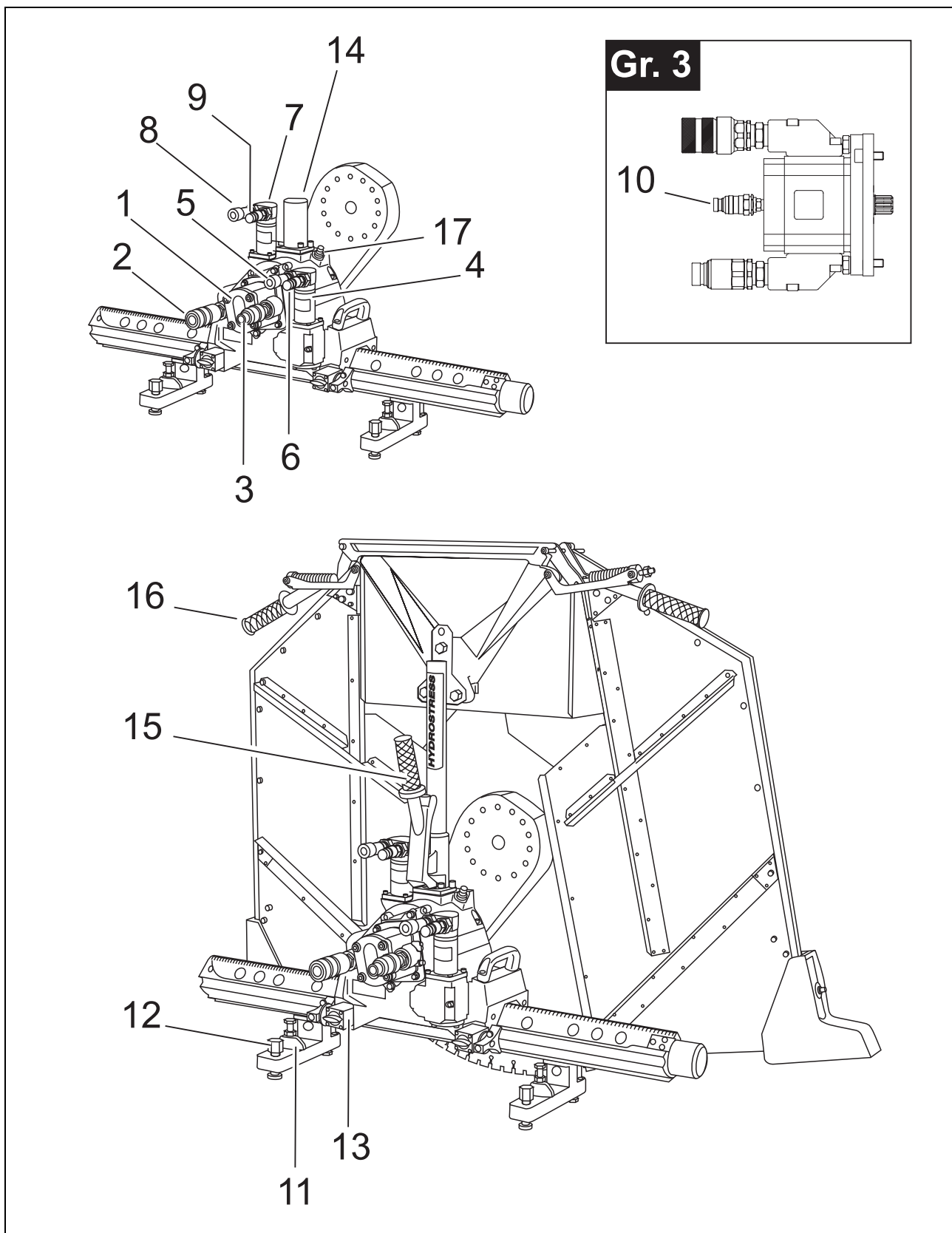

4.7 Function (table)

Pos. no.	Designation	Function
1	Saw motor	Saw blade drive
2	Saw motor coupling	Main circuit oil inlet
3	Saw motor nipple	Main circuit oil outlet
4	Feed motor (travel)	Drive (travelling motion)
5	Feed motor coupling	Feed circuit oil inlet or outlet (feed direction)
6	Feed motor nipple	Feed circuit oil inlet or outlet (feed direction)
7	Feed motor (swivel)	Drive (swivelling motion)
8	Feed motor coupling	Feed circuit oil inlet or outlet (swivel direction)
9	Feed motor nipple	Feed circuit oil inlet or outlet (swivel direction)
10	Leak oil nipple	Leak oil recycling
11	Clamping block with dowel screw	V-rail anchoring
12	Adjustment screws	Compensation for uneven floor
13	Feed grip	Adjustment of play between wall saw head and rail
14	Blade guard seat	Seat for blade guard
15	Clamping handle	Lock / release blade guard
16	Clamping handle	Lock / release side wing
17	Water connection	Water supply (cooling water)



Emergency stop

The wall sawing system can only be shut down on the drive unit. Follow the operating instructions of the unit you are using.



Swivel arm should only be moved if the blade flange has been fitted. Otherwise there is a risk of damage to the machine from the protruding locking sleeve.

5 Set-up

5.1 Initial start-up

The wall sawing system is delivered ready for use. All instructions in this chapter are equally valid at the initial start-up.

5.2 Preparatory operations

Always proceed as follows:

- Sort out fundamental conditions
- Secure the site
- Decide on position and sequence of the cuts
- Select saw blade
- Carry out a visual inspection

Always pay detailed attention to the following before using the system:

Position of supply lines

- Determine the position of pipes and cables in walls and ceilings.

Water

Where does the cooling water used for sawing flow to?

- Think about water damage to the electrical supply.

Secure the site

- Secure the area where the wall sawing system will be used.
- Access by those not involved should be prevented.
- When cutting walls consider the other side of the wall.
- Secure this area as well.

Securing cutouts

- Secure cutouts from walls and especially from ceilings by suitable means, e.g. crane, supports, etc.
- Check the weight of concrete. (1m³= 2400-2700 kg)

Position of cuts

- Find out about the concrete to be sawed:
 - Where does the reinforcement run?
 - Is it heavily or lightly reinforced?
 - Is it suitable for steel plug fixing?
- Decide on the position and sequence of cuts before starting work. For example, for a door cutout carry out the bottom cut first, then the side cuts and finally the top cut.

Cut across the reinforcement if possible

The wrong sequence of cuts can lead to jamming of the blade or to damage to the equipment.

Rail length

- Determine the rail length for the intended cut.
- Leave sufficient projection for the wall saw head.

5.3 Selecting the saw blade

- Select the saw required blade diameter according to the requirements of the cut and the technical conditions.

Precut

A precut of dia. 800 mm is recommended for all work.

Anchoring options for saw blades

External dia.: 450 - 2200 mm
 Dia. location hole: 60 H7 mm

Quick-release flange for normal cuts
up to dia. 1000 mm

2 x M12 hexagon head cap screw with blade cover

Quick-release flange for normal cutting
from dia. 1000 mm

6 x M8 countersunk head screw on dia. 130mm graduated circle
 2 x M12 hexagon head cap screw with blade cover

Quick-release flange for **flush cutting**

6 x M8 countersunk head screw on dia. 130mm graduated circle



Use the following screws only:
 Countersunk head screw M8x16, grade 10.9, order No. 97182.

Use the following screws only:
 Hexagon head cap screw M12x35, order no. 969911

Anchoring saw blade unit to wall saw

Saw blade with quick-release flange to wall saw 1 x central screw

Use the following screws only:
 Central screw M12x70, order no. 999255

What cutting depth do you want to achieve?

The "Cutting depth" table shows how big the saw blade must be according to the cutting depth.

Saw blade dia.	Cutting depth	Precut required?
800	30	No precut required
900	35	
1000	40	
1200	50	Precut with small blade required
1500	67	
1600	72	
1800	82	
2000	92	
2200	102	

Cutting depth example

Sawing an opening in a 35 cm thick concrete wall:

- The saw blade must be **900 mm** in size (see "Cutting depth" table).
- At the maximum plunging depth the saw blade will have a **30 cm overlap** at both ends of the cut (see "Overlap" table).

How big is the overlap?

The “Overlap” table shows by how much the saw blade overlaps at both ends of the cut,

according to the plunging depth and the size of the saw blade.

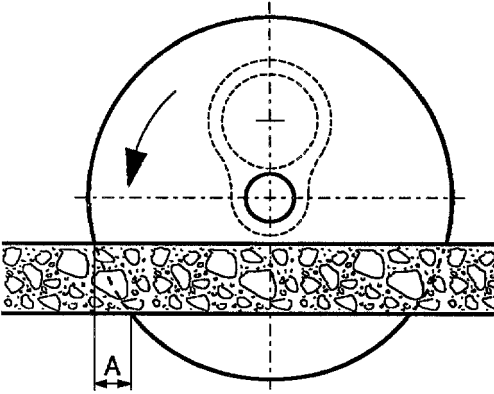
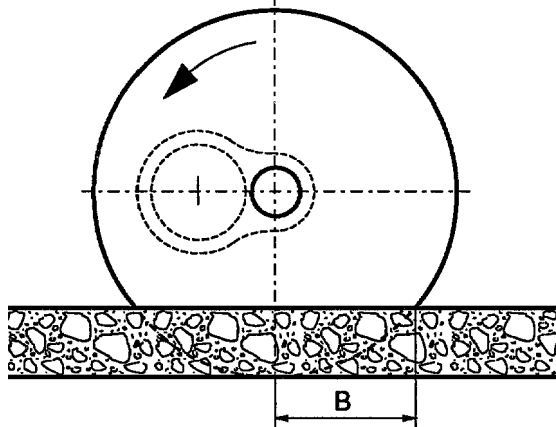
		Saw blade with max. plunge									Saw blade with min. plunge								
																			
		Size of saw blade									Size of saw blade								
Concrete thickness in cm		Dia. 500	Dia. 600	Dia. 750	Dia. 800	Dia. 900	Dia. 1000	Dia. 1200	Dia. 1500	Dia. 500	Dia. 600	Dia. 750	Dia. 800	Dia. 900	Dia. 1000	Dia. 1200	Dia. 1500		
	5		2	2	2	2	1	1	1	1	15	15	18	18	20	21	21	27	
10		6	5	4	4	3	3	3	2	20	22	25	26	28	29	32	37		
15		14	10	7	7	5	5	4	3	23	25	29	31	32	35	39	45		
20		-	18	12	11	9	8	7	5	-	28	33	34	37	39	44	51		
25		-	-	19	17	13	12	10	7	-	-	35	36	43	43	49	56		
30		-	-	-	26	20	17	13	10	-	-	-	38	43	45	52	60		
35		-	-	-	-	30	24	18	13	-	-	-	-	44	47	54	64		
40		-	-	-	-	-	36	24	17	-	-	-	-	-	48	55	67		
45		-	-	-	-	-	-	31	22	-	-	-	-	-	-	57	69		
50		-	-	-	-	-	-	44	27	-	-	-	-	-	-	58	71		
55		-	-	-	-	-	-	-	34	-	-	-	-	-	-	-	73		
60		-	-	-	-	-	-	-	43	-	-	-	-	-	-	-	73		

5.4 Replacing saw motor

Disassemble saw motor



Never connect or disconnect hoses when the drive unit is running.

- Switch off drive unit
- Reduce pressure (see drive unit operating instructions)
- Uncouple hoses from saw motor
 - Rotate locking ring
 - Hold hose straight
 - Slide back coupling sleeve
 - Pull off hose

Keep hose couplings clean and never allow them to drop.
Do not uncouple hoses at the drive unit side, so that pressure can be reduced via the drive unit.

- Loosen Allen screws.
- Rotate saw motor and remove.

Mount saw motor (size 2)

- Position saw motor with toothed profile coupling on the drive shaft and rotate
- Tighten M8 Allen screws

Mount saw motor (size 3)

- Position saw motor on the drive shaft and rotate
- Tighten M12 Allen screws

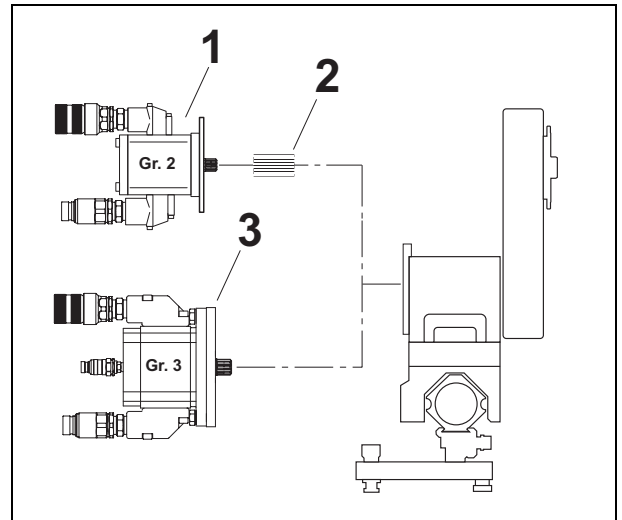

1. Saw motor size 2
2. Toothed profile coupling to size 2
3. Saw motor size 3

Connect hoses

- Push the hose coupling onto its counterpart until you hear it “click”
- Rotate the locking ring of the coupling



Ensure that the hydraulic hoses are properly coupled. Always rotate the locking ring following coupling.

5.5 Mounting V-rails on concrete

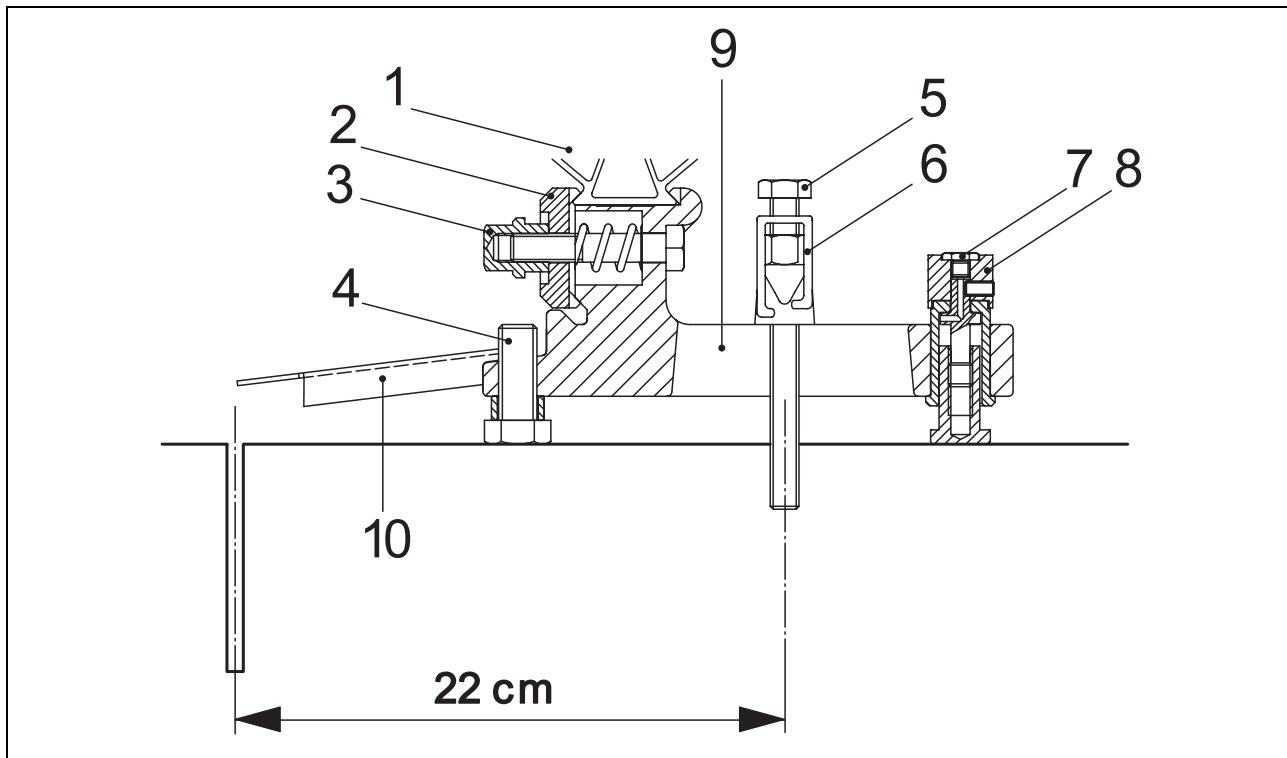

1. V-rail
2. Clamp
3. Adjusting nut
4. Adjusting screw
5. Dowel screw
6. Clamping block
7. Grease nipple
8. Adjusting foot
9. V-rail support
10. Cut guide



Please note the following:
Incorrect mounting of the rails
can endanger people during
sawing.

Use the following:

- for each dowel screw (5) the clamping blocks (6)
- steel plug: dia. 15 mm / M12
- screws (5): length = 130 mm
- **two** rail supports for the first V-rail, one rail support for each additional V-rail

Procedure

- Mark cutting line on the concrete
- Mark dowel line at a distance of 22 cm. (The same distance applies for flush cuts)
- Drill dowel hole and fit dowel according to dowel manufacturer's instructions
- Mount V-rail supports (9) on V-rails (1).

Clearance between rail supports:

- where a single rail is used, as high as possible
- where a number of rails are used, evenly distributed along the entire length of rail.

- Mount rail unit on concrete and align using cut guide (10)
- Align rail unit with adjusting foot (8), so that all adjusting feet (8) and the adjusting screws (4) are supported by the concrete.
- Tighten rail unit (1)



Once rail unit has been mounted check adjusting nut (3) and clamping block (6) anchoring

Rail limit stop

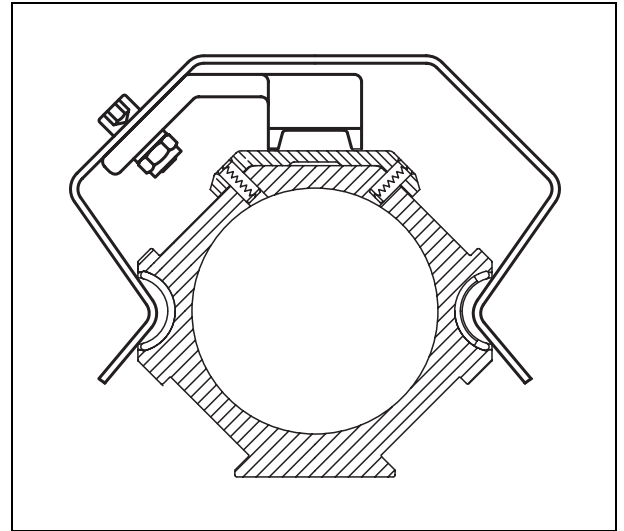

- Mount rail limit stop on the end of the rail, so that the wall saw head cannot fall off the rail.

5.6 Fitting wall saw head

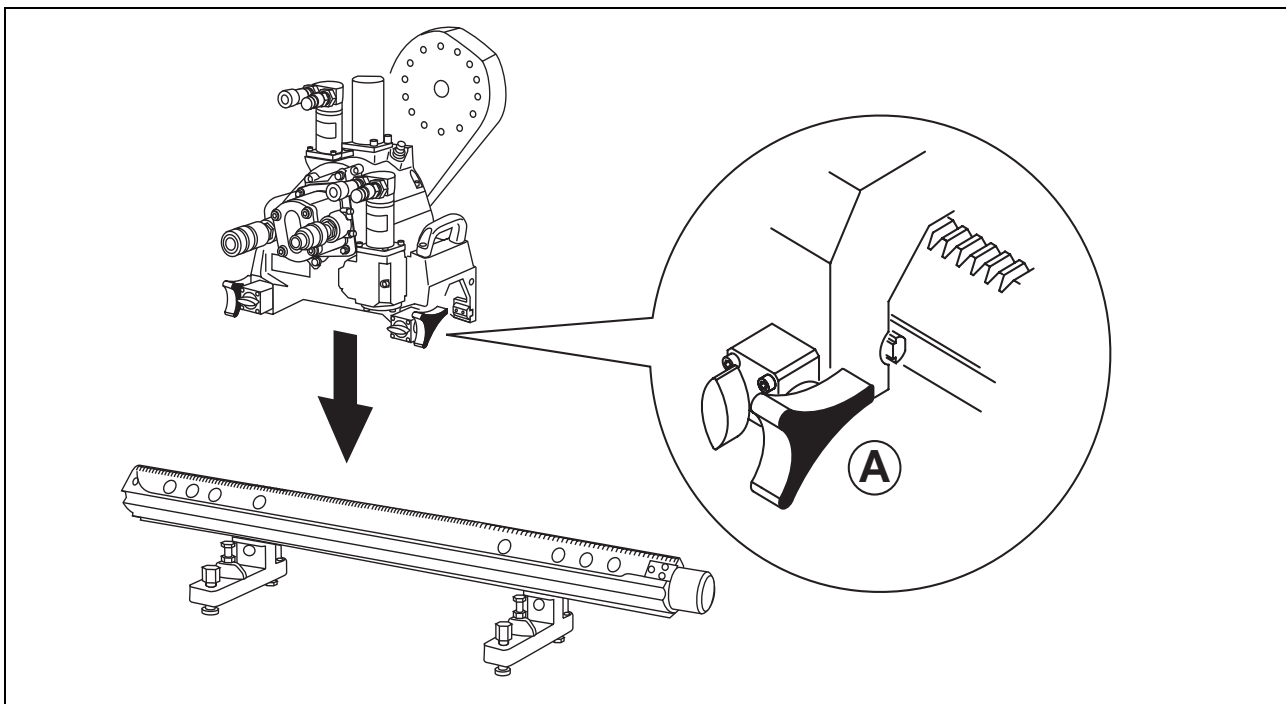

Procedure

Fit wall saw head **without** saw blade

Note position of Y-grips (A)

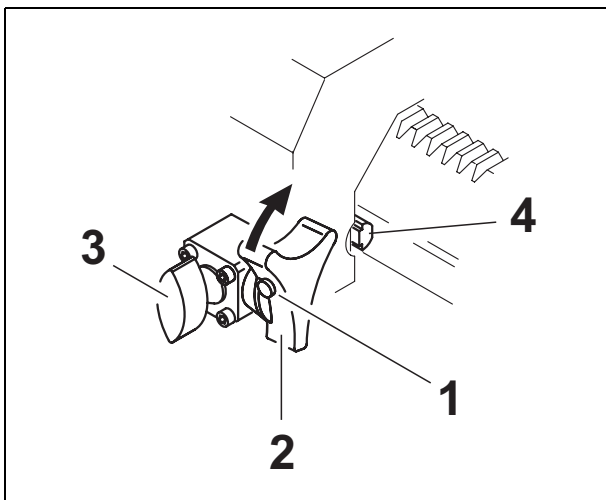

1. Twistlock

3. Feed grip

2. Y-grip

4. Guide prisms

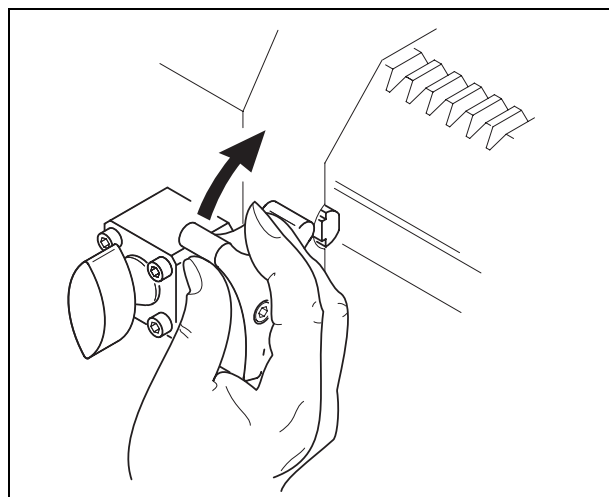

- Rotate Y-grip (2)
- Twistlock (1) latches

5.7 Adjustment / Taking up play

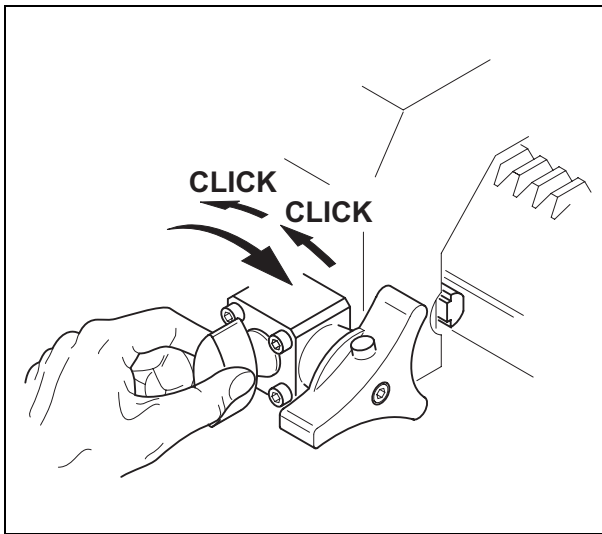

- Screw in feed grip (3) clockwise until the prism rests on the rail without any play
- Screw back by two latch positions

5.8 Removing the slide guides

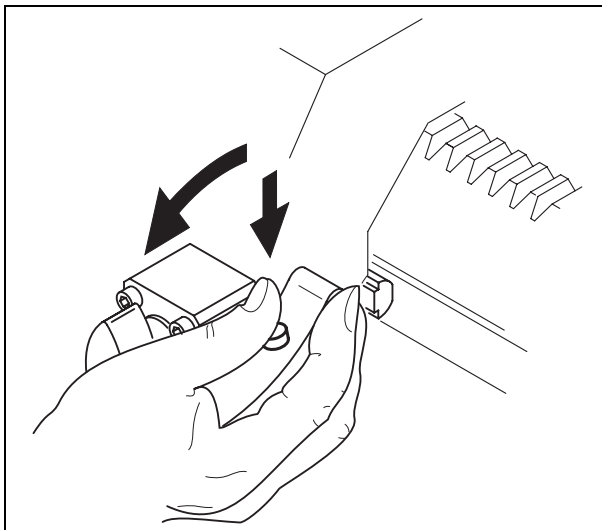

- Press on the twistlock (1) with your thumb whilst ...
- ... turning the Y-grip (2) anticlockwise

6 Saw blade unit for normal cutting



If the quick release flange is not properly secure, it may come loose and cause serious injury. It is therefore essential to closely follow the instructions below.

6.1 Saw blades of up to 1000 mm diameter

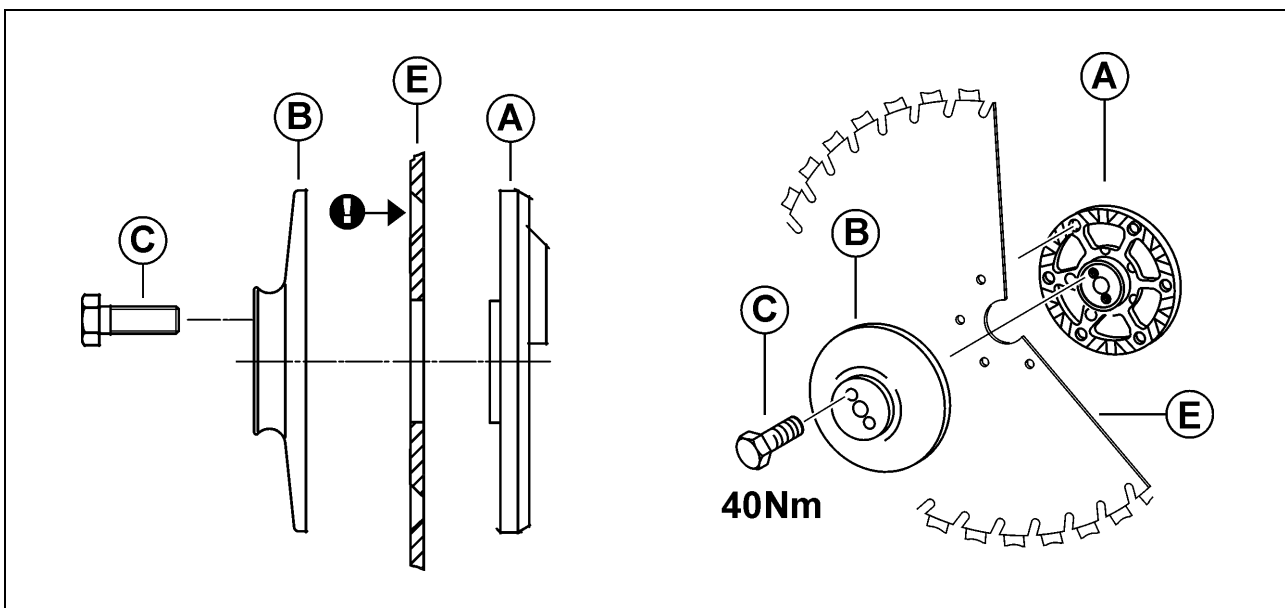

Secure saw blades of up to 1000 mm dia. with a blade cover (B) and 2 hexagon head cap screws (C)!

Assembly

- Place saw blade (E) with a 60 dia. hole on the blade flange (A)
- Saw blade alignment:
Countersinkings against blade cover (B)
- Screw down blade cover (B) with 2 hexagon head cap screws (C) onto the blade flange (A).



Use the following screws only:
Hexagon head cap screw M12x35,
order no. 969911

6.2 Saw blades over 1000 mm diameter

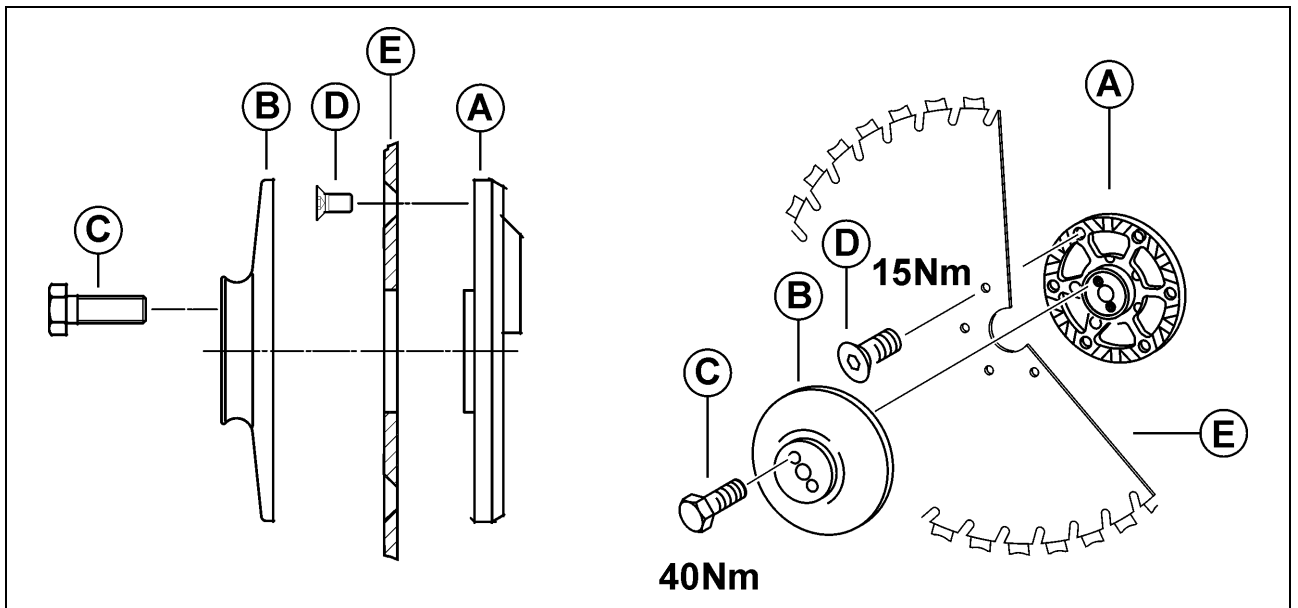

Above 1000 mm dia. saw blades must be secured with 6 countersunk head screws (D), the blade cover (B) and 2 hexagon head cap screws (C).

Assembly

- Place saw blade with a 60 dia. hole on the blade flange (A)
- Saw blade alignment:
Countersinkings against blade cover (B)
- Secure saw blade with 6 countersunk head screw (D) to blade flange (A)
(tighten screws crosswise)
- Position blade cover (B) and screw down using 2 hexagon head cap screws (C) onto the blade flange (A)



Use the following screws only:
Countersunk head screw M8x16,
grade 10.9, order No. 97182.



Use the following screws only:
Hexagon head cap screw M12x35,
order no. 969911

7 Saw blade unit for flush cutting



If the saw blade is not properly secured, it may come loose and cause serious injury. It is therefore essential to closely follow the instructions below.

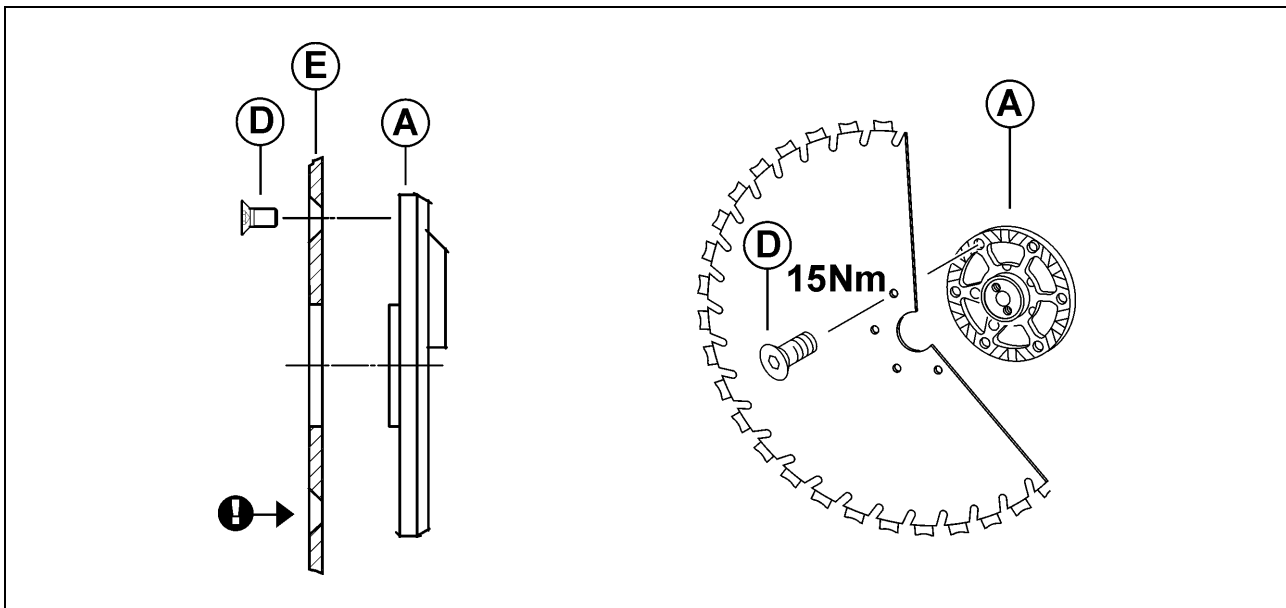

Anchor saw blades for flush cutting using 6 countersunk head screws (D).

Assembly

- Place saw blade with a 60 dia. hole on the blade flange (A)
- Note countersinking of the saw blade anchoring
- Secure saw blade with 6 Allen screws (D) to blade flange (A)
(tighten screws crosswise)



Use the following screws only:
Countersunk head screw M8x16,
grade 10.9, order No. 97182.

8 Mounting saw blade unit on wall saw

Preparation



Always switch off the drive unit and relieve the pressure in the hoses before handling the wall saw

- Pre-assemble the quick release flange and saw blade on the saw blade unit

8.1 Mount saw blade unit

The saw blade can be placed in any position.

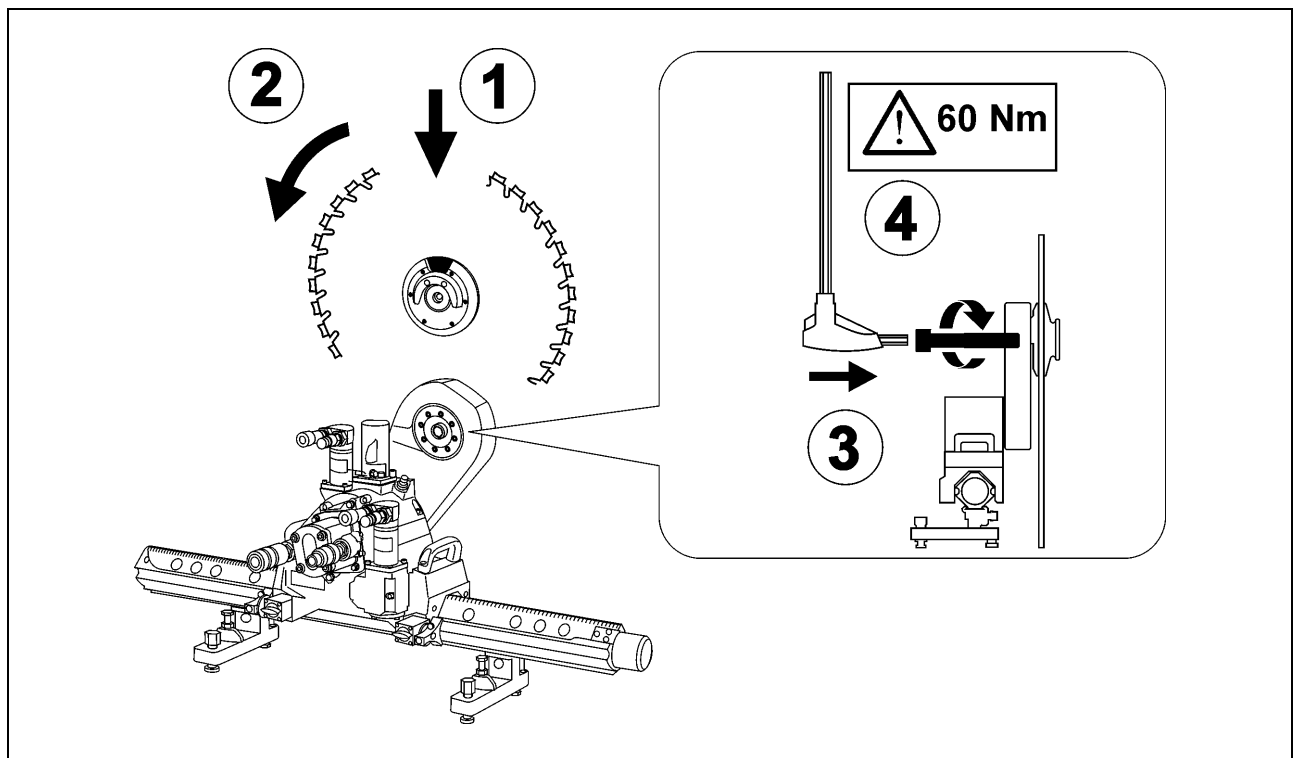

- Position saw blade unit on hub (1) and twist (2) until bolts engage
- Press central screw (3) and screw in (4) as far as the limit stop.
(Sleeve and central screw are countersunk)

9 Connecting the drive units

Fundamentals



Never connect or disconnect hoses when the drive unit is running.



If the unit is running or if the hoses are under pressure, a stationary saw blade can still suddenly rotate and seriously injure someone. It is therefore essential to closely follow the instructions below.

- Clean the couplings regularly
- Always switch off the drive unit and relieve the pressure in the hoses before handling the wall saw
- If the hoses cannot be connected easily, they are under pressure (Release pressure in the hose)

Releasing pressure in the hose

1. Hoses coupled to the drive unit
(see drive unit operating instructions)
2. Hoses that are not coupled
Put the supplied pressure relief valve on the coupling and screw it in

Connect together both ends of any hoses, which are not used, so that they are kept clean and are protected.

Connect hoses

The following hose connections must be established:

Wall sawing system	Drive unit
Saw motor	Main circuit
Swivelling motor	Feed circuit
Feed motor	Feed circuit
Water connection	Water connection

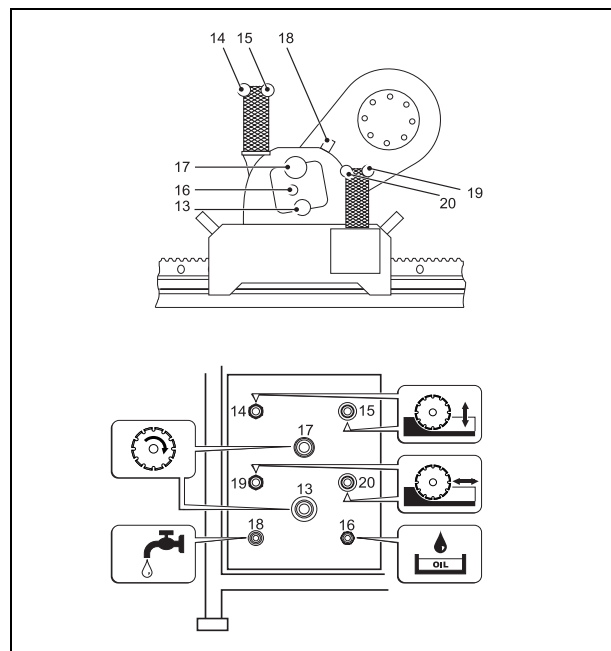

- Connect the hose couplings with the angle pieces to the wall saw head
- Connect the straight hose couplings to the drive unit
- Push the hose coupling onto its counterpart until you hear it “click”
- Twist the locking ring of the coupling

Never use force to connect the couplings



Swivel arm should only be moved if the blade flange has been fitted. Otherwise there is a risk of damage to the machine from the protruding locking sleeve.

Now check the direction of movement of the feed and swivel arm

10 Sawing

10.1 Before sawing



Never saw without the blade guard.

Follow the instructions below:

- Check direction of travel and swivelling motion
- Teeth of rails must be clean
- “Test run”: run the wall saw head along the entire length of the rail and check that the hoses do not catch at any point
- Cover sharp-edged objects
- Check that all dowel screws on the rail supports have been tightened
- Check if water is emerging at the point of rotation of the saw blade

10.2 The first cut (precut)

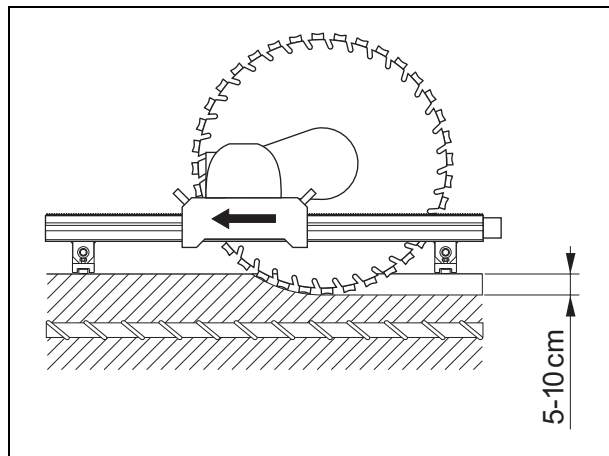

Procedure

Note:

- if possible do not cut through any reinforcements
- swivel arm pulled
- cutting depth 5-10 cm
- working pressure 100-120 bar

- Move wall saw head to starting position
- Sawing

10.3 After the first cut

Feed after the first cut

After the first cut more than 5-10 cm can be fed. The possible cutting depth is dependent upon the amount of reinforcement and the aggregates in the concrete and the size and specification of the blade.

The optimum cutting depth can be between 7 and 12 cm.

Cutting through reinforcements

For cuts following the length of the reinforcement:

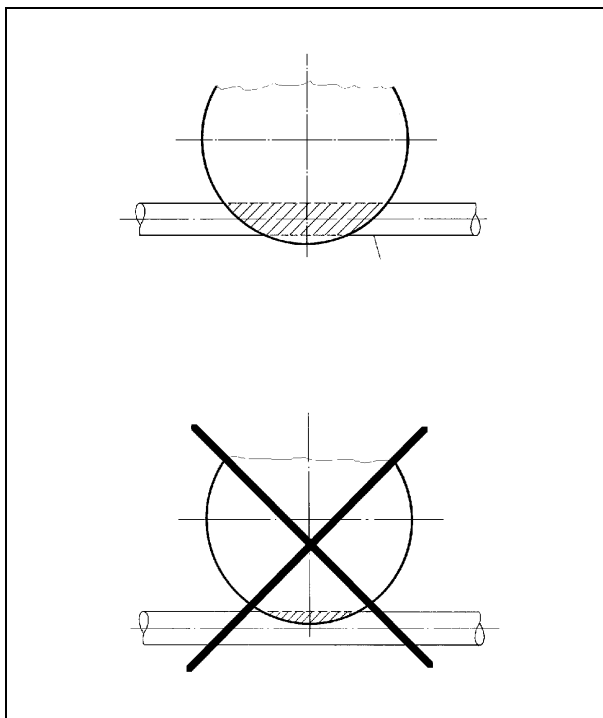

- Prepare the cut so that the reinforcement is completely cut through.
- Do not plan the cut along the reinforcement. The cut would otherwise drift.

In sections where there are no reinforcing rods do not use high power cutting, but reduce this by about 40 bars. If the blade touches any reinforcing rods, the pressure will not then increase above the maximum permitted level.

Always withdraw from a cut with the saw blade running.

If the saw blade jams

- Carefully withdraw from the cut with a travelling or swivelling motion.
- If this does not work: Disassemble saw blade from wall saw head and remove saw blade alone from the cut.

At the end of the cut

- Withdraw from the cut with the saw blade running
- Move swivel arm to the uppermost position

10.4 Terminating the work

- Clean wall sawing system, e.g. by spraying with water



Always switch off the drive unit and relieve the pressure in the hoses before handling the wall saw

Uncoupling hoses

- Switch off drive unit and relieve the pressure in the hoses
- Rotate locking ring to release position
- Hold hose end straight
- Slide back coupling sleeve
- Pull off hose
- Couple hoses together to avoid soiling and damage

11 Disassembling saw blade unit



Always switch off the drive unit and relieve the pressure in the hoses before handling the wall saw

Correctly disassemble saw blade

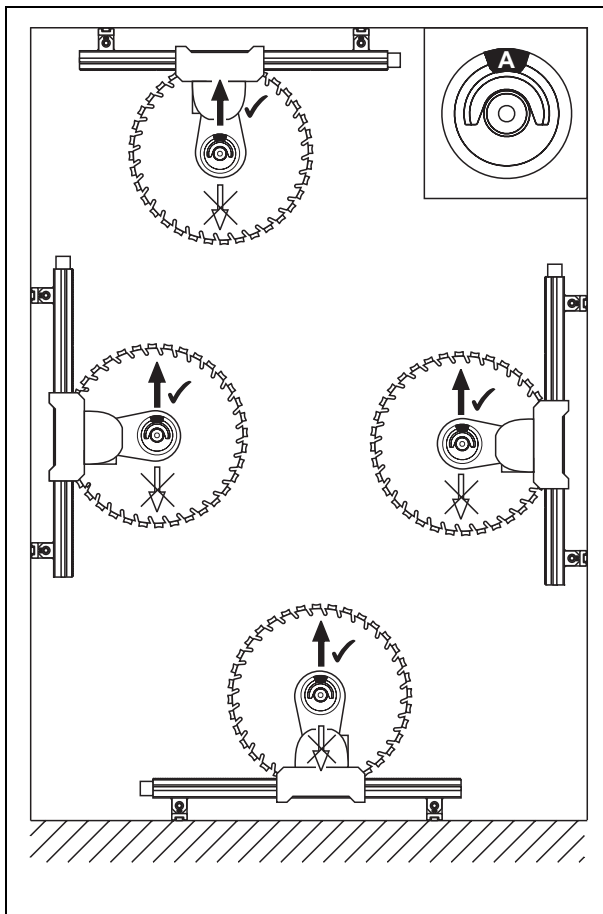

- Turn marking (A) on the blade flange to the safe removal position.
(In the wrong position the saw blade may come lose and drop off)

Only when the marking (A) of the blade flange is in the correct position can the saw blade be correctly removed from the wall saw.

Loosening central screw

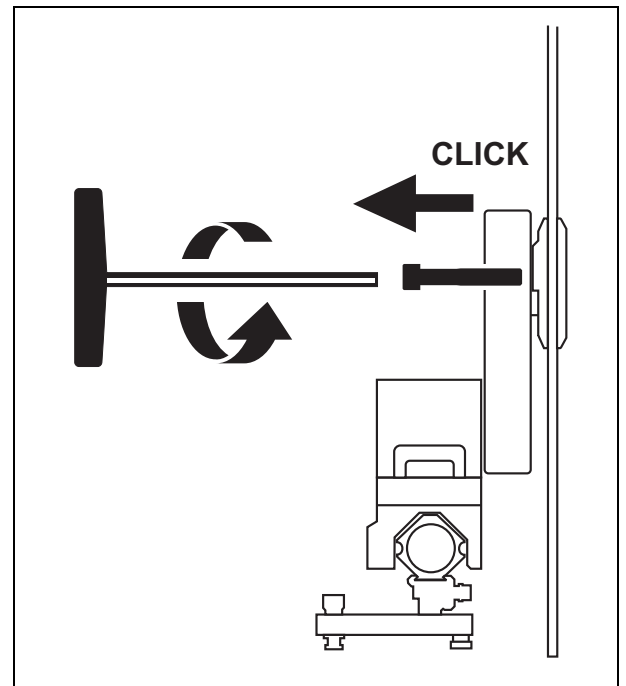

- Fully loosen central screw

The central screw has been correctly loosened if a "click" is heard and the central screw pops out by a few millimetres.

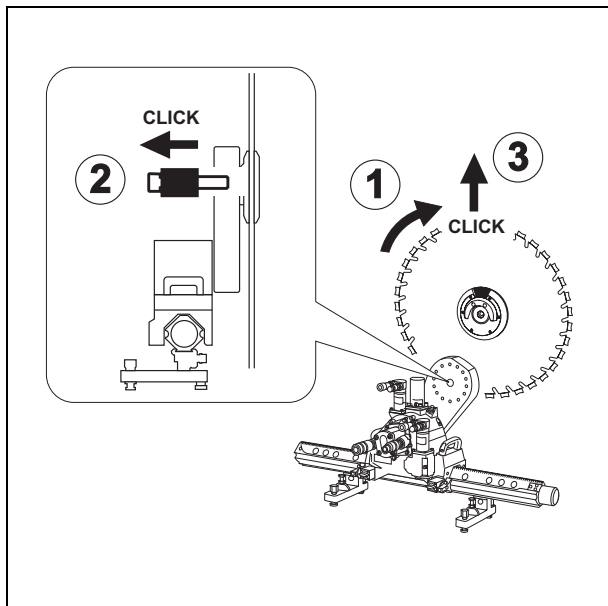
Loosen locking sleeve

- Rotate saw blade (1), until the locking sleeve pops out a few millimetres with a "click" (2)

The locking sleeve has been correctly loosened if a "click" is heard and the locking sleeve pops out by a few millimetres.

The saw blade unit can only be disassembled if the locking sleeve has popped out by a few millimetres.

- Disassemble the saw blade unit (3)

12 Troubleshooting

Proceed systematically when looking for the cause of a fault. In doing so also refer to the operating instructions for the electric motor and control unit(s).

If you cannot find the defect or eliminate the faulty condition, please contact our after-sales service.

Before calling us, please note the following:

- The more accurately you describe the fault, the better we can help you.
- Have the operating instructions close to hand.
- Note down the serial number of your equipment.

Fault	Possible cause	Solution
Wall saw head does not move or only moves jerkily on the rail	Slide guide tightened too hard	Loosen slide guide slightly so that slide (without sawing) starts to move at 20 bar
	Rail tootinging soiled	Clean rail
	Prisms worn	Exchange prisms
	Guiding groove of rail warped	Replace rail
	Misaligned rail joint	Use rail lock
	Wrong or defective feed motor	Exchange motor
	Defective feed gears	Exchange feed gears, contact HYDROSTRESS after sales service
	Hoses incorrectly coupled	See "Coupling hoses"
	Defective drive unit	Check drive unit
Swivel arm does not move or only moves jerkily	Wrong or defective feed motor	Exchange motor
	Defective swivel gears	Exchange swivel gears, contact HYDROSTRESS after sales service
	Hoses incorrectly coupled	See "Coupling hoses"
	Defective drive unit	Check drive unit

Fault	Possible cause	Solution
Main pressure fluctuates wildly	Speed too low	Mount correct saw motor according to motor table
	Saw motor worn out	Exchange motor
	Defective drive unit	Check drive unit
	Wrong or defective feed motor	Exchange motor
Blade does not rotate when main circuit is switched on	Saw blade jams	Lift saw blade from cut slightly
	Defective drive unit	Check drive unit
	For safety reasons the main shaft of the wall saw head is immobilised if no blade seat flange is mounted on the hub	Mount saw blade correctly with blade seat flange on the hub
	Incorrectly coupled	Check couplings
Saw motor heavily fouled by oil	Defective saw motor shaft sealing ring	Exchange shaft sealing ring
	Motor size 3 leak oil connection incorrectly coupled	Couple leak oil connection correctly
	Leaky seals or couplings (FD)	Exchange seals or couplings, contact HYDROSTRESS after sales service
Coupling leaks	Defective seal	Replace seal
	Defective coupling	Replace coupling
No water on saw blade	Water valve shut off	Open water valve.
	Water hose incorrectly coupled	Couple water hose, locking ring must slide forwards
	Water pressure too low	Water pressure: min. 1 bar
	Water supply interrupted	Check the water supply
	Pipes frozen	Thaw pipes, contact HYDROSTRESS after sales service
	Defective seal between shaft and blade hub	Exchange seal, contact HYDROSTRESS after sales service
Sawing power is inadequate, despite correctly selected saw motor	Defective saw motor	Replace saw motor
	Defective feed motor	Replace feed motor
	Defective drive unit	Check drive unit

13 Maintenance

13.1 Maintenance table

Service the system within the indicated intervals in order to ensure:

- Safety for the operator
- Optimum performance
- Optimum reliability at all times



Uncouple wall sawing system prior to performing maintenance work on the unit

Maintenance interval	Action	Remarks
after first 50 h	Toothed wheel swivel arm oil change	Fill with 1 dl oil
weekly	Check prism guides for wear	Replace, before anchoring screws of prisms touch the rail
weekly	Check couplings for - leaks - damage	Replace leaky or damaged couplings
weekly	Grease Y-slide guides grease nipple	2-3 grease injections
weekly	Check water couplings for - leaks - damage	Replace leaky or damaged couplings
annually	Change bearing housing grease	Fill with 600 g gear grease
annually	Major service	Must only be performed by HYDROSTRESS or a HYDROSTRESS authorised representative
every 50 h	Toothed wheel swivel arm oil change	Fill with 1 dl oil

Correct maintenance procedures are described on the following pages.

13.2 Change prism guides

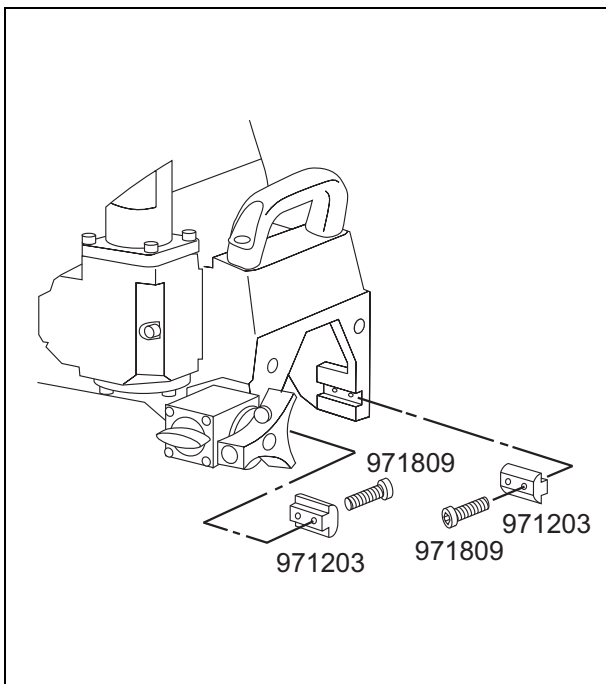

13.4 Exchange swivelling motor

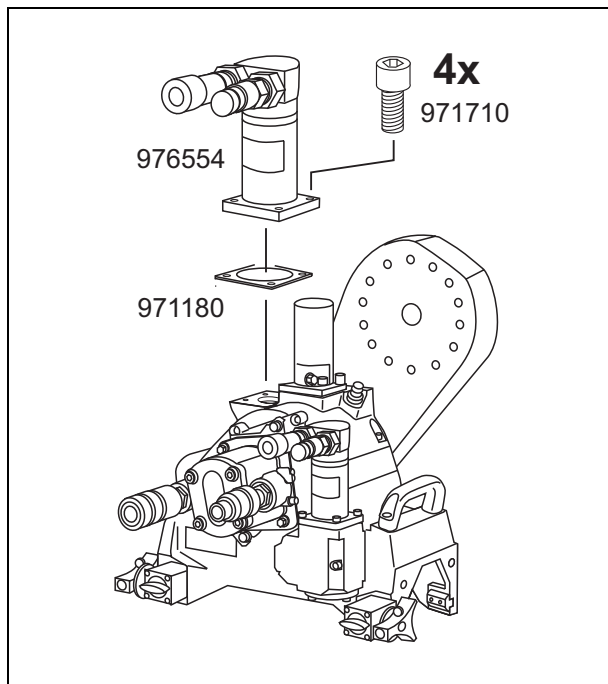

13.3 Change feed motor

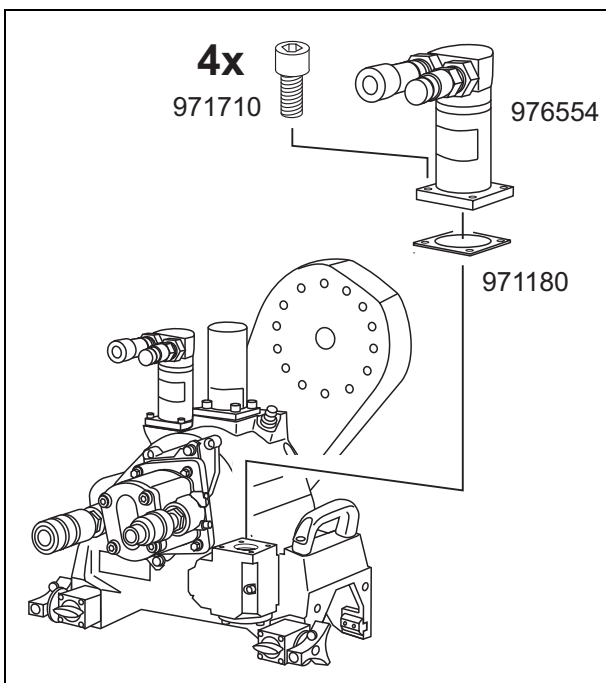

Use the following screws only:
Cylindrical screw M6x20, grade 12.9, order no. 971710

Use the following screws only:
Cylindrical screw M6x20, grade 12.9, order no. 971710

13.5 Change gear grease

Use only grease with penetration rate 420-460 NLGI code: 00.

Feed gears

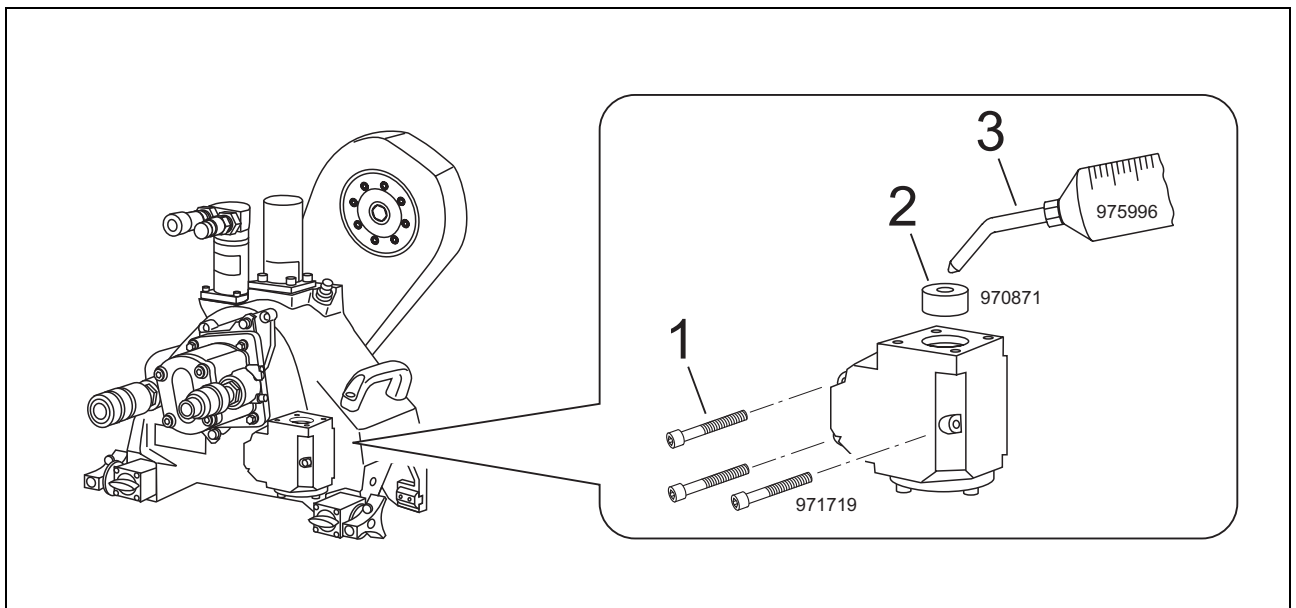

- Disassemble feed motor
- Disassemble feed gears
Remove 3 Allen screws (1) M6x55 / 971719
- Fit support foot (2) 970871
- Fill with 100 g grease using grease gun (3) 975996
(old grease is forced out by the new grease)
- Mount feed gears
- Mount feed motor with paper seal

Bearing housing

- Remove blade guard seat
- Stand wall saw on its head
- Empty out old gear grease
- Fill with 600 g gear grease via the opening in the blade guard quick acting closure
- Fully remount blade guard seat.

13.6 Repair

Components other than those described may only be replaced by authorized personnel trained at HYDROSTRESS.

After consultation with HYDROSTRESS or an authorized HYDROSTRESS representative, components may also be replaced by qualified personnel without HYDROSTRESS training.

14 Transport, taking out of service, storage, disposal

14.1 Transport

The wall sawing system is a high-tech product. Protect it against transport damage:

- Disassemble blade guard
- Do not place any parts against or on the wall sawing system, the blade guard or the rail system
- Protect the tothing of the rail system from impacts



Handle the wall sawing system with care and if possible using two people, in order to avoid back injuries and accidents.

14.2 Taking out of service and storage

The wall sawing system consists partially of material that can corrode. If you take the unit out of service for some time do the following:

- Blow the water out of the water line
- Coat the rail system with oil
- Store in a dry location

14.3 Disposal

The wall sawing system comprises the following materials:

- Aluminium casting
- Rolled aluminium products
- Bronze
- Steel
- Rubber
- Rubber / nylon fabric
- Synthetic lubricant
- Plexiglass

Acquaint yourself with the local regulations for disposal in your country.

15 Accessories

15.1 Accessories available to order

V-rails VAS 1100mm steel	974400
V-rails VAS 1400mm steel	974402
V-rails VAS 1800mm steel	974404
V-rails VAS 2200mm steel	974406
Limit stop complete for rail VAS	963698
V-rail support steel	974478
V-stair rail support	974487
V-swivel rail support	961983
Rail connector	977523
Blade guard 3-part 800mm alu	999180
Blade guard 3-part 800mm alu flush	999212
Blade guard 3-part 1000mm alu	984240
Blade guard 3-part 1000mm alu flush	999160
Blade guard 3-part 1200mm alu	962755
Blade guard 3-part 1200mm alu flush	999156
Blade guard 2-part 1380mm	977618
Blade guard 2-part 1600mm	977606
Blade guard 2-part 2200mm	976184
Leak oil hose 8m FIRG	974066
Pressure relief device FD	977495
Dowel gauge	977609
Dowel HKD M12	971622
Dowel drill dia. 15mm	977180
Dowel iron HKD M12	977153
Anchoring block for concrete	974476
Suction lifter	999980
Multiple blade holder	962805
Blade spacing ring 28mm	971298
Support foot	970871
Quick release flange	999146
Blade flange	999050
Blade cover	999756
Tool box	10977019
Suction lifter	999980

15.2 Hydraulic drive motors

Hydraulic drive motor size 2 (excluding quick change set)

Saw motors 8ccm / FD	976158
Saw motors 12ccm / FD	976034
Saw motors 16ccm / FD	976160
Saw motors 18ccm / FD	976161
Saw motors 22ccm / FD	976162
Saw motors 26ccm / FD	976523
Saw motors 30ccm / FD	976163
Quick change set	973892

Hydraulic drive motor size 3 (incl. quick change set)

Saw motors 20ccm / FD	976164
Saw motors 25ccm / FD	976165
Saw motors 31ccm / FD	976166
Saw motors 40ccm / FD	976167
Saw motors 50ccm / FD	976168
Quick change set motors size 3	976133

Hydraulic feed motor

Feed motor	976164
------------	--------

16 Spare parts list

16.1 Ordering information

For spare part orders we need the following information:

- Machine type and index according to type plate
(e.g. FZ-4S, Index 000)
- Number of machine according to type plate
(e.g. 51886)
- Spare part number as per spare parts list
(e.g. 08W7-75648-02)

For orders, enquiries and information, please refer to your appropriate branch office.

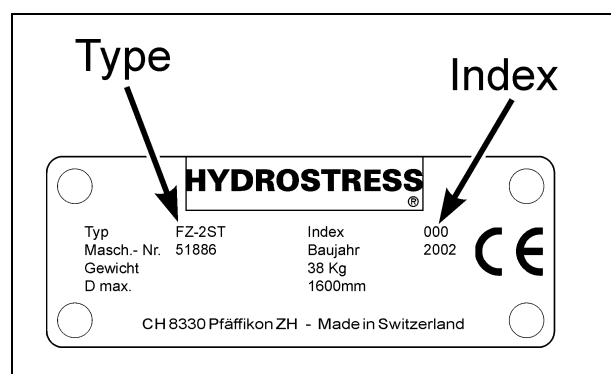

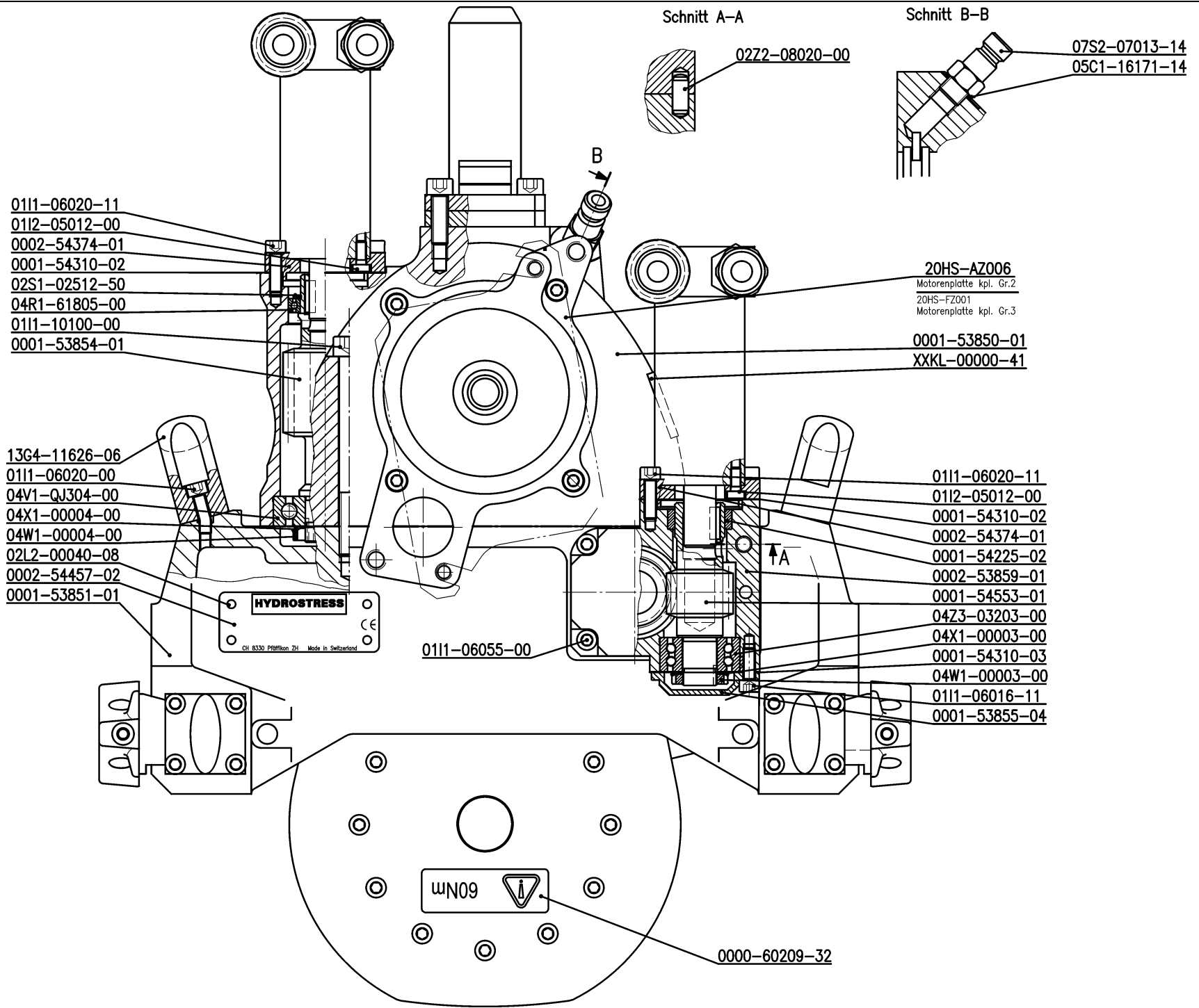

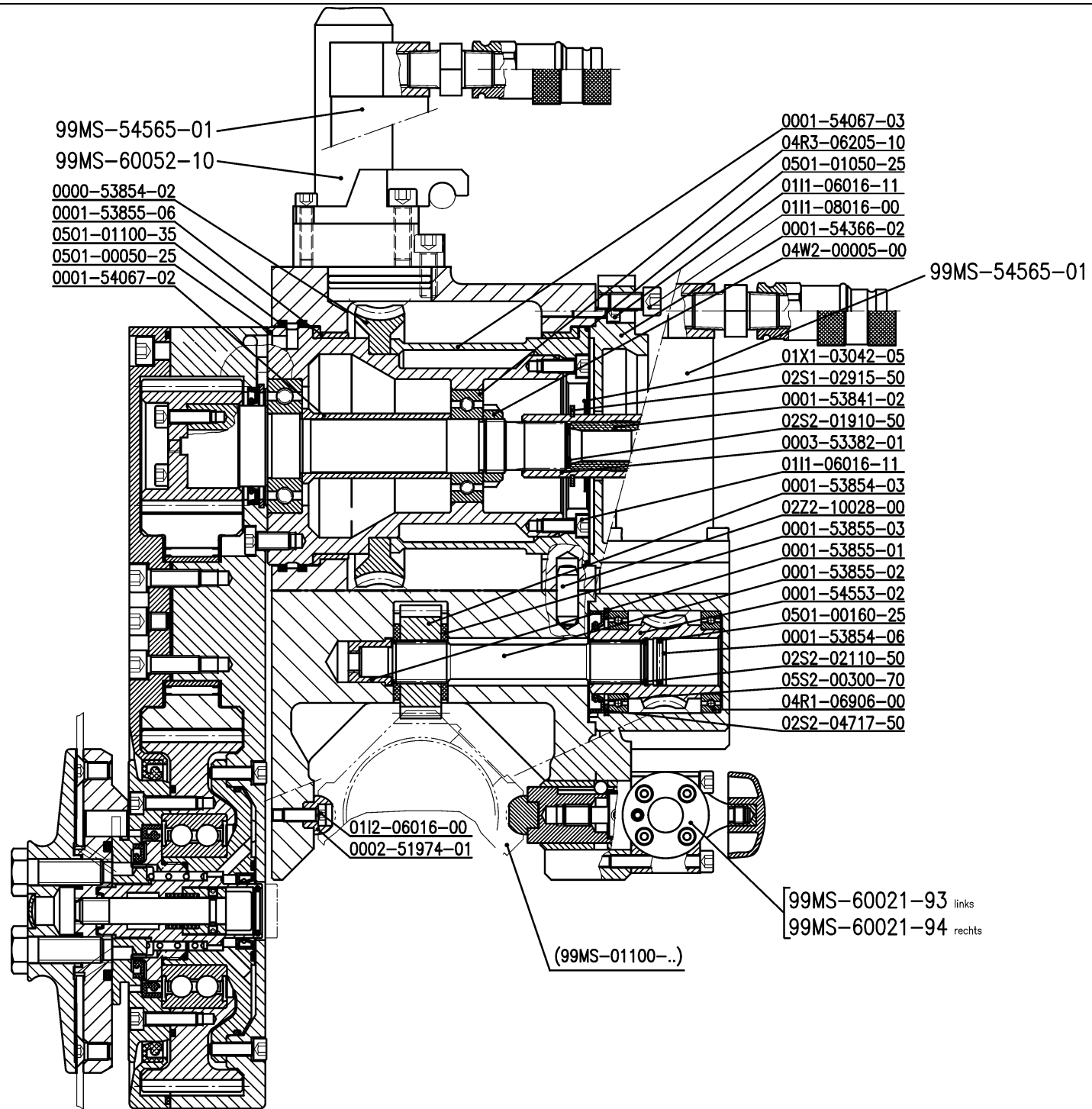

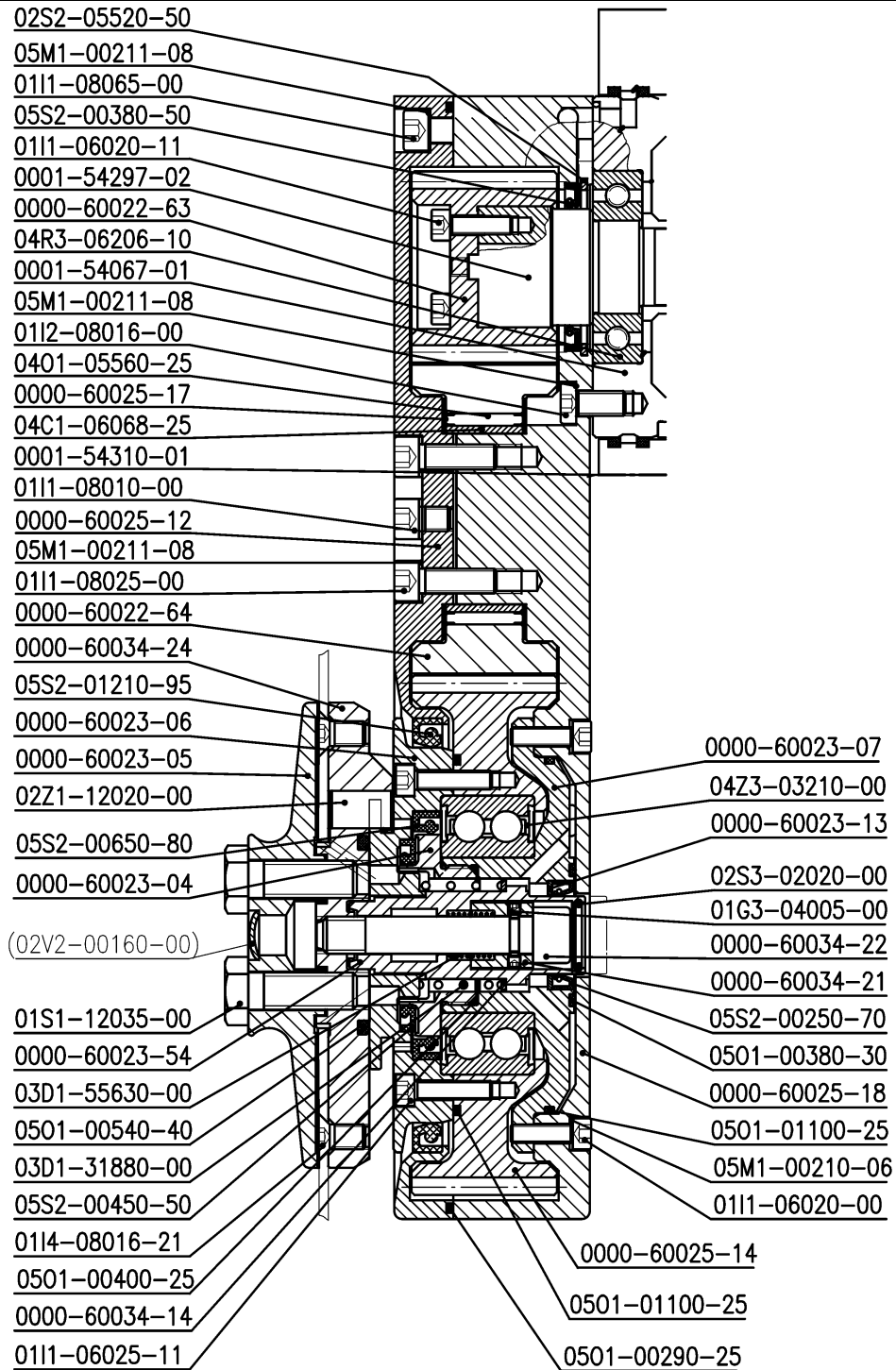

Ansicht A

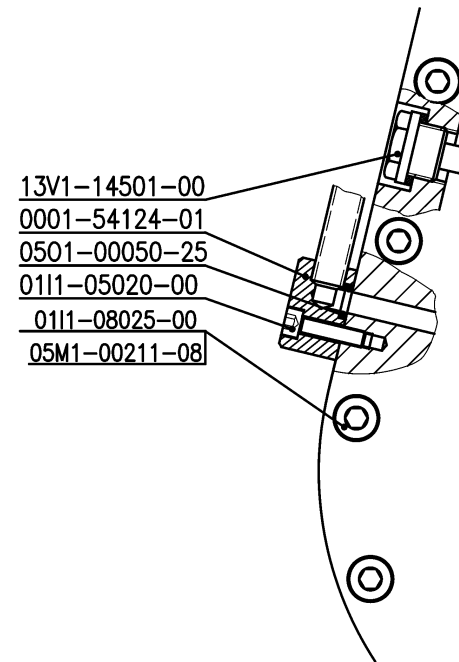

MSWA-FZ-4S	999039	Wandsäge FZ-4S	Scie murale FZ-4S	Wall saw FZ-4S	Sega a muro FZ-4S	pcs.
20HS-AZ006	973892	Schnellwechselsatz AZ/FZ	Quick-change set FZ/DZ/AZ	Plaque changement rapide	KIT CAMBIO RAPIDO MOTORE	1
99MS-60021-93	963548	Y-Schlittenf. R Bronze	Y-track guide right	Y-Schlittenf. R Bronze	Y-Schlittenf. R Bronze	1
99MS-60021-94	963547	Y-Schlittenf. L Bronze	Y-track guide left	Y-Schlittenf. L Bronze	Y-Schlittenf. L Bronze	1
99MS-54565-01	976554	Vorschubmotor DZ/FZ	Feed motor hydr.DZ/FZ	Moteur d'avance DZ/FZ	MOTORE AVANZ.PICC. 32 oml	2
99MS-60052-10	968764	Blattschutzaufn. US kpl.	Bolt (US version)	Blattschutzaufn. US kpl.	Blattschutzaufn. US kpl.	1
99MS-54653-01	976997	Vorschubgetr. 1:16 DZ/FZ	Feed drive 1:16 DZ/FZ	REDUCTEUR AVANCE 1/16 DZ/	RIDUTTORE AVANZ.1:16 DZ/FZ	1
0000-60022-63	969586	Antriebsritzel FZ-3S Z=22	Drive pinion Z22	Antriebsritzel Z 22	PIGNONE DI TRAZIONE Z22	1
0000-60022-64	969587	Zwischenrad FZ-3S Z=42	Intermediate wheel Z=42	Poulie intermédiaire	RUOTA INTERMEDIA Z42	1
0000-60023-04	984886	Nabenmutter	Nabenmutter	Nabenmutter	Nabenmutter	1
0000-60023-05	984759	Blattdeckel	Blattdeckel	Blattdeckel	Blattdeckel	1
0000-60023-06	984761	Blattnabe	Blattnabe	Blattnabe	Blattnabe	1
0000-60023-07	984762	Nabenlager	Nabenlager	Nabenlager	Nabenlager	1
0000-60023-13	984983	Scheibe	Scheibe	Scheibe	Scheibe	1
0000-60023-54	10977476	Spannhülse	Spannhülse	Spannhülse	Spannhülse	1
0000-60025-12	963655	Deckel FZ-3S	cover	Deckel	COPERCHIO FZ-3S	1
0000-60025-14	963652	Nabenritzel FZ-3S Z=65	Hub pinion z65	Moyeu de pignon	PIGNONE DEL MOZZO FZ-3S	1
0000-60025-17	964876	Lagerscheibe	Bearing disk	Rondelle roulement	RONDELLA CUSCINETTO FZ-3S	2
0000-60025-18	984903	Gehäuse	Gehäuse	Gehäuse	Gehäuse	1
0000-60034-14	10977178	Federring	Federring	Federring	Federring	1
0000-60034-21	10977473	Nabenring	Nabenring	Nabenring	Nabenring	1
0000-60034-22	10977474	Zylinderschraube M12x70	Zylinderschraube M12x70	Zylinderschraube M12x70	Zylinderschraube M12x70	1
0000-60034-24	10977478	Blattaufnahme	Blattaufnahme	Blattaufnahme	Blattaufnahme	1
0000-60059-09	977609	Dübellehre	Rawlplug template	Gabarit de tamponnage	Dübellehre	1
0001-53841-02	971060	Zahnhülse FZ/RZ (Bosch)	Tooth profile coupling	Douille cannelée FZ/RZ	GIUNTO A PROFILO DENTATO	1
0001-53850-01	971057	Lagergehäuse FZ	Bearing housing FZ	Carter pour rlt. FZ	Lagergehäuse FZ	1
0001-53851-01	971061	Support FZ	Support FZ	Support FZ	SUPPORTO BASE FZ/S	1
0001-53854-01	971064	Schnecke SV	Worm SV	VIS SANS FIN SV DZ	VITE SENZA FINE BRAC. DZ/	1
0001-53854-02	971065	Schneckenrad SV	Worm SV	ROUE DE VIS SANS FIN SV D	RUOTA ELICOID. INTERNA DZ	1
0001-53854-03	974755	Vorschubrad	Feed wheel	PIGNON D'AVANCE DZ	RUOTA DENTATA AVANZ. DZ	1
0001-53854-06	971066	Dichtungsscheibe	Sealing	Garniture	Guarnizione	1
0001-53855-01	974757	Lagerhülse DZ/FZ	Storage sleeve DZ/FZ	Douille DZ/FZ	BUSSOLA ALBERO AVANZ DZ/F	1
0001-53855-02	971069	Vorschubwelle DZ/FZ	Feeding shaft DZ	Arbre d'avance DZ/FZ	ALBERINO AVANZ. DZ	1
0001-53855-03	971070	Lauftring DZ/FZ	Ring DZ/FZ	Anneau DZ/FZ	ANELLO TEFLON ALBER. DZ/F	2
0001-53855-06	971071	Lagerbüchse DZ/FZ	Bearing bush DZ/FZ	Coussinet DZ/FZ	BOSSOLO PER SUPP. DZ/FZ	2
0001-54067-01	974771	Lagerhülse DZ/FZ	Storage sleeve DZ/FZ	ENTRETOISE DZ	MANICOTTO DZ FZ	1
0001-54067-02	974772	Distanzrohr DZ/FZ	Distance bush DZ/FZ	ENTRETOISE TETE DE SCIE D	BUSSOLE DISTANZIATORE DZ	1
0001-54067-03	971105	Spannhülse DZ/FZ	Tensioning bush DZ/FZ	DOUILLE DE SERRAGE DZ/FZ	BUSSOLA DI SERRAGGIO DZ/F	1
0001-54124-01	971118	Wasserleitung DZ/FZ	Water hose DZ/FZ	CANALISATION EAU DZ	TUBO ACQUA PORTATA	1

	MSWA-FZ-4S	999039	Wandsäge FZ-4S	Scie murale FZ-4S	Wall saw FZ-4S	Sega a muro FZ-4S	pcs.
	0001-54297-02	974784	Antriebswelle FZ	Driving shaft FZ	ARBRE DE COMMANDE FZ	ALBERO MOTORE FZ	1
	0001-54310-01	971179	Dichtung Lagergehäuse	seal, bearing housing	JOINT DE PALLIER	GUARNIZIONE TESTA FZ	1
	0001-54366-02	975878	Aufnahmeplatte FZ/RZ Gr2+3	Flange FZ/RZ	BRIDE DE MOTEUR FZ/RZ	FLANGIA FISSAG. MOTORE F	1
	0002-51974-01	971203	Prisma Bronze	Guiding device (prism)	Glissoir en bronze	PRISMA AZ/FZ/DZ in ottone	2
	0002-54457-02	975924	HS-Typenschild klein	HS name plate small	HS-Petite plaque	HS-Typenschild klein	1
	0003-53382-01	971529	Zahnhülse zu RZ/FZ	Tooth profile	FOURREAU CANNELE INT RZ/F	GIUNTO A PROFILO DENTATO	1
	01G3-04005-00	10977484	Gewindestift M4x5	Gewindestift M4x5	Gewindestift M4x5	Gewindestift M4x5	2
	0111-05020-00	971693	Inbus-Schraube M 5x 20	Allen screw M5 x 20	Vis CHC M5x20	VITE BRUGOLA M5X20 DZ	2
	0111-06016-11	971706	Inbus-Schraube M6x16 12.9	Allen screw M6x16	Vis CHC M6x16 12.9	VITE BRUGOLA M6X16 12,9	12
	0111-06016-11	971706	Inbus-Schraube M6x16 12.9	Allen screw M6x16	Vis CHC M6x16 12.9	VITE BRUGOLA M6X16 12,9	4
	0111-06020-00	971709	Inbus-Schraube M 6x 20	Socket screw M 6x 20	Vis CHC M6x20	VITE BRUGOLA M6X20	4
	0111-06020-00	971709	Inbus-Schraube M 6x 20	Socket screw M 6x 20	Vis CHC M6x20	VITE BRUGOLA M6X20	12
	0111-06020-11	971710	Inbus-Schraube M6x20 12.9	Al. head screw M6x20 12.9	Vis CHC M6x20 12.9	VITE BRUGOLA M6X20 12,9	4
	0111-06025-11	971711	Inbus-Schraube M 6x 25	Allen screw	Vis CHC M6x25	VITE BRUGOLA M6X25	12
	0111-08010-00	971728	Inbus-Schraube M 8x 10	Socket screw M 8x 10	Vis CHC M8x10	Inbus-Schraube M 8x 10	1
	0111-08016-00	971731	Inbus-Schraube M 8x 16	Socket screw M 8x 16	VIS CHC M 8X16 95	VITE BRUGOLA M8X16	2
	0111-08020-11	971735	Inbus-Schraube M8x20 12.9	Al. head screw M8x20 12.9	VIS CHC M8 X 20 12,9 95	VITE BRUGOLA M8X20 12.9	6
	0111-08025-00	979284	Inbus-Schraube M8 x 25	Socket screw M 8x 25	Vis CHC M8x25	VITE M 8x 25	16
	0111-08065-00	971750	Inbus-Schraube M 8x 65	Socket screw M 8x 65	0 Vis CHC M 8x 65	VITE M8 x 65	8
	0111-10100-00	971774	Inbus-Schraube M10x100	Socket screw M10x100	Vis CHC M10x100	Inbus-Schraube M10x100	4
	0112-06016-00	971809	Inb-Schr.nied.Kopfm 6x 16	Allen screw M 6x 16	Vis HC tête basse M6x16	VITE BRUG. M6X16 PRISMA D	4
	0112-08016-00	979293	Inb-Schr.nied.Kopfm 8 x16	allen screw filhd M 8 x16	Vis HC tête basse M8 x16	VITE M 8 x16 BASSA	4
	0114-08016-21	971825	Senkkopfschraube M 8x 16	Countersunk screw M8x16	Vis tête fraisée M8x16	VITE T. SVASATA M8X16	6
	01S1-12035-00	969911	6kt. Schraube M12x35	hex. screw M12x35	6kt. Schraube M12x35	6kt. Schraube M12x35	2
	01X1-03042-05	976423	Distanzscheibe 30/42/0,5	Distance washer30/42/0,5	Distanzscheibe 30/42/0,5	Distanzscheibe 30/42/0,5	1
	02L2-00040-08	971986	Kerbnagel 4x8	Wedge nail 4x8	Rivet 4x8	VITE M4x8 X LIVELLA	4
	02S1-02512-50	971996	Seegering Welle Dm 25	seeger ring shaft dia 25	CIRCLIPS ARBRE DIAMETRE 2	SEEGER DM 25 DZ/FZ	1
	02S2-05520-50	965589	Seegering Bohr. Dm 55	Seege ring dm 55	Seegering Bohr. Dm55	SEEGER	1
	02S3-02020-00	999679	Sprengring Dm20 Bohrung	Sprengring Dm20 Bohrung	Sprengring Dm20 Bohrung	Sprengring Dm20 Bohrung	1
	02V2-00160-00	999483	Verschluss Scheibe d=16	Verschluss Scheibe d=16	Verschluss Scheibe d=16	Verschluss Scheibe d=16	1
	02Z1-12020-00	984930	Zylinderstift Dm12x20	Zylinderstift Dm12x20	Zylinderstift Dm12x20	Zylinderstift Dm12x20	2
	02Z2-08020-00	972055	Zylinderstift 8 m6 x 20	Straight pin	GOUPILLE 8m6x20	SPINA DZ/FZ	1
	02Z2-10028-00	972057	Zylinderstift 10 m6 x 28	straight pin 10 m6 x 28	Goupille 10 m6x28	SPINA 10 m6 x 28	2
	03D1-31505-00	999283	Druckfeder Dm16x1.25	Druckfeder Dm16x1.25	Druckfeder Dm16x1.25	Druckfeder Dm16x1.25	1
	03D1-31855-00	984112	Druckfeder Dm 25x2.5 L=49	Druckfeder Dm 25x2.5 L=49	Druckfeder Dm 25x2.5 L=49	Druckfeder Dm 25x2.5 L=49	1
	03D1-55630-00	10977472	Druckfeder Dm 13,5 / 0,9x56,7	Druckfeder Dm 13,5 / 0,9x56,7	Druckfeder Dm 13,5 / 0,9x56,7	Druckfeder Dm 13,5 / 0,9x56,7	1
	04C1-06068-25	963378	Nadelkranz K60x68x25	Needlecollar K60x68x25	Roulement aiguil 60x68x25	CORONA A RULLI K60x68x25	1
	04O1-05560-25	963379	Innenring IR 55x60x25	Inner ring IR 55x60x25	Innenring IR 55x60x25	ANELLO INTERNO 55x60x25	1
	04R1-61805-00	972143	Rillen-Kugellag. 61805T	ball bear. 61805T	ROULEMENT A BILLE 61805 T	CUSCINETTO 61805 T	1
	04R3-06205-10	977061	Ril.Kugell. 6205-2RS1-W64	Deep groove ball bearing	Roulement billes 6205-2RS	CUSCINETTO 6205 KW 10	1
	04R3-06206-10	977062	Ril.Kugell. 6206-2RS1-W64	Deep groove ball bearing	Roulement billes 6206-2RS	CUSCINETTO 6206 KW 10	1

MSWA-FZ-4S	999039	Wandsäge FZ-4S	Scie murale FZ-4S	Wall saw FZ-4S	Sega a muro FZ-4S	pcs.
04V1-QJ304-00	972157	Vierpunktlager QJ304	Four point bearing	PALIER 4 POINTS QJ304	CUSCINETTO QJ304	1
04W1-00004-00	974848	Wellenmutter KM4	Shaft nut	ECROU KM4	DADO ALBERO 14 DENTI AZ	1
04W2-00005-00	975954	Stop-Wellenmutter 25x1,5	Stop-Shaft nut	ECROU 25X1,5	DADO ALBERO DZ/FZ	1
04X1-00004-00	972165	Sicherungsblech MB4	Safety sheet metal	RONDELLE DE SECURITE MB4	LAMIERA DI SICUREZZA DZ	1
04Z3-03210-00	969595	Schräg-Kugellag. 3210-2RS	ang. ball-bear. 3210-2RS	Roul. oscillant 3210-2RS	CUSCINETTO 3210-2RS	1
05C1-16171-14	972186	Kupferdichtung G 1/4	copper seal G 1/4	JOINT CUIVRE G 1/4	RONDELLA TENUTA RAME 1/4"	1
05M1-00210-06	972203	MEGU-RING 7,3/10,2x1,00	MEG-U-Ring 7,3/10,2/1	U-Ring 7,3/10,2/1,00	GUARNIZ. MEG-U DZ/FZ	1
05M1-00211-08	972204	MEGU-Ring 8,5/13,4x1,00	MEG-U-Ring 8,5/13,4x1	MEG-U-Ring 8,5/13,4x1	RONDELLA	28
05O1-00050-25	972210	O-Ring 5x2,5 N 70	O-ring d.5x2,5 N 70	O-Ring 5x2,5 N 70	O-RING 5x2,5 N 70	1
05O1-00050-25	972210	O-Ring 5x2,5 N 70	O-ring d.5x2,5 N 70	O-Ring 5x2,5 N 70	O-RING 5x2,5 N 70	3
05O1-00290-25	964789	O-Ring Dm 290 x 2.5	O-Ring dia 290 x 2.5	O-Ring Dm 290 x 2.5	O-Ring Dm 290 x 2.5	1
05O1-00380-30	979547	O-Ring 38x3	O-Ring 38x3 (Cover 40)	O-Ring 38x3	O-Ring 38x3	1
05O1-00400-25	969599	O-Ring 40x2.5 N 70	O-Ring 40x2.5 N 70	O-Ring 40x2.5 N 70	O-Ring 40x2.5 N70	1
05O1-00540-40	979550	O-Ring 54x4 N 70	O-Ring 54x4 N 70	O-Ring 54x4 N 70	O-Ring 54x4 N 70	1
05O1-01050-25	972294	O-Ring 105x2,5 N 70	O-ring d.105x2,5 N 70	O-Ring 105x2,5 N70	O-RING 105x2,5 N 70 DZ	1
05O1-01100-25	969600	O-Ring 110x2.5 N 70	O-Ring 110x2.5 N 70	O-Ring 110x2.5 N 70	O-Ring 110x2.5 N70	2
05O1-01100-35	974850	O-Ring 110x3,5 N 70	O-Ring 110x3,5	O-Ring 110x3,5 N70	O-Ring 110x3,5 FZ	2
05S2-00250-70	972316	Simmerring A 25/35/7 NBR	Simmerring A 25/35/7 NBR	Simmerring A 25/35/7 NBR	Simmerring A 25/35/7 NBR	1
05S2-00380-50	979580	Sim.ring A 38/54/5 NBR Rf	Retaining ring 38/54/5	Joint à lèvres A 38/54/5	ANELLO TENUTA 38x54x5 NBR	1
05S2-00450-50	963545	Sim. ring A 45/62/5	Shaft seal A 45/62/5	Sim. ring A 45/62/5	Sim. ring A 45/62/5	1
05S2-00650-80	984901	Sim.Ring A 65/80/8 NBR-RF	Sim.Ring A 65/80/8 NBR-RF	Sim.Ring A 65/80/8 NBR-RF	Sim.Ring A 65/80/8 NBR-RF	1
05S2-01210-95	972342	Sim.ring A121/140/9,5 RF	Seal A 121/140/9.5 RF	Joint lèvres A121/140/9.5	ANELLO TENUTA 121x140x9.5	1
07S2-07013-14	972789	Stecknippel 1/4" A1-WR013	Plug-in nipple1/4A1-WR013	Coupleur 1/4 A 1-WR013	RACC.ACQUA MASCH.1/4" MA	1
13G4-11626-06	973616	Bügelgriff GN-565.1	Shackle crank	POIGNEE HCCB-4/DZ/FZ	IMPUGNATURA A MANIGLIA	2
13V1-14501-00	973638	Verschl.Schr.m.Magnet 3/8	drain plug with magn. 3/8	BOUCH VIDANG MAGNETIQUE 3	TAPPO SERBATOIO OLIO CENT	1
XXKL-00000-41	976120	Polycarbon. Schild HS B4	Polycarbn. plate HS B4	Polycarbon. Schild HS B4	SCRITTA PLASTICA HYD. HCC	1

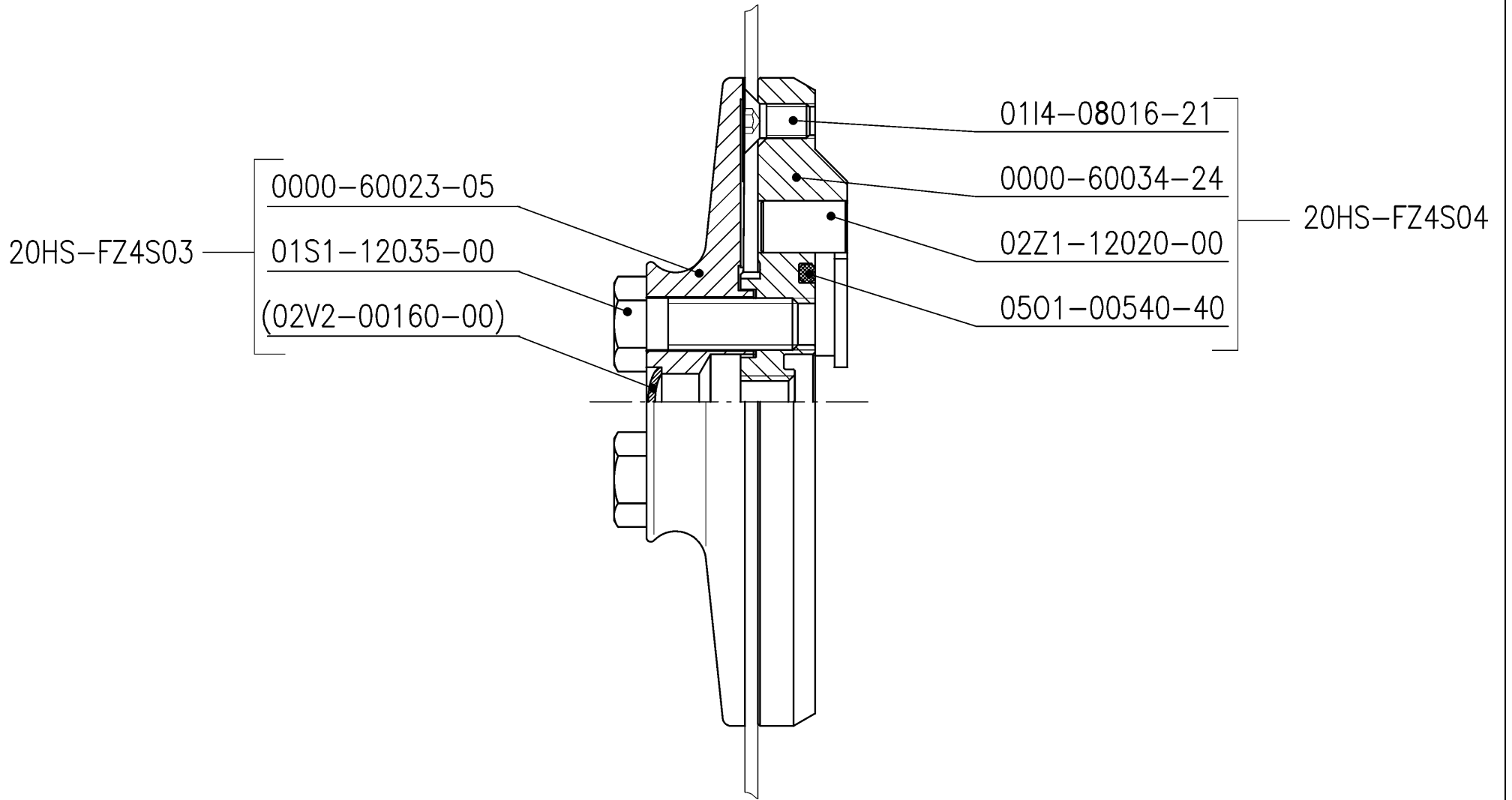

99MS-60020-4510977882		Schnelltrennflansch				pcs.
20HS-FZ4S03	999756	Blattdeckel zu Schnelltrennflansch				1
0000-60023-05	984759	Blattdeckel	Blade cover	Blattdeckel	Flangia disco due dadi	1
01S1-12035-00	969911	6kt. Schraube M12x35	hex. screw M12x35	6kt. Schraube M12x35	Vite M12x35	2
20HS-FZ4S04	10977880	Blattflansch				1
0000-60034-24	10977478	Blattaufnahme	Blattaufnahme	Blattaufnahme	Blattaufnahme	1
02Z1-12020-00	984930	Zylinderstift Dm12x20	Zylinderstift Dm12x20	Zylinderstift Dm12x20	Zylinderstift Dm12x20	2
05O1-00540-40	979550	O-Ring 54x4 N 70	O-Ring 54x4 N 70	O-Ring 54x4 N 70	O-Ring 54x4 N 70	1
01I4-08016-21	971825	Senkkopfschraube M 8x 16	Countersunk screw M8x16	Senkkopfschraube M 8x 16	Vite t. svasata M8X16	6
BZDA-999146	10977081	Beipackzettel	Beipackzettel	Beipackzettel	Beipackzettel	1
7777-0ETUI-01	10977101	Transparent Etui A6	Transparent Etui A6	Transparent Etui A6	Transparent Etui A6	1

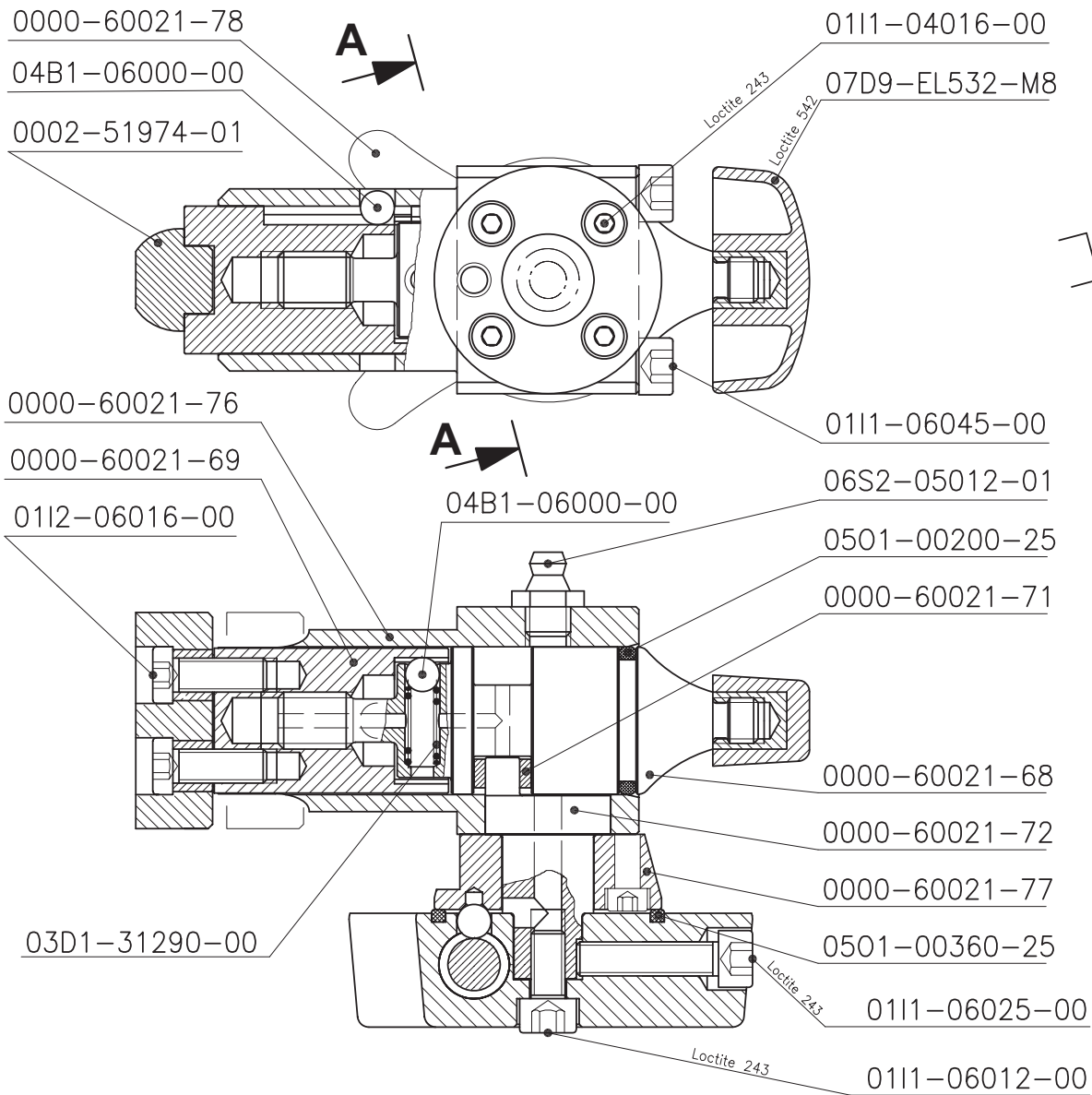

Schnitt A-A

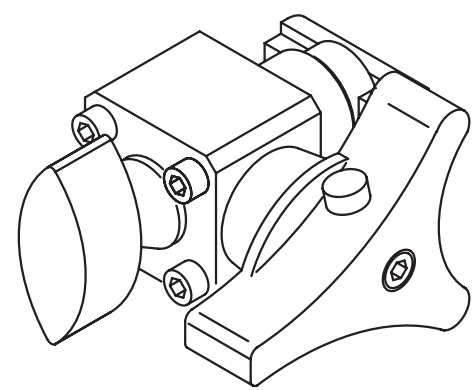
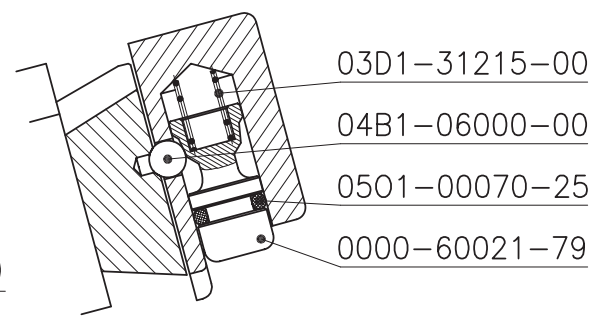

99MS-60021-93	963548	Y-Schlittenführung rechts	Glissière de char. Y droite	Y-Carriage guide right	Guida del carrello Y destra	pcs.
0000-60021-68	977717	Exzenterwelle (Raster)	ECentricshaft (Raster)	Arbre excentrique	ALBERO A TACCHE X GUIDA	1
0000-60021-69	977718	Prismenschieber (Raster)	Prism slide (grid)	Vanne prismatique	CURSORE A TACCHE GUIDA	1
0000-60021-71	977719	Druckplatte	pressure Plate	Cale de répart. de pressi	PIASTRA DI PRESS. PER GUI	1
0000-60021-72	977720	Exzenter	Excentre disc	Excentre disque	ECCENTRICO GUIDA	1
0000-60021-76	977724	Gehäuse	Housing	Carter	SCATOLA GUIDA	1
0000-60021-77	977725	Rasterplatte	Latch plate	Plaque moteur	PIASTRA A TACCHE	1
0000-60021-78	977726	Griff rechts	grip right	Poignée droite	MANIGLIA GUIDA DX	1
0000-60021-79	977727	Rastbolzen	Latchbolt	Axe d'arrêt	PULSANTINO GUIDA	1
0002-51974-01	971203	Prisma	Prisma	Prisma	Prisma	1
0111-04016-00	971680	Inbus-Schraube M 4x 16	Socket screw M 4x 16	Inbus-Schraube M 4x 16	VITE M 4x 16	4
0111-06012-00	971704	Inbus-Schraube M 6x 12	Allen screw	Vis CHC M6x12	VITE BRUGOLA M6X12 TENSIO	1
0111-06025-00	971711	Inbus-Schraube M 6x 25	Allen screw	Vis CHC M6x25	VITE BRUGOLA M6X25	1
0111-06045-00	971716	Inbus-Schraube M 6x 45	Socket screw M 6x 45	Vis CHC M6x45	VITE BRUGOLA M6X45	4
0112-06016-00	971809	Inb-Schr.nied.KopfM 6x 16	Allen screw M 6x 16	Vis HC tête basse M6x16	VITE BRUG. M6X16 PRISMA D	2
03D1-31215-00	968733	Druckfeder Dm 6.3x0.8x23	cp. spring dia6.3x0.8x23	Ressort diam. 6.3x0.8x23	MOLLA X GUIDA Dm6.3x0.8x23	1
03D1-31290-00	968671	Druckfeder Dm 5x1x17	comp. spring dia 5x1x17	Ressort diam. 5x1x17	MOLLA X GUIDA Dm 5x1x17	1
04B1-06000-00	979462	Kugel Dm 6	ball dia 6	Kugel Dm 6	SFERA DM 6 PER GUIDA	3
05O1-00070-25	972213	O-Ring 7x2,5 N 70	O-Ring 7x2,5 N 70	O-Ring 7x2,5 N 70	O-Ring 7x2,5 DZ-FZ	1
05O1-00200-25	972234	O-Ring 20x2,5 N 70	O-Ring 20x2,5 N 70	O-RING 20 X 2,5	O-Ring 20x2,5 DZ-FZ CR-3	1
05O1-00360-25	972256	O-Ring 36x2,5 N 70	O-Ring 36x2,5 N 70	O-Ring 36x2,5 N 70	O-Ring 36x2,5	1
06S2-05012-01	972464	Schmiernippel H1 NPT 1/8	Grease nipple H1 NPT 1/8	GRAISSEUR H1 NPT 1/8	VALVOLA INGRASSAGGIO AZ	1
07D9-EL532-M8	968679	Flügelmutter M8	Fly nut M8	Ecrou papillon M8	POMELLO GUIDA M8	1

0000-60021-86
04B1-06000-00
0002-51974-01

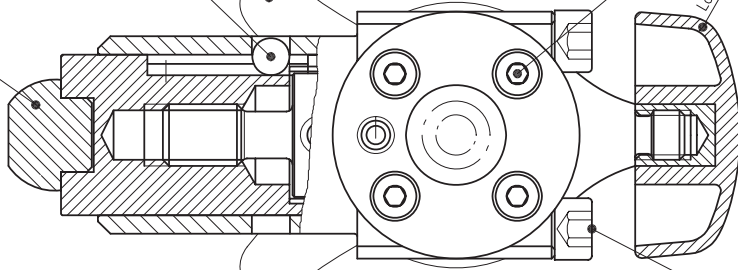

0111-04016-00
07D9-EL532-M8

Loctite 243
Loctite 542

Schnitt A-A

0000-60021-79
0501-00070-25
04B1-06000-00
03D1-31215-00

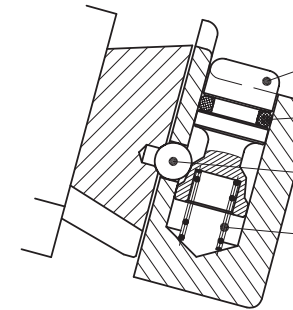

0000-60021-76
0000-60021-69
0112-06016-00

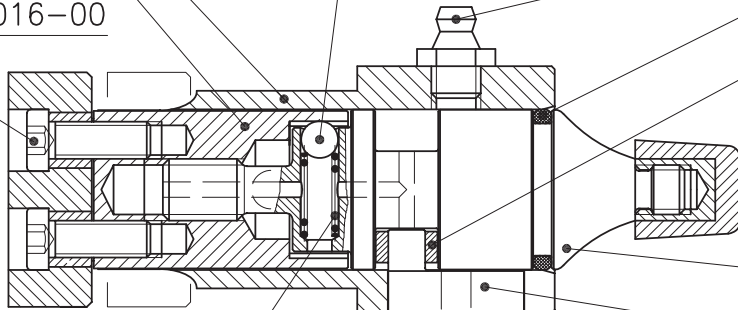

04B1-06000-00

0111-06045-00
06S2-05012-01
0501-00200-25
0000-60021-71

0000-60021-68
0000-60021-72
0000-60021-77
0501-00360-25

03D1-31290-00

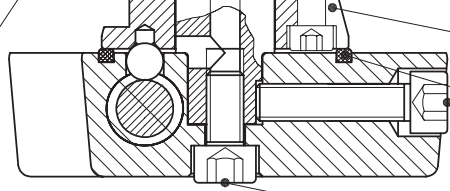

Loctite 243

0111-06025-00
0111-06012-00

Loctite 243

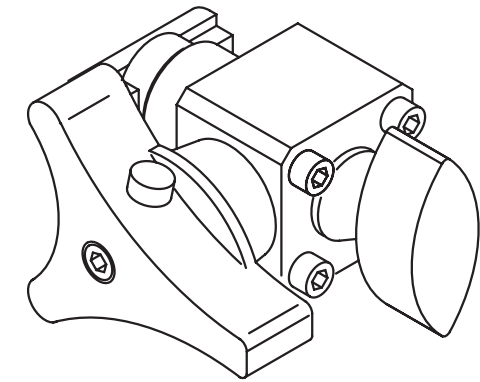

99MS-60021-94	963547	Y-Schlittenführung links	Gliss. de char. Y gauche	Y-Carriage guide left	Guida del carrello Y sinistra	pcs.
0000-60021-68	977717	Exzenterwelle (Raster)	ECentricshaft (Raster)	Arbre excentrique	ALBERO A TACCHE X GUIDA	1
0000-60021-69	977718	Prismenschieber (Raster)	Prism slide (grid)	Vanne prismatique	CURSORE A TACCHE GUIDA	1
0000-60021-71	977719	Druckplatte	pressure Plate	Cale de répart. de pressi	PIASTRA DI PRESS. PER GUI	1
0000-60021-72	977720	Exzenter	Excentre disc	Excentre disque	ECCENTRICO GUIDA	1
0000-60021-76	977724	Gehäuse	Housing	Carter	SCATOLA GUIDA	1
0000-60021-77	977725	Rasterplatte	Latch plate	Plaque moteur	PIASTRA A TACCHE	1
0000-60021-79	977727	Rastbolzen	Latchbolt	Axe d'arrêt	PULSANTINO GUIDA	1
0000-60021-86	977732	Griff links	grip left	Poignée gauche	MANIGLIA GUIDA SX	1
0002-51974-01	971203	Prisma	Prisma	Prisma	Prisma	1
0111-04016-00	971680	Inbus-Schraube M 4x 16	Socket screw M 4x 16	Inbus-Schraube M 4x 16	VITE M 4x 16	4
0111-06012-00	971704	Inbus-Schraube M 6x 12	Allen screw	Vis CHC M6x12	VITE BRUGOLA M6X12 TENSIO	1
0111-06025-00	971711	Inbus-Schraube M 6x 25	Allen screw	Vis CHC M6x25	VITE BRUGOLA M6X25	1
0111-06045-00	971716	Inbus-Schraube M 6x 45	Socket screw M 6x 45	Vis CHC M6x45	VITE BRUGOLA M6X45	4
0112-06016-00	971809	Inb-Schr.nied.KopfM 6x 16	Allen screw M 6x 16	Vis HC tête basse M6x16	VITE BRUG. M6X16 PRISMA D	2
03D1-31215-00	968733	Druckfeder Dm 6.3x0.8x23	cp. spring dia6.3x0.8x23	Ressort diam. 6.3x0.8x23	MOLLA X GUIDA Dm6.3x0.8x23	1
03D1-31290-00	968671	Druckfeder Dm 5x1x17	comp. spring dia 5x1x17	Ressort diam. 5x1x17	MOLLA X GUIDA Dm 5x1x17	1
04B1-06000-00	979462	Kugel Dm 6	ball dia 6	Kugel Dm 6	SFERA DM 6 PER GUIDA	3
05O1-00070-25	972213	O-Ring 7x2,5 N 70	O-Ring 7x2,5 N 70	O-Ring 7x2,5 N 70	O-Ring 7x2,5 DZ-FZ	1
05O1-00200-25	972234	O-Ring 20x2,5 N 70	O-Ring 20x2,5 N 70	O-RING 20 X 2,5	O-Ring 20x2,5 DZ-FZ CR-3	1
05O1-00360-25	972256	O-Ring 36x2,5 N 70	O-Ring 36x2,5 N 70	O-Ring 36x2,5 N 70	O-Ring 36x2,5	1
06S2-05012-01	972464	Schmiernippel H1 NPT 1/8	Grease nipple H1 NPT 1/8	GRAISSEUR H1 NPT 1/8	VALVOLA INGRASSAGGIO AZ	1
07D9-EL532-M8	968679	Flügelmutter M8	Fly nut M8	Ecrou papillon M8	POMELLO GUIDA M8	1

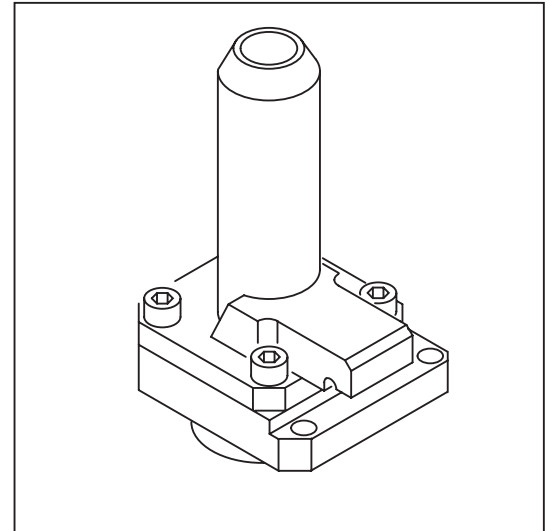
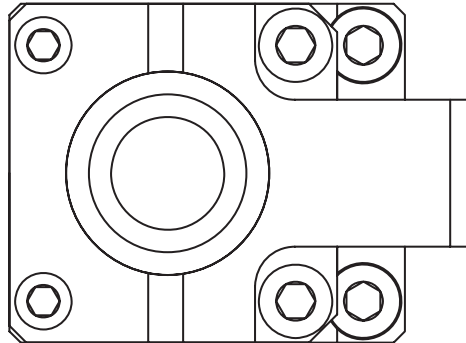
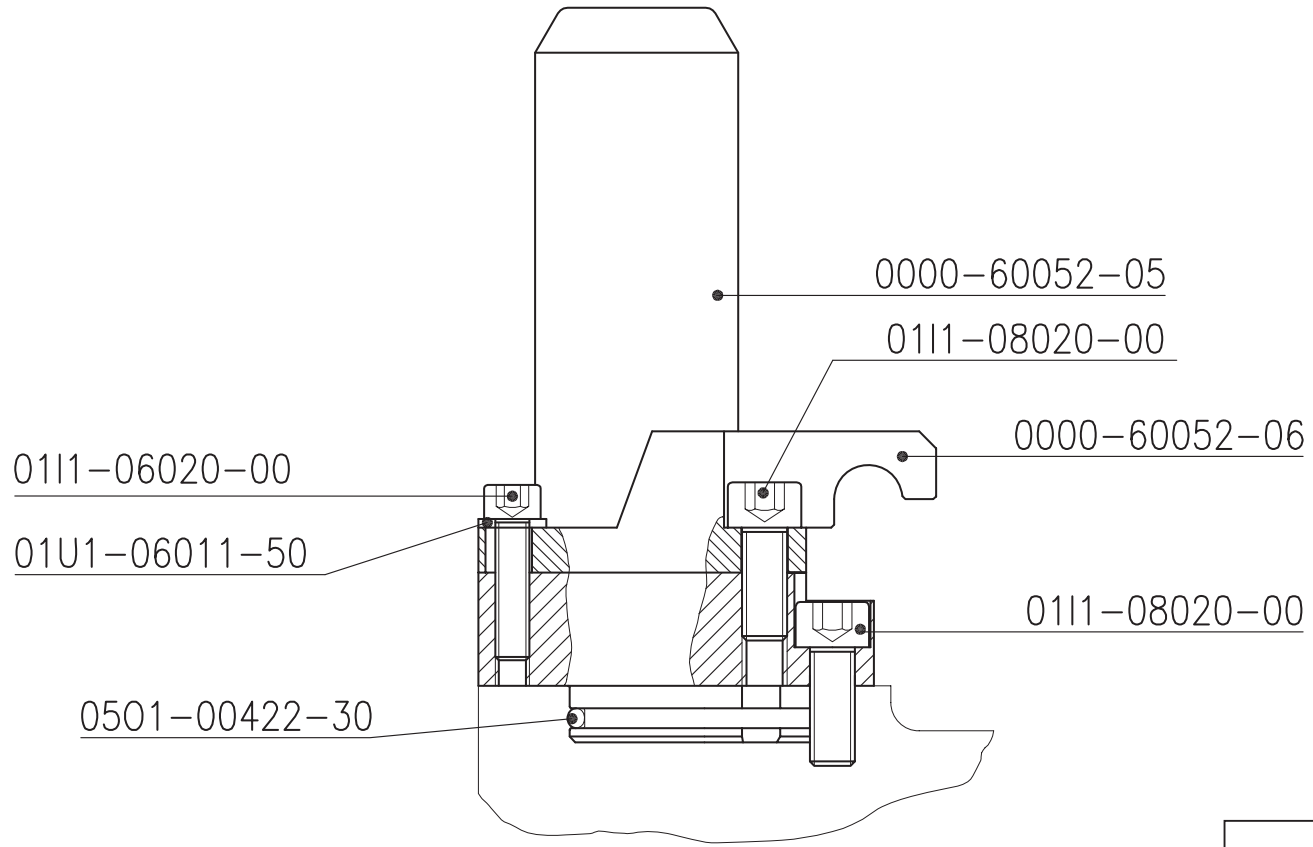

99MS-60052-10	968764	Blattschutzaufnahme	Blattschutzaufnahme	Blattschutzaufnahme	Blattschutzaufnahme	pcs.
0000-60052-05	977948	Zentrierbolzen	centering bolt US	Zentrierbolzen US	Zentrierbolzen US	1
0000-60052-06	977949	Zentrierplatte	centering plate US	Zentrierplatte US	Zentrierplatte US	1
0111-06020-00	971709	Inbus-Schraube	Socket screw M 6x 20	Vis CHC M6x20	VITE BRUGOLA M6X20	2
0111-08020-00	979283	Inbus-Schraube	Allen screw M8 x 20	Vis CHC M 8 x 20	VITE M 8 x 20	6
0501-00422-30	979549	O-RING 42 x 3	O-Ring 42 x 3 N70	O-Ring 42 x 3 N70	O-Ring 42 x 3 N70	1
01U1-06011-50	971955	U-Scheibe M6	Washer	U-Scheibe M6	RONDELLA M6	2

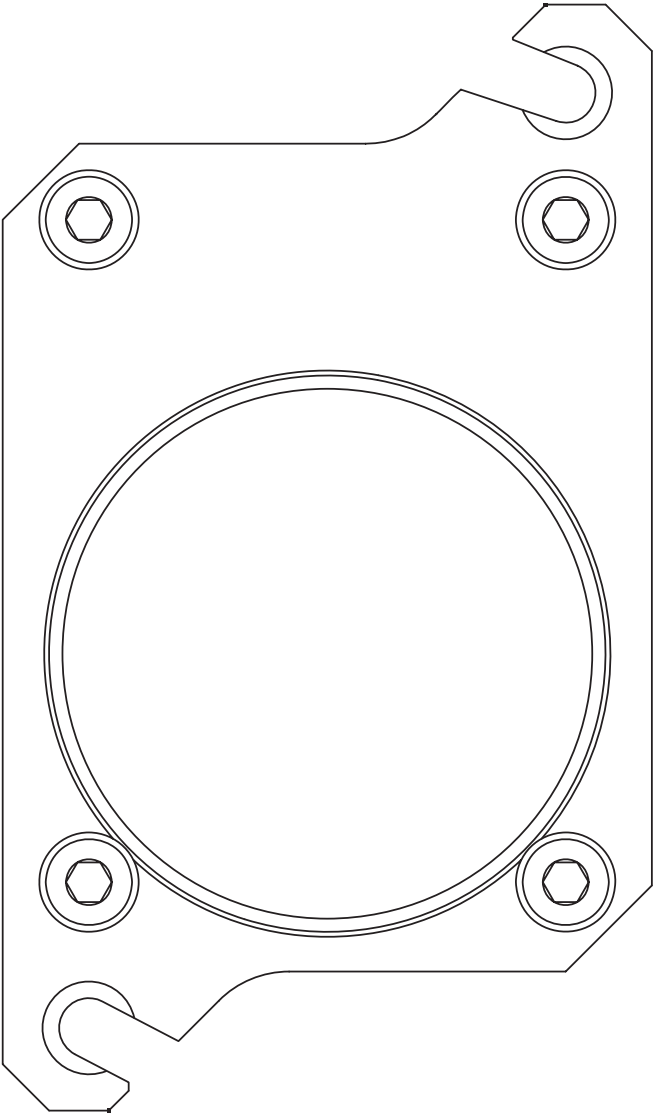

01M3-08000-60

01I6-08030-23

01U1-08015-50

0001-53391-01

0001-53391-03

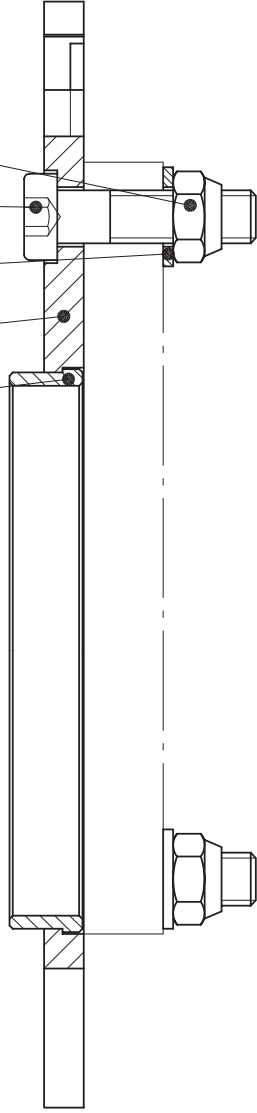

20HS-AZ006	973892	Gr.2 Schnellwechselsatz	Raccord rapide du moteur	Quick change set	Set per cambiamento rapido	pcs.
0001-53391-01	970942	Motorplatte AZ-S Schnellw	MotorPlate AZ-S rapid chg	Motorplatte AZ-S Schnellw	Motorplatte AZ-S Schnellw	1
0001-53391-03	970944	Zentrierring AZ-S Schnellw	centering ring AZ-S	CENTERING RING	Zentrierring AZ-S Schnellw	1
01I6-08030-23	971835	Inb-Schr.extr.n.KopfM8x30	all.screwextr.flhd M8x30	Vis HC Tête plate M8x30	VITE BRUGOLA M8X30 BASSA	4
01M3-08000-60	971861	Stop-Mutter M8 nied.Form	stop-nut M8 thin head	Ecrou Nylstop M8	DADO	4
01U1-08015-50	979353	U-Scheibe M8	washer M8	Rondelle M8	RONDELLA M8	4

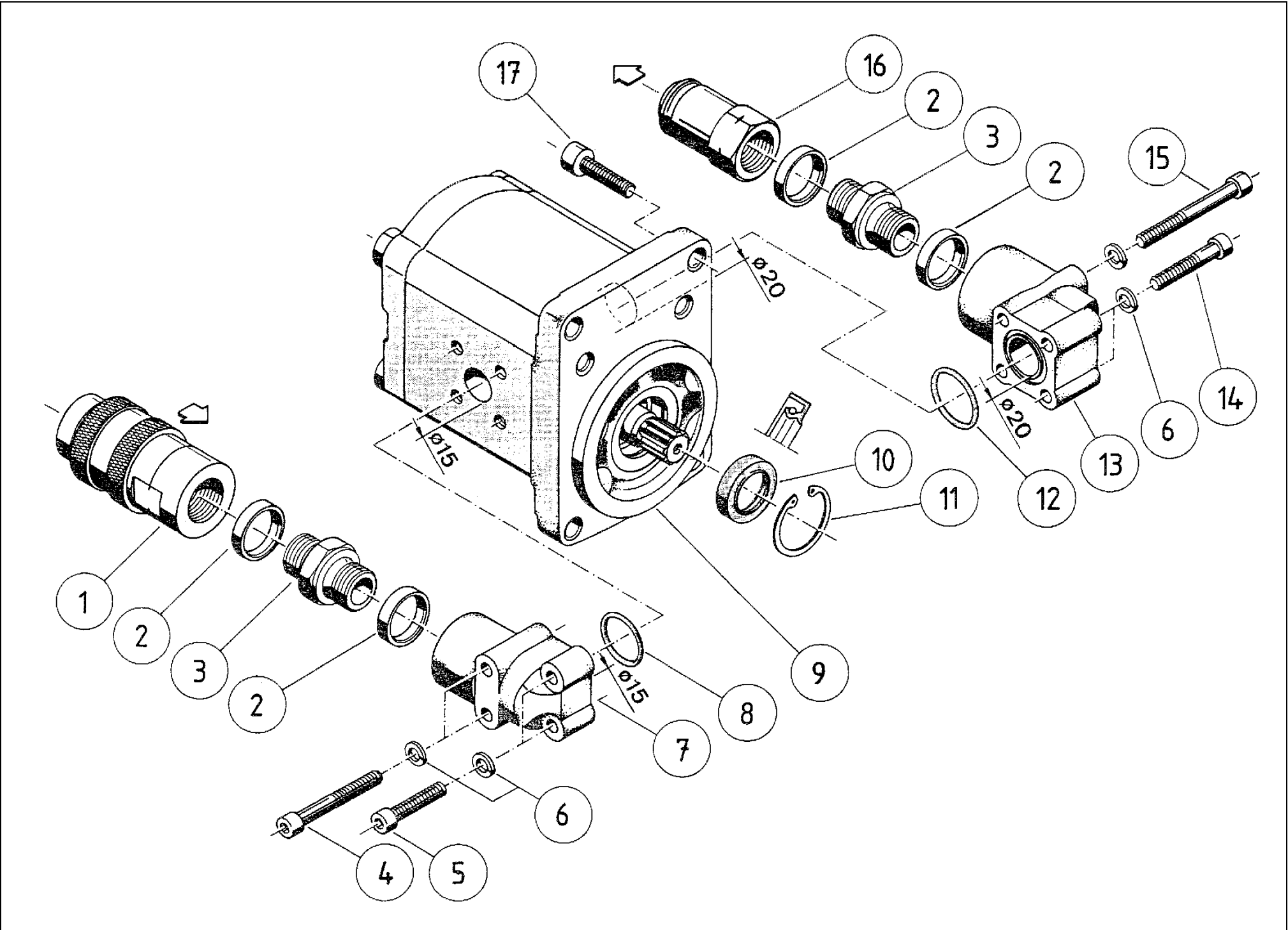

pos.	99MM-32005-__	Sägemotor Gr. 2	Saw motor Gr. 2	Moteur de sciage Gr. 2	Motore della sega	pcs.
1	07S1-00501-12	Kupplung	Coupling	Raccord femelle	Giunto	1
1A	07S1-00801-12	Kupplung FD Mut 1/2"	Coupling	Raccord femelle	Giunto	1
2	08D1-80341-12	Dichtring G 1/2"	Sealing ring	Anneau d'étanchéité	Anello di guarnizione	4
3	14D4-90201-12	Einschraubstutzen G1/2"-G1/2"	Screw-type connection piece	Manchon vissé	Gomito ad avvitamento	2
4	01I1-06045-00	Inbusschraube M6x45	Allen head screw	Vis à six pans creux	Vite ad esagono cavo	2
5	01I1-06030-00	Inbusschraube M6x30	Allen head screw	Vis à six pans creux	Vite ad esagono cavo	2
6	01F1-06000-50	Federring M6 DIN 127A	Spring washer	Rondelle élastique bombée	Rosetta elastica	8
7	07FI-61210-12	Motorflansch 2BK 1/2"-35	Motor flange	Bride de moteur	Flangia motore	1
8	05O1-00190-25	O-Ring 19x2,5	O-Ring	O-ring	Guarnizione OR	1
9	07M2-32205-__	Motor Bosch Gr 2	Motor	Moteur	Motore	1
10	05S1-00180-78B	Simmering	Shaft seal	Bague à lèvres avec ressort	Guarnizione anello albero	1
11	02S2-03015-50	Seegerring	Seeger circlip ring	Anneau de retenue type Seeger	Anello tipo Seeger	1
12	05O1-00220-25	O-Ring 22x2,5 N70	O-ring	O-ring	Guarnizione OR	1
13	07F1-61203-12	Motorflansch 2BK 1/2"-40	Motor flange	Bride de moteur	Flangia motore	1
14	01I1-06035-00	Inbusschraube M6x35	Allen head screw	Vis à six pans creux	Vite ad esagono cavo	2
15	01I1-06055-00	Inbusschraube M6x55	Allen head screw	Vis à six pans creux	Vite ad esagono cavo	2
16	07S1-00502-12	Nippel NS 502-BSP-F	Nipple	Raccord mâle	Raccordo	1
16A	07S1-00802-12	Nippel FD Vat.1/2"	Nipple	Raccord mâle	Raccordo	1
17	20D1-BOSOF-00	Dichtsatz Gr. F	Sealing kit	Jeu de garnitures	Set di guarnizione	1

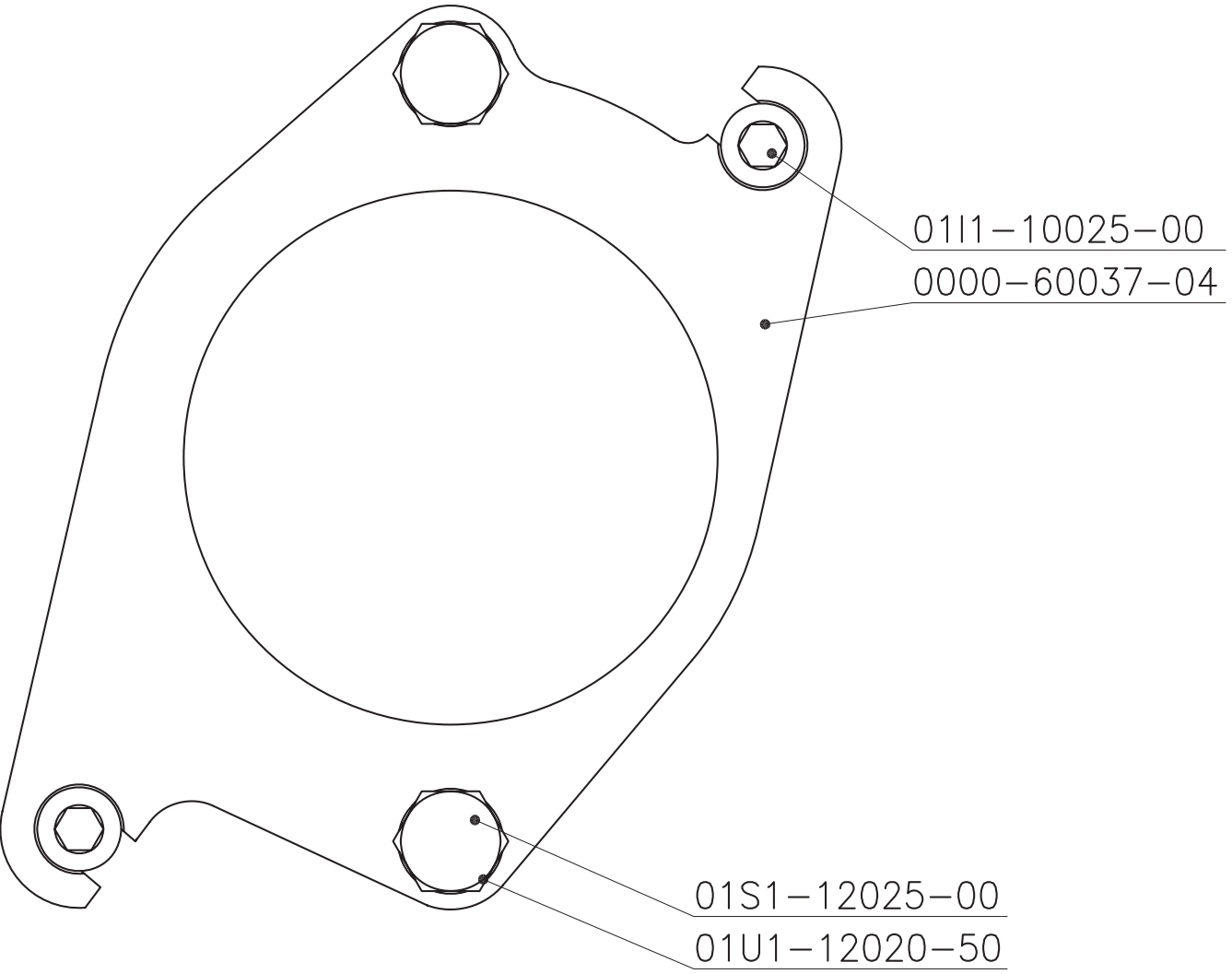

20HS-FZ001	976133	Gr.3 Schnellwechselsatz	Raccord rapide du moteur	Quick change set	Set per cambiamento rapido	pcs.
0000-60037-04	977850	Motorplatte Gr.3	MotorPlate Gr.3	Plaque moteur Gr.3	Motorplatte Gr.3	1
01S1-12025-00	971915	6kt-Schraube M12x25	hex.-screw M12x25	Vis 6 pans M12x25	VITE M12x25	2
01I1-10025-00	971764	Inbus-Schraube M10x 25	Socket screw M10x 25	Vis CHC M10x25	VITE M10x 25	2
01U1-12020-50	979354	U-Scheibe M12	Washer M12	Rondelle M12	RONDELLA M12	2

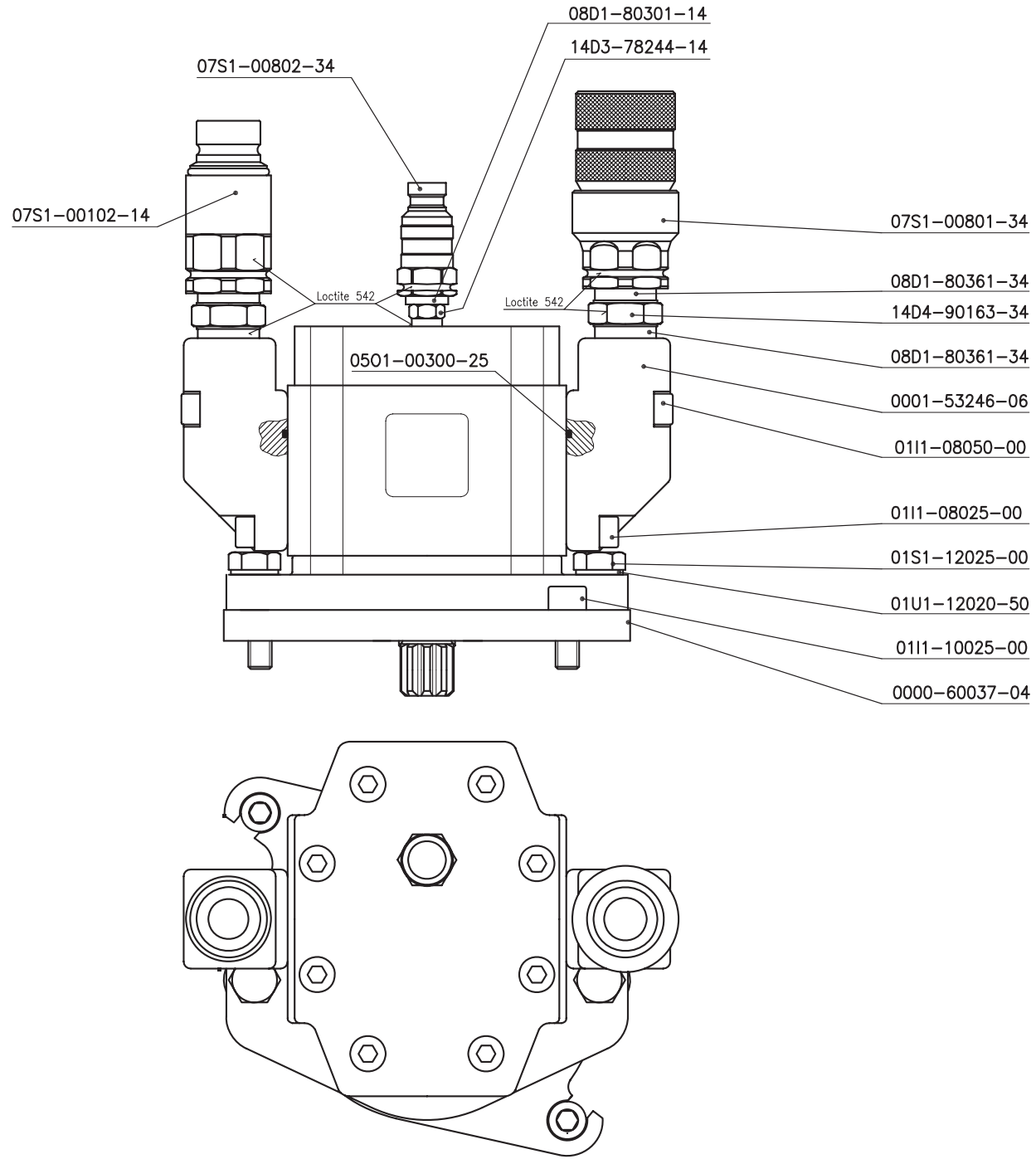

99MM-34008-020	976164	Motor kpl. 20ccm/FD	Saw motor 20ccm/FD	Moteur de sciage 20ccm/FD	Motor della sega 20ccm/FD
99MM-34008-025	976165	Motor kpl. 25ccm/FD	Saw motor 25ccm/FD	Moteur de sciage 25ccm/FD	Motor della sega 25ccm/FD
99MM-34008-031	976166	Motor kpl. 31ccm/FD	Saw motor 31ccm/FD	Moteur de sciage 31ccm/FD	Motor della sega 31ccm/FD
99MM-34008-040	976167	Motor kpl. 40ccm/FD	Saw motor 40ccm/FD	Moteur de sciage 40ccm/FD	Motor della sega 40ccm/FD
99MM-34008-050	976168	Motor kpl. 50ccm/FD	Saw motor 50ccm/FD	Moteur de sciage 50ccm/FD	Motor della sega 50ccm/FD

0000-60037-04	977850	Motorplatte Gr.3	MotorPlate Gr.3	Plaque moteur Gr.3	Motorplatte Gr.3	1
0001-53246-06	970883	Motorwinkel RZ	Motor bracket RZ	COUDE MOTEUR H.P.I.	FLANGIA RACC. MOTORE GR.3	2
0111-08025-00	979284	Inbus-Schraube M8 x 25	Socket screw M 8x 25	Vis CHC M8x25	VITE M 8x 25	4
0111-08050-00	971745	Inbus-Schraube M 8 x 50	Socket screw M 8x 50	Vis CHC M8x50	VITE BRUGOLA M8X50	4
0111-10025-00	971764	Inbus-Schraube M10x 25	Socket screw M10x 25	Vis CHC M10x25	VITE M10x 25	2
01S1-12025-00	971915	6kt-Schraube M12x25	hex.-screw M12x25	Vis 6 pans M12x25	VITE M12x25	2
01U1-12020-50	979354	U-Scheibe M12	Washer M12	Rondelle M12	RONDELLA M12	2
05O1-00300-25	972248	O-Ring 30x2,5 N 70	O-ring d.30x2,5 N 70	O-Ring 30x2,5 N 70	O-RING 30x2,5 N 70	2
07S1-00102-14	972775	Leckoelanschluss 1/4 Zoll	Nipple	COUPLEUR 1/4 MALE N° 102	RACC.IDR.MA X RIFLUSSO CE	1
07S1-00801-34	975969	Kupplung FD Mut. 3/4 Zoll	Coupling 3/4" FD	Kupplung FD Mut. 3/4 Zoll	Kupplung FD Mut. 3/4 Zoll	1
07S1-00802-34	975971	Nippel FD VAT. 3/4 Zoll	Nipple 3/4" FD	Coupleur 3/4" FD mâle	Nippel FD Vat. 3/4 Zoll	1
08D1-80301-14	972860	Dichtkantenring G 1/4	Seal Edge ring G 1/4	Joint prismatique G 1/4	ANELLO TENUTA METAL.1/4	"1
08D1-80361-34	972863	Dichtkantenring G 3/4	Seal Edge ring G 3/4	Dichtkantenring G 3/4	DISTANZIALE 3/4	4
14D3-78244-14	980278	Festanschl. G1/4 -3/8 NPT	fix. conn. G1/4 -3/8 NPT	Raccord. G1/4 -3/8 NPT	Festanschl. G1/4 -3/8 NPT	1
14D4-90163-34	977526	Doppelstutzen G3/4-G3/4	dual connector G3/4-G3/4	Doppelstutzen G3/4-G3/4	NIPPLES MASCHIO 3/4"-3/4	"2

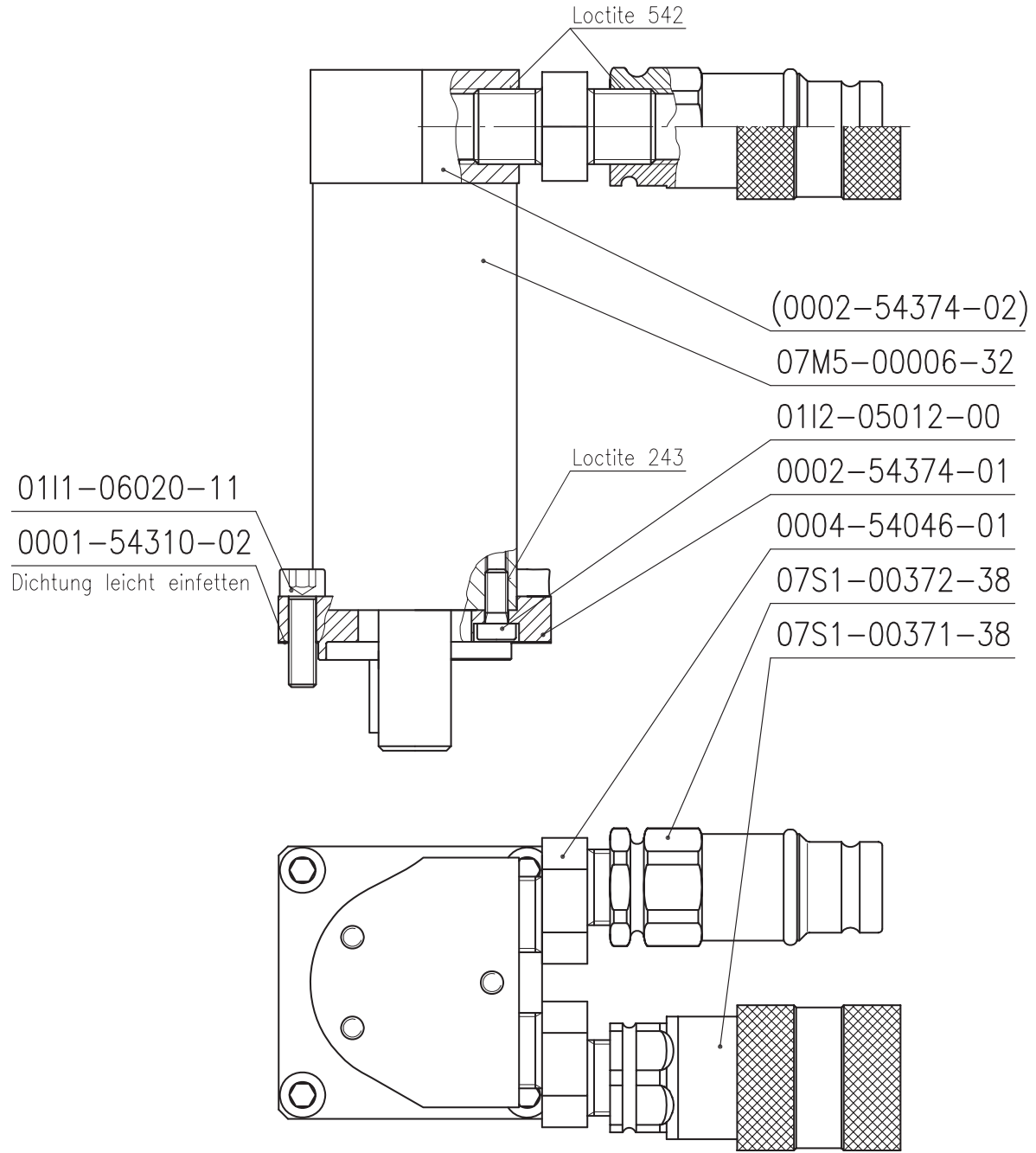

99MS-54565-01	976554	Vorschubmotor	Moteur d'avance	Feed advance motor	Motor d'avanzamento	pcs.
0001-54310-02	971180	Dichtung Vorschubmotor	Gasket, intake, engine	JOINT PAPIER MOTEUR AVANC	GUARNIZ.MOT.AVANZ.PENETRA	1
0002-54374-01	976402	Motorplatte OML Anbau	MotorPlate OML atthcmt	Plaque moteur OML	FLANGIA	1
0004-54046-01	971616	E-Nippel 3/8" NPT	E-nipple 3/8 NPT	MAMELON 3/8" DEPORTE	RACCORDO-E 3/8" DZ	2
0111-06020-11	971710	Inbus-Schraube M6x20 12.9	Al. head screw M6x20 12.9	Vis CHC M6x20 12.9	VITE BRUGOLA M6X20 12,9	4
0112-05012-00	971804	Inb-Schr.nied.KopfM 5x 12	allen screw flhd M 5x 12	Inb-Schr.nied.KopfM 5x 12	VITE M 5x 12	4
07M5-00006-32	976442	Hydraulikmotor OML 32	Hydraulic motor OML 32	Moteur hydraulique OML 32	MOTORE 32 OML	1
07S1-00371-38	979703	FF Kupplung 3/8 Zoll	Coupling 3/8	FF COUPLEUR 3/8	"RACCORDO BRUNING FEMM. 3/8	1
07S1-00372-38	979707	Nippel 3/8 Zoll	Nipple 3/9	Coupleur 3/8"	RACCORDO BRUNING MASCH.3/8	1

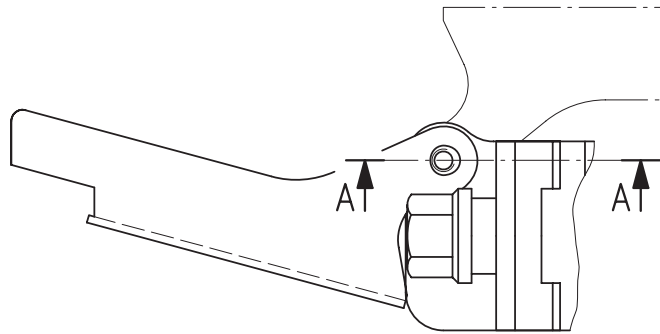
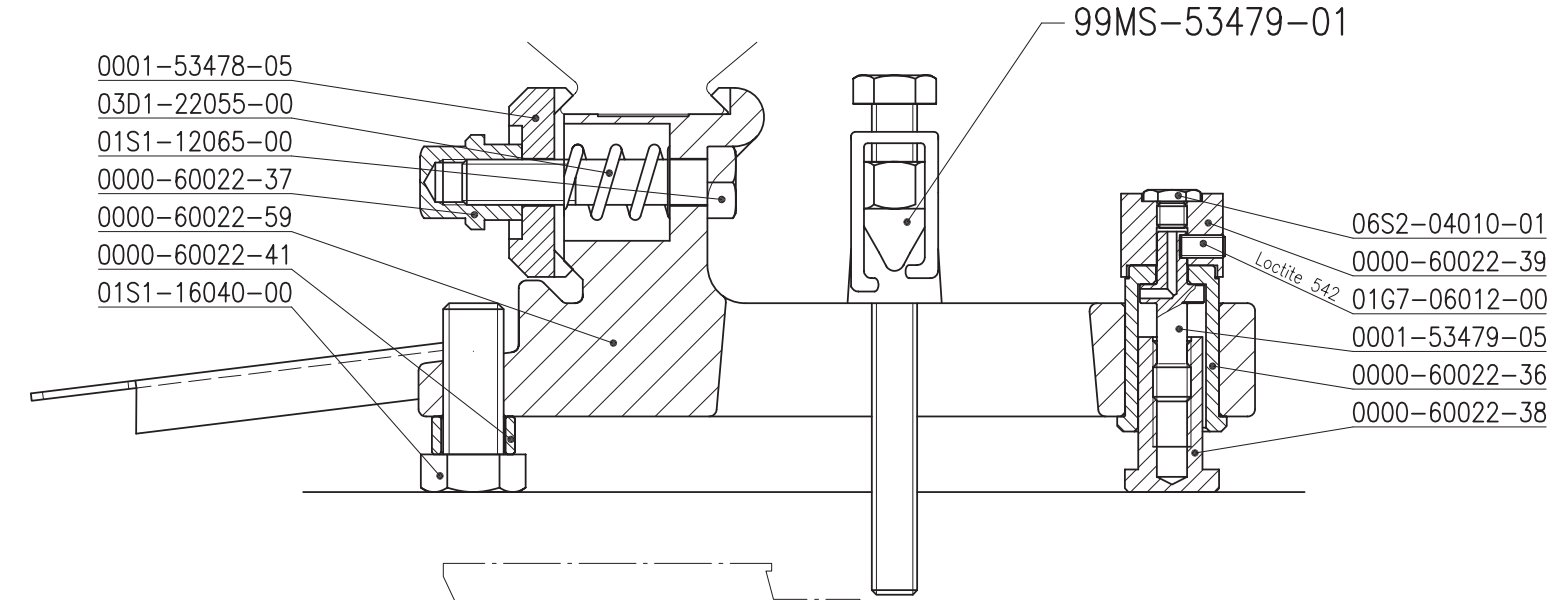

Schnitt A-A

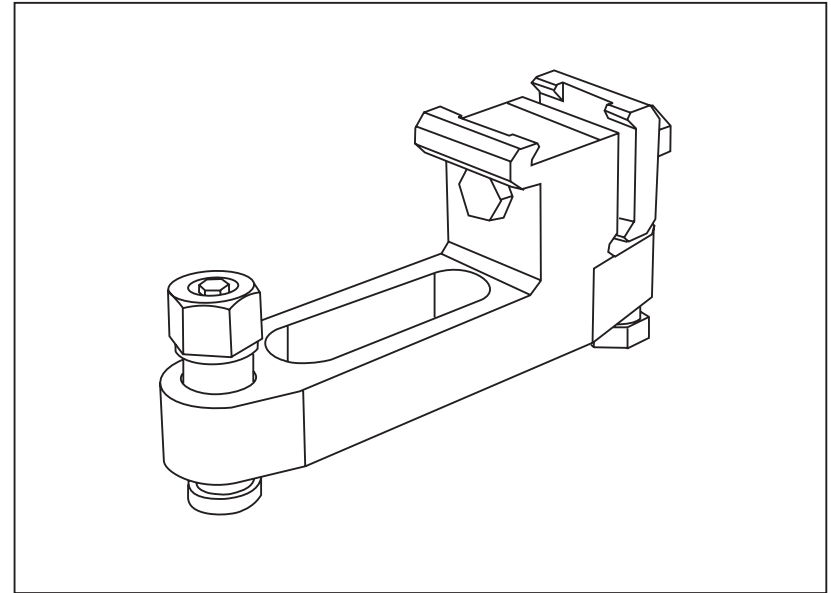
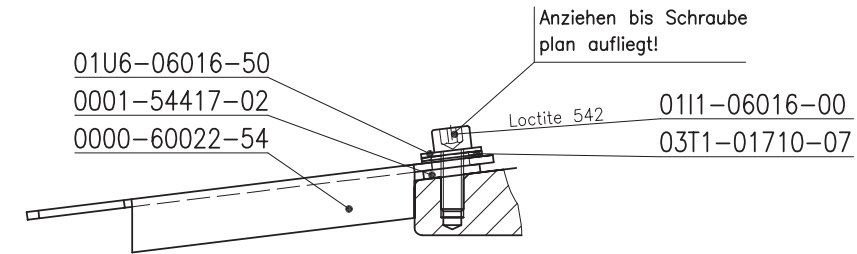

99MS-53675-01	974478	V-Schienenbock	V-track base	Sabot de fixation pour rail an V	Supporto die binari V	pcs.
99MS-53479-01	974476	Befestigungsklotz kpl.	Fixing block,cpl.	ENSEMBLE DE SERRAGE SABOT	VITE E FARFALLA COMPL N.S	1
0000-60022-36	961749	Führungsbüchse rostf.	Guide bushing staninless	Führungsbüchse rostf.	Führungsbüchse rostf.	1
0000-60022-37	961750	Hutmutter rostf.	Hutmutter rostf.	Ecrou borgne inox	DADO A CAPPELLO PIED. BIN	1
0000-60022-38	961751	Fuss rostf.	Fuss rostf.	Fuss rostf.	SUPPORTO PERNO PIED. AZ/S	1
0000-60022-39	961752	Spindelmutter rostf.	Spindelmutter rostf.	Spindelmutter rostf.	DADO DEL PERNO PIEDINO AZ	1
0000-60022-41	961753	Distanzring rostf.	Distanzring rostf.	Distanzring rostf.	Distanzring rostf.	1
0000-60022-54	968691	Zeiger Schienenbock	pointer for track foot	Aiguille sabot	ASTA CENTR.PIED.BIN.ALU	1
0000-60022-59	965449	Schienenbock (Stahlguss)	Schienenbock (Stahlguss)	Schienenbock (Stahlguss)	Schienenbock (Stahlguss)	1
0000-60060-50	978114	Mutter	nut M12 with seeger ring	Mutter	DADO FARFALLA SUPP.BIN.N.	1
0001-53478-05	974729	Klemmbride	Clamping strap	BRIDE DE SERRAGE SABOTS E	GANASCIA FISS. BIN. PIEDI	1
0001-53479-01	970969	Spannklotz	Tensioning block	BLOC TENDEUR SABOT " V	"FARFALLA VITE PIED. BINAR	1
0001-53479-05	970974	Spindel	Shaft	AXE DE REGLAGE DE SABOTS	PERNO FILET. REG. PIEDINO	1
0001-54417-02	975897	Zeigerbüchse	pointer bush	Zeigerbüchse	Zeigerbüchse	1
0003-54404-01	975931	Schnappfeder Befestigung	Catchspring fastening	Schnappfeder Befestigung	MOLLA BLOCCO FARF.SUPPORT	1
01G7-06012-00	971660	Gewindestift M 6x12	Set screw M 6 x 12	Clavette M6x12	GRANO M 6x12	1
01I1-06016-00	971705	Inbus-Schraube M 6x 16	Socket screw M 6x 16	Vis CHC M6x16	VITE BRUGOLA M6X16	1
01S1-12065-00	971921	6kt-Schraube M12x65	Hexagonal screw M12x65	Vis 6 pans M12x65	VITE M12x65 PIEDINO B4-B6	1
01S1-12130-00	971931	6kt-Schraube M12x130mm	hex.-screw M12x130mm	VIS H M12x130	VITE M 12 X 130 T.E.	1
01S1-16040-00	971938	6kt-Schraube M16x40	hex.-screw M16x40	6kt-Schraube M16x40	VITE M16 X 40 PIEDINO BIN	1
01U6-06016-50	975949	U-Scheibe Dm 6.4/16x0.8	washer dia 6.4/16x0.8	U-Scheibe Dm 6.4/16x0.8	RONDELLA Dm 6.4/16x0.8	1
02S6-01511-50	979387	Seegerring 15V-Welle	seeger ring 15V-shaft	Seegerring 15V-Welle	SEEGER DADO FARFALLA SUPP	1
03D1-22055-00	979424	Druckfeder Dm 29.0x4.0	comp. spring dia 29.0x4.0	RESSORT 29.0x4.0	MOLLA NUOVO SUPPORTO	1
03T1-01710-07	969364	Tellerfeder Dm17/10/0.7	disk spring dia17/10/0.7	Tellerfeder Dm17/10/0.7	Tellerfeder Dm17/10/0.7	2
06S2-04010-01	972462	Schmiernippel D1 M8	Lubricating nipple	GRAISSEUR D1 M8	VALVOLA INGR. PIED. HCCB	1
7777-VERPA-11	980467	Verpackung V-Schienenbock	packaging V-track-foot	Verpackung V-Schienenbock	VERPACKUNG V-Schienenbock	1

- V-Schiene 700 kompl. 99MS-00700-11
- V-Schiene 1100 kompl. 99MS-01100-11
- V-Schiene 1400 kompl. 99MS-01400-11
- V-Schiene 1800 kompl. 99MS-01800-11
- V-Schiene 2200 kompl. 99MS-02200-11

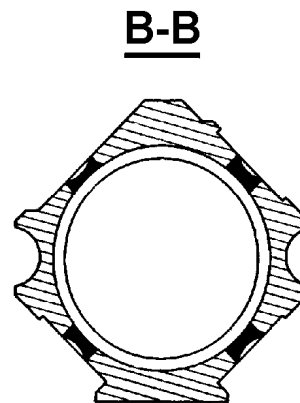
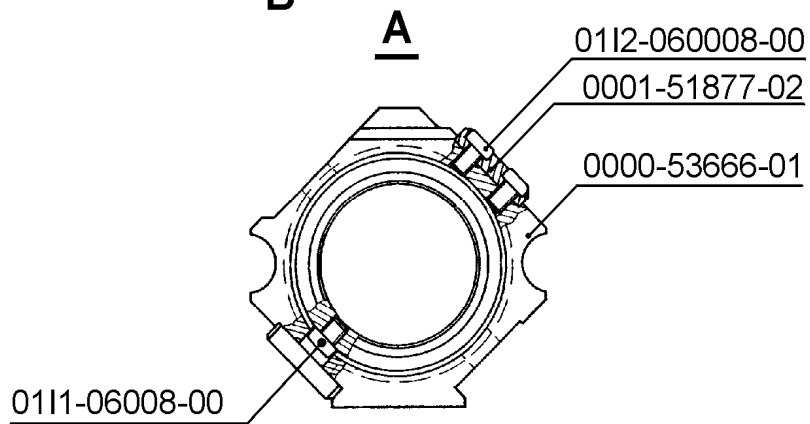
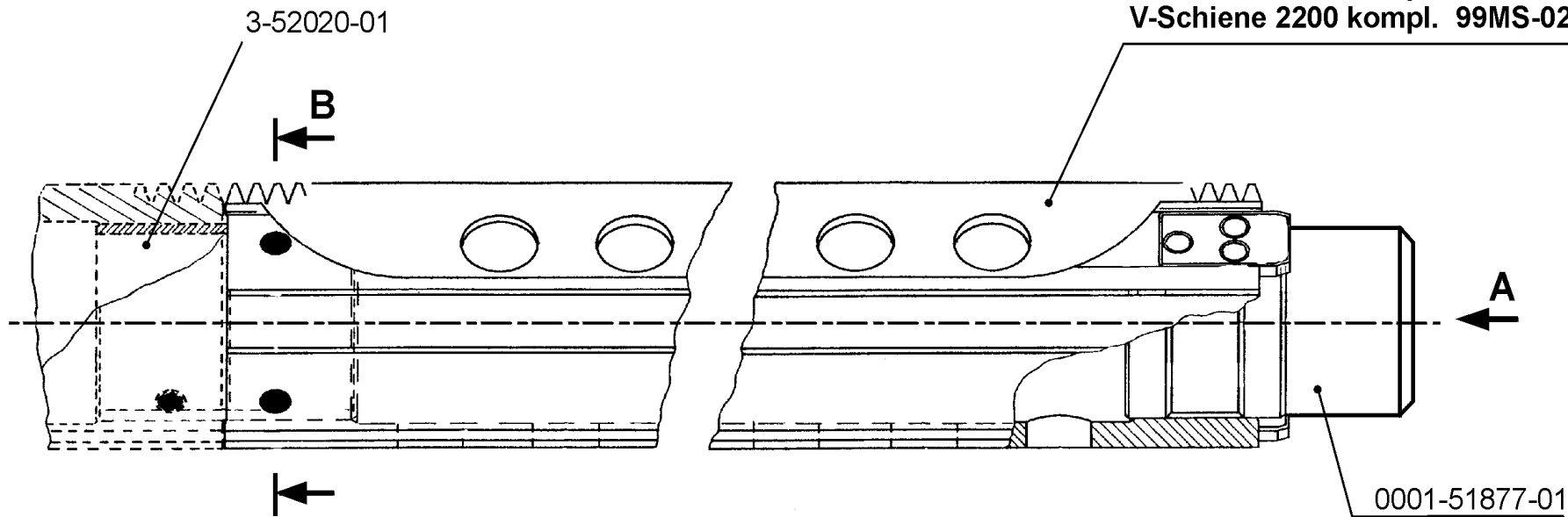

		VS-Schiene kpl.	VS-track compl.	Rail en VS complet	Binario VS compl.
99MS-00700-11	974398	V-Schiene VS kpl. 700	V-track VS compl. 700	Rail en VS complet 700	Binario VS compl. 700
99MS-01100-11	974400	V-Schiene VS kpl. 1100	V-track VS compl. 1100	Rail en VS complet 1100	Binario VS compl. 1100
99MS-01400-11	974402	V-Schiene VS kpl. 1400	V-track VS compl. 1400	Rail en VS complet 1400	Binario VS compl. 1400
99MS-01800-11	974404	V-Schiene VS kpl. 1800	V-track VS compl. 1800	Rail en VS complet 1800	Binario VS compl. 1800
99MS-02200-11	974406	V-Schiene VS kpl. 2200	V-track VS compl. 2200	Rail en VS complet 2200	Binario VS compl. 2200

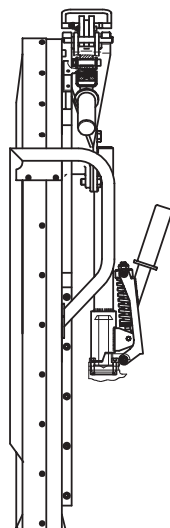
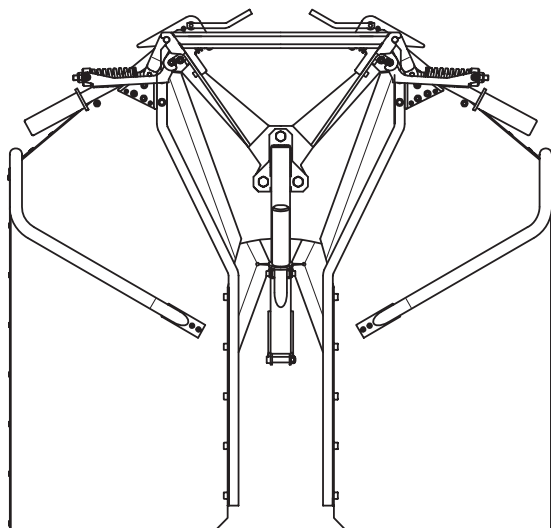

Ø 800 99MS-60111-10 / 999180
Ø 1000 99MS-60108-10 / 984240
Ø 1200 99MS-60105-10 / 962755

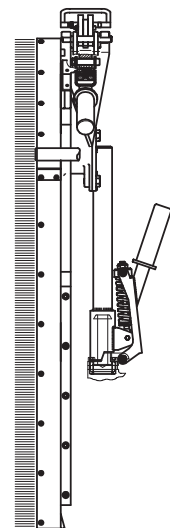
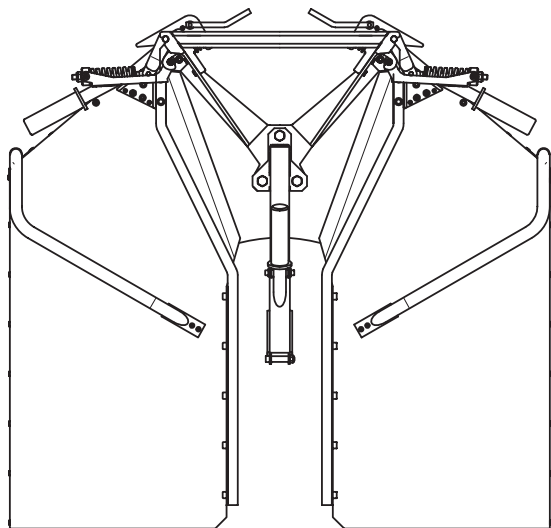

Ø 800 99MS-60111-80 / 999212
Ø 1000 99MS-60108-80 / 999160
Ø 1200 99MS-60105-85 / 999156

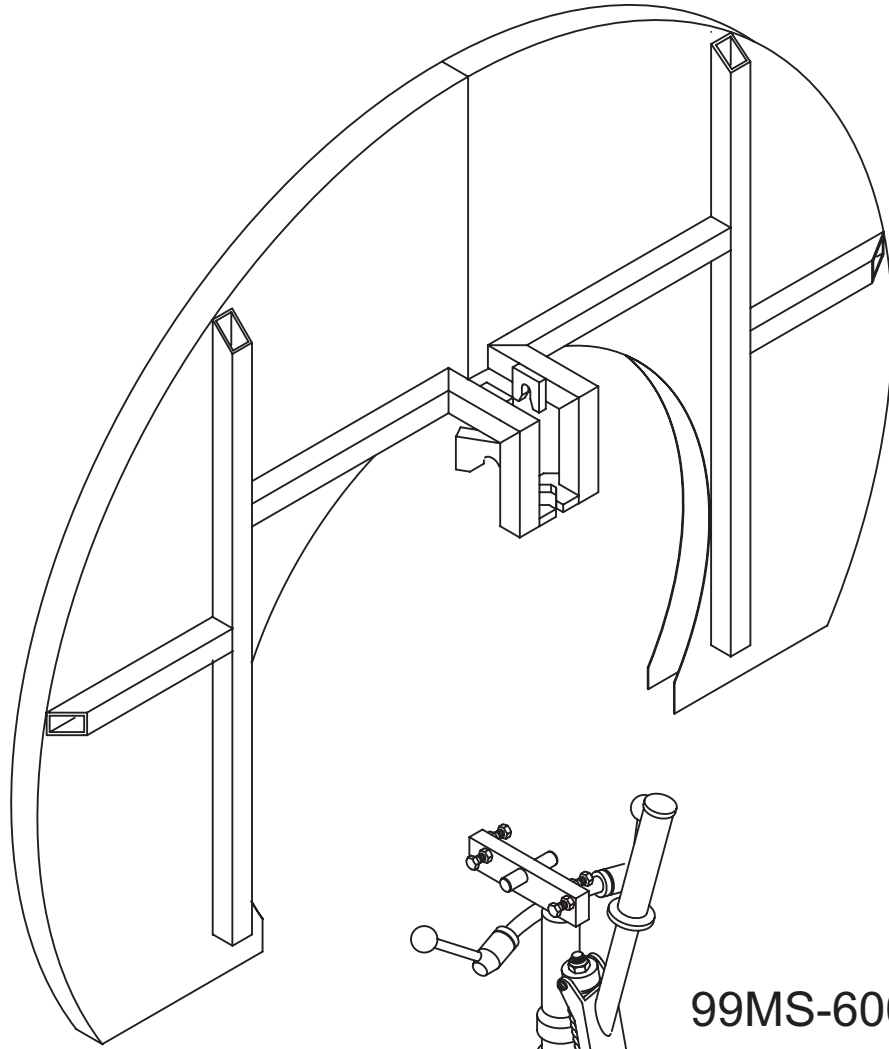

Ø 1380 99MS-54573-01 / 977618
Ø 1600 99MS-54348-01 / 977606
Ø 2200 99MS-54392-00 / 976184

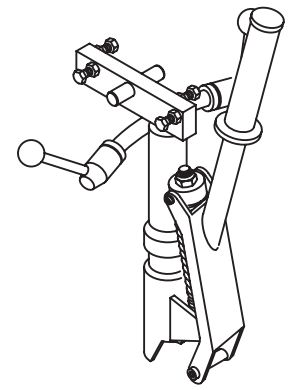

99MS-60055-01 / 977334

