

Operating Instructions ***Spare Parts List***

Drive Unit PPH20**

Index 003

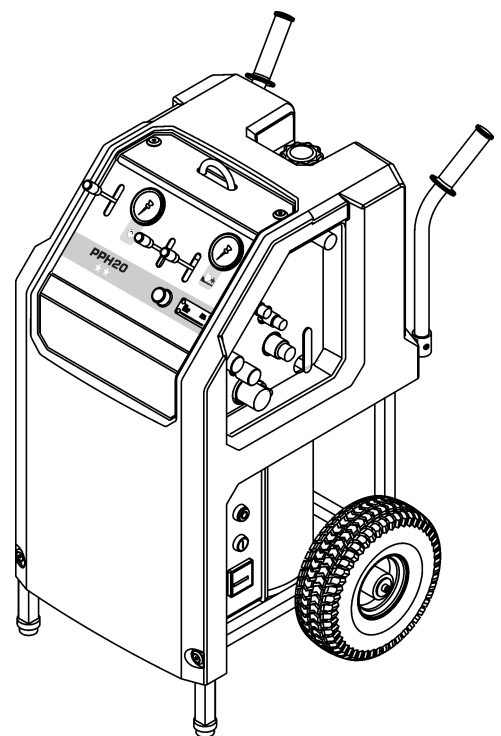

Manufacturer's address:

TYROLIT Hydrostress AG
Witzbergstrasse 18
CH-8330 Pfäffikon
Switzerland
Phone +41 (0) 44 / 952 18 18
Fax +41 (0) 44 / 952 18 00

TYROLIT Hydrostress AG reserves the right to make technical changes without prior notice.

Copyright © 2007 TYROLIT Hydrostress AG, CH-8330 Pfäffikon ZH

All rights reserved, in particular the copying and translation rights.

The reprinting of these Operating Instructions, including extracts, is prohibited. No part of these Operating Instructions may be reproduced in any form whatsoever or be processed, copied or distributed using electronic systems without the written permission of TYROLIT Hydrostress AG.

Overview

	Page
0 Introduction	1
0.1 Congratulations!- - - - -	1
0.2 Validity of these Operating Instructions - - - - -	2
0.3 Standards - - - - -	2
0.4 Delimitation of the system - - - - -	2
1 Product description	1
1.1 Application - - - - -	1
1.2 Safety measures - - - - -	1
1.3 Operating instructions for connectable equipment - - - - -	1
1.4 Name plate - - - - -	1
1.5 Information sign - - - - -	2
1.6 EC Declaration of Conformity - - - - -	3
1.7 Technical data - - - - -	4
1.8 Hydraulics - - - - -	5
1.9 Electrical equipment - - - - -	6
1.10 Water - - - - -	7
1.11 Noise exposure (noise level) - - - - -	7
1.12 Scope of supply - - - - -	7
2 Safety instructions	1
2.1 General- - - - -	1
2.2 General safety rules - - - - -	1
2.3 Safety principles - - - - -	2
2.4 Responsibility - - - - -	3
2.5 Generally applicable warnings of residual dangers - - - - -	5
3 Design and function	1
3.1 Design - - - - -	1
3.2 Function - - - - -	2
4 Controls and displays	1
4.1 Controls - - - - -	1
4.2 Electric controls - - - - -	2
4.3 Displays - - - - -	3
5 Operation	1
5.1 Personnel qualifications - - - - -	1
5.2 System requirements - - - - -	1
5.3 Preparatory operations - - - - -	2
5.4 Working - - - - -	5
5.5 After the work - - - - -	8
6 Servicing	1
6.1 Servicing and maintenance table- - - - -	1
7 Corrective maintenance	1
7.1 Troubleshooting - - - - -	1
7.2 Storage- - - - -	3

8	Transport	1
8.1	Transport - - - - -	1
8.2	Safety instructions - - - - -	1
8.3	Crane suspension shackle and transport handle - - - - -	2
9	Disposal	1
9.1	General - - - - -	1
9.2	Disposal regulations - - - - -	2
9.3	Disposal of the Drive Unit PPH20** - - - - -	2

0 Introduction

0.1 Congratulations!

You have decided to purchase a tried and tested TYROLIT Hydrostress AG system and have thus acquired a highly sophisticated and reliable state-of-the-art unit.

Thanks to the emphasis we place on quality assurance, your TYROLIT Hydrostress AG system is another top-of-the-range Swiss product:

- High performance
- Reliable operation
- High portability
- Easy handling
- Low maintenance costs

Only original TYROLIT Hydrostress AG spare parts can guarantee quality and interchangeability.

In the case of neglected or inappropriate maintenance, we will be unable to accept the warranty commitment as specified in our terms of delivery.

Any repair work must be carried out by trained personnel only.

If you need more details about how to keep your TYROLIT Hydrostress AG system in perfect condition, please contact our after-sales service for further information.

We hope that working with your TYROLIT Hydrostress AG system will be a problem-free and fault-free experience.

TYROLIT Hydrostress AG

Management

Copyright © TYROLIT Hydrostress AG, May 2007

TYROLIT Hydrostress AG
Witzbergstrasse 18
CH-8330 Pfäffikon
Switzerland
Phone +41 (0) 44 / 952 18 18
Fax +41 (0) 44 / 952 18 00

0.2 Validity of these Operating Instructions

This manual is only valid for the following system:

Drive Unit PPH20**

0.3 Standards

These Operating Instructions have been prepared in accordance with the CE Machinery Directive Appendix I and with the relevant standards in force at the time of printing.

0.4 Delimitation of the system

These Operating Instructions describe the use of the **Drive Unit PPH20****.

1 Product description

1.1 Application

The Drive Unit PPH20** has been designed as a component for the following concrete processing systems:

- Hydraulic wall saw systems
- Hydraulic diamond wire saw systems
- Hydraulic core drilling systems
- Hydraulic chainsaws

The applicable mandatory limitations on use and other parameters are contained in Chapter 1 "Technical data" 1.7, 1-4

1.2 Safety measures

Any use other than for the intended purpose (see Chapter 1.1, 1-1) constitutes abuse or misuse.

1.3 Operating instructions for connectable equipment

In order to ensure safety in the workplace and in danger areas, as well as the safe operation of connectable equipment, the relevant Operating Instructions must in all cases be followed.

1.4 Name plate

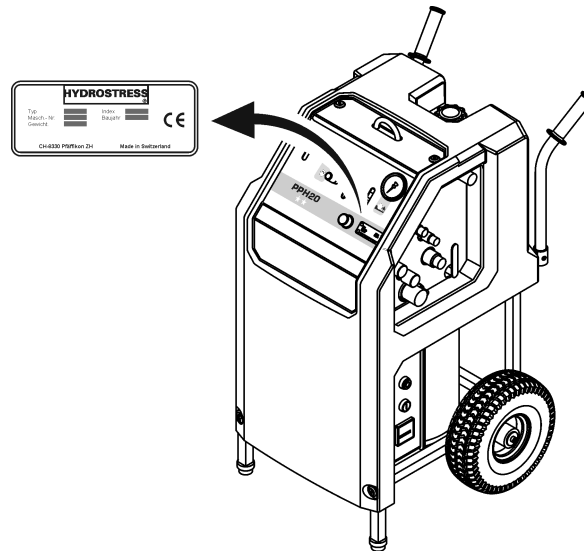





Fig. 1-1 Name plate

1.5 Information sign

Attached to the plastic hood is an information sign containing the following information:

- Hose connections
(For a description see "Chapter 5" 5.3.2.1,  5-2)
- Pressure stages
(For a description see "Chapter 5" 5.4.2,  5-6)
- Risk of frost
(For a description see "Chapter 6" 6.1.1,  6-2)
- Hydraulic oil
(For a description see "Chapter 6" 6.1.2.1,  6-2)

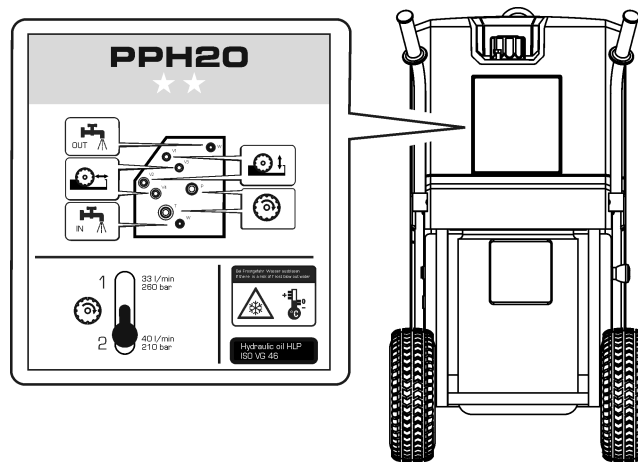

Fig. 1-2 Information sign

1.6 EC Declaration of Conformity

Description	Hydraulic drive unit
Type designation	Drive Unit PPH20**
Year of construction	2007

We declare under our own liability that this product complies with the following directives and standards:

1.6.0.1 Directive applied:

Machinery Directives 2006/42/EC
EC Low Voltage Directives 73/23/EC
EN 2002/96/EG Waste electrical and electronic equipment

1.6.0.2 Standards applied:

EN 12100-1 Safety of machinery – Basic concepts, general design
EN 12100-2 principles
EN 294 Safety of machinery – Safety distances to prevent upper limbs reaching danger areas
EN 349 Safety of machinery – Safety distances to avoid crushing of body parts
EN 982 Safety of machinery
Safety requirements of safety systems and their components - Hydraulics
EN 60204-1 Safety of machinery - Electrical equipment of machines

1.7 Technical data

1.7.1 Dimensions

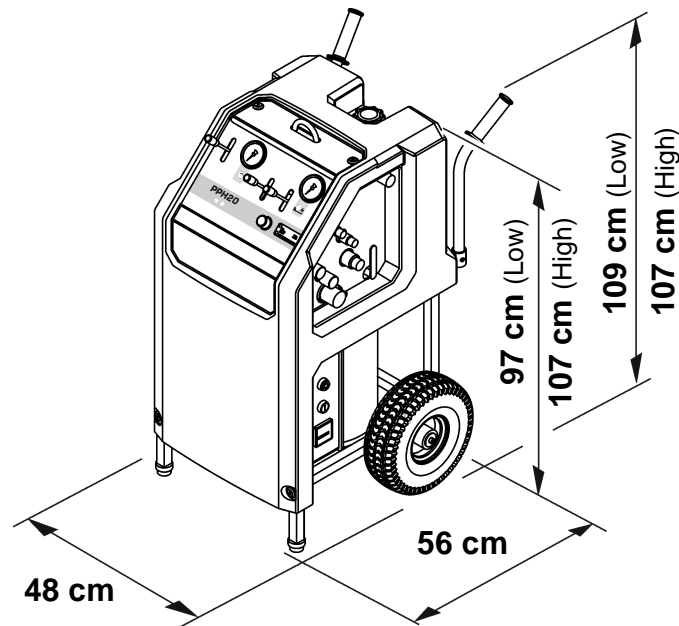

Fig. 1-3 Dimensions

1.7.2 Weight

Operating weight	145 kg	380-420V / 50Hz (Low)
	172 kg	380-420V / 50Hz (High)
	148 kg	440-480V / 60Hz (Low)
	153 kg	200-240V / 60Hz (Low)

1.7.3 Tyres

Wheel Ø 30 cm

Operating pressure 3 bar

1.8 Hydraulics

1.8.1 Main circuit

Main circuit 2 pumps

Flow rates can be set to 33 / 40 l/min., depending on the cutting tool speed required

Flow rates and pressures

Stage I	33 l/min	260 bar	
Stage II	40 l/min	190 bar	(Low)
Stage II	40 l/min	210 bar	(High)

Same power in all stages

1.8.2 Feed circuits

Feed circuits: 1 pump

Two hydraulic feed outputs which can be regulated independently of each other.

1.8.3 Oil tank

Oil tank volume: 6 litres

Filter quality: 20 µm

1.8.4 Return oil filter

Type: Tank-mounted filter

1.8.5 Oil cooling

Oil cooler: Water/oil heat exchanger

1.8.6 Couplings and hoses

Plug-in couplings	Type FD and FF, non-drip
Hoses	Length 8m (filled with hydraulic oil)

1.8.7 Oil quality

TYROLIT Hydrostress AG recommends:

Hydraulic oil: HLP / ISO VG 46

1.9 Electrical equipment



Information

Electrical data are only valid for the installed loads
3 P / PE 400 VAC / 50 Hz

1.9.1 Different voltages

For countries where different mains networks operate the following types are available:

Drive Unit PPH20**	380-420 V	50 Hz
Drive Unit PPH20**	440-480 V	60 Hz
Drive Unit PPH20**	200-240 V	60 Hz



Warning

A danger will arise if the Drive Unit PPH20 is operated with a different mains network voltage.**

The details on the name plate must correspond to the mains network values (voltage and frequency).

Damage may be caused to the unit if it is connected to a different voltage; there is also a risk of fire and personal injury.

1.9.2 Motor

Electric motor	air-cooled	
Power supply	3 P / PE 380 - 420 V / 50 Hz	
	440 - 480 V / 60 Hz	
Current consumption	380 - 420 V / 50 Hz	32 A
	440 - 480 V / 60 Hz	29 A
	200 - 240 V / 60 Hz	58 A
Output	20 kW	
Speed	at 50 Hz 2900 rpm	
	at 60 Hz 3480 rpm	

1.9.2.1 Motor protection

Thermal protection	Winding thermostat
Electrical protection	Thermal relay

1.9.2.2 Motor cooling

Air cooling

1.9.2.3 Protection class

IP 55

1.10 Water

Pressure min. 2 bar to max. 6 bar
Quantity min. 6 l/min at max 25°C

1.11 Noise exposure (noise level)

Depending on the working environment and the connected device, the Drive Unit PPH20** can produce high noise levels during operation.



Danger

Noise danger

When operating the PPH20** drive unit, the wearing of hearing protection is mandatory at all times.

If this instruction is not followed irreparable hearing damage may result.

1.11.0.1 Noise level measurement

Noise level measured at the ear of the operator 0.5 m from the Drive Unit PPH20**; noise power level according to ISO 3744; drive unit only; highest value taken from all operating states at full load; mean values from three series of measurements.

Noise level 83 dB (A) noise power level 92 dB (A)

1.12 Scope of supply

- Drive Unit PPH20**
- Operating Instructions / Spare parts list

2 Safety instructions

2.1 General

All persons who work on and with the Drive Unit PPH20** have a duty to read and understand the Operating Instructions.

2.1.1 Observance of the safety instructions

The Drive Unit PPH20** has been inspected before being shipped and is delivered in perfect condition. TYROLIT Hydrostress AG does not accept any liability for damage which is caused by failure to observe the instructions and information provided in the Operating Instructions. This applies in particular to:

- Damage caused by improper use and operator error.
- Damage caused by failure to observe safety-related information in the Operating Instructions or shown on the warning signs attached to the machine.
- Damage caused by defective or neglected maintenance work.

Independently performed conversions and alterations may affect safety and are not permitted.

2.2 General safety rules

2.2.1 Statutory provisions

The generally applicable national and local safety and accident prevention provisions and the supplementary operator regulations must be followed and complied with.

2.2.2 Inspection and maintenance obligation

The operator is under an obligation to use the Drive Unit PPH20** only when it is in a perfect and undamaged condition. The maintenance intervals shown in the Operating Instructions must be adhered to without fail. Malfunctions and mechanical damage must be rectified without delay.

2.2.3 Spare parts

Only TYROLIT Hydrostress AG original spare parts may be used. Otherwise, damage can be caused to the Drive Unit PPH20** or other property and may result in personal injury.

2.2.4 Power connections

The Drive Unit PPH20** must be connected and coupled in accordance with the Operating Instructions.

2.3 Safety principles

2.3.1 Delimitation of the safety concept

The Drive Unit PPH20** does not affect the safety concept of the connected systems, equipment and installations.

2.3.2 Safety elements

Protection from live electrical parts

All functional units containing parts which carry hazardous voltages are shock-protected by suitable covers.

2.3.3 Removal of protective devices

Protective devices may only be removed if the unit has been switched off, disconnected from the mains and is at standstill. Safety components, in particular, may only be removed and refitted by authorised personnel, see "Chapter 2" 2.4.1, 2-3.

Before switching the Drive Unit PPH20** back on again, the safety elements must be checked to ensure correct operation.

2.3.4 Safety measures (organisational)

2.3.4.1 Product monitoring obligation

Operating personnel must notify changes in operational behaviour or safety-related components to a responsible person or the manufacturer, immediately.

2.3.4.2 Location of the Operating Instructions

A copy of the Operating Instructions must be available to staff at all times at the place of use of the equipment.

2.4 Responsibility

2.4.1 Authorised personnel

Work on or with the TYROLIT Hydrostress AG machines or systems may only be performed by authorised personnel. Personnel are considered by TYROLIT Hydrostress AG to be authorised if they meet the necessary training and know-how requirements and they have been assigned a precise functional role.

The personnel qualifications for the corresponding work are contained in the introduction under "General" of the respective chapters.

2.4.2 Manufacturer

TYROLIT Hydrostress AG or a company expressly nominated by TYROLIT Hydrostress AG is deemed to be the manufacturer of the products supplied by TYROLIT Hydrostress AG. Within the context of an integrated quality and safety control system, the manufacturer is entitled to request from the operator information about the products.

2.4.3 Operator (owner)

The operator named by TYROLIT Hydrostress AG is the primary, legal entity responsible for the correct use of the product and for the training and assignment of the authorised personnel. The operator sets out the mandatory skills and level of training of the authorised personnel for his company.

2.4.4 Operator (user)

User is the term employed by TYROLIT Hydrostress AG to designate a person who independently performs the following work:

- Sets up TYROLIT Hydrostress AG machines or systems for tasks according to the intended purpose.
- Performs tasks independently and monitors these.
- Locates malfunctions and initiates or performs troubleshooting.
- Carries out servicing and simple maintenance.
- Monitors the correct functioning of the safety devices.

2.4.5 Service engineer

Service engineer is a term used by TYROLIT Hydrostress AG to designate a person who independently performs the following work:

- Installs TYROLIT Hydrostress AG machines and systems and controls their correct application.
- Makes adjustments to machines and systems for which special access rights are required.
- Performs repairs, complex service work and maintenance work.

2.4.6 Qualification and training

2.4.6.1 Operator (owner)

- A technically trained person in a management position.
- Has relevant experience in personnel management and danger assessment.
- Has read and understood the "Safety instructions" chapter.

2.4.6.2 Operator (user)

- Has trained as a concrete cutting expert or has professional experience.
- Has received an introduction (basic training) to the operation of the TYROLIT Hydrostress AG machines and systems from a service engineer.
- Has read and understood Chapter 2 "Safety instructions".

2.4.6.3 Service engineer

- Has specialist professional training (mechanical / electrotechnical).
- Has attended specialist courses at TYROLIT Hydrostress AG.
- Has read and understood the "Safety instructions" chapter.

2.5 Generally applicable warnings of residual dangers



Danger

Electric shock due to defective electronic equipment.

The electrotechnical equipment must be checked prior to each use and from time to time during prolonged use. Defective parts, such as e.g. cables and plugs, must be replaced immediately in the de-energized state by electrotechnically trained personnel.

Failure to comply with this regulation may lead to serious physical injury or death. Secondary damage such as fires may also occur.



Warning

Danger of allergic reactions if skin comes into contact with hydraulic oil.

Persons who have an allergic reaction to hydraulic oil must wear protective gloves and goggles when carrying out work where they come into contact with hydraulic oil. Any areas of the skin affected must be rinsed immediately with copious amounts of water.

Failure to observe this regulation may result in allergic reactions or injury to the eyes.

3 Design and function

3.1 Design

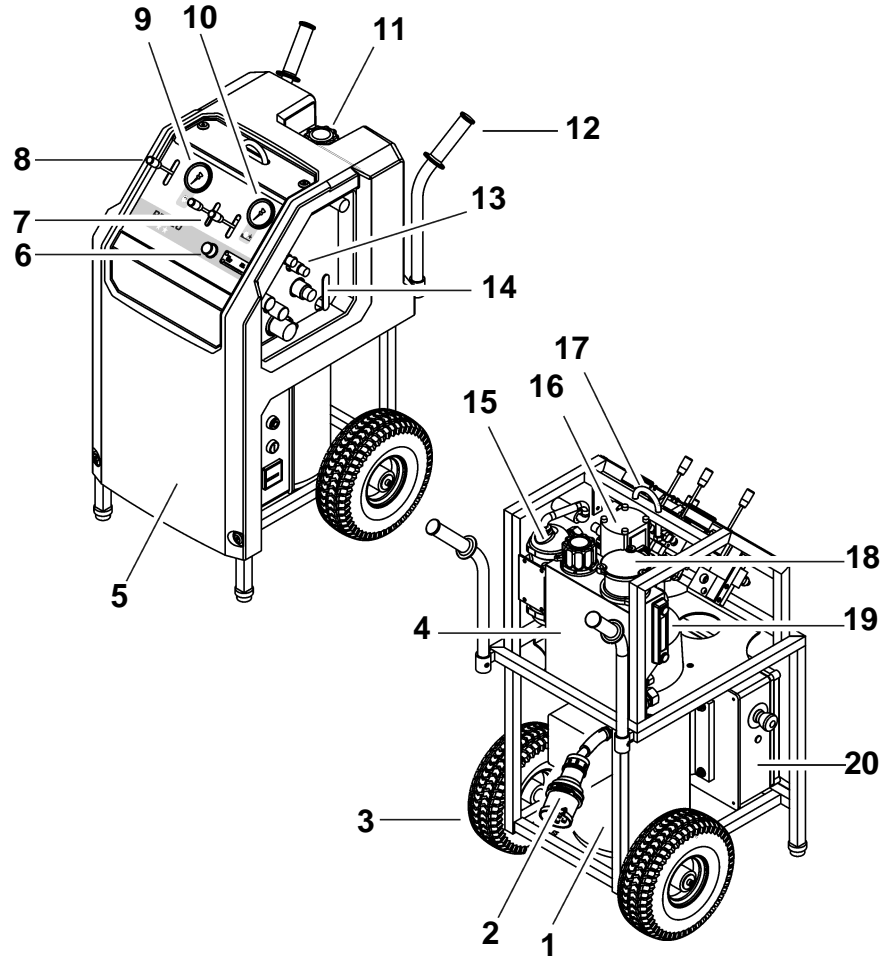

Fig. 3-1 Components

- | | |
|---|-----------------------------|
| 1 Electric motor | 11 Oil filler neck |
| 2 Electrical connection | 12 Transport handle |
| 3 Wheel | 13 Coupling connector piece |
| 4 Oil tank | 14 Water valve |
| 5 Hood | 15 Oil cooler |
| 6 Pressure control of feed motors | 16 Pump assembly |
| 7 Direction selector lever of feed motors | 17 Suspension shackle |
| 8 Pressure stage selector lever of main motor | 18 Oil filter |
| 9 Pressure gauge of main motor | 19 Oil level indicator |
| 10 Pressure gauge of feed motors | 20 Electrical box |

3.2 Function

3.2.1 Hydraulic circuit diagram

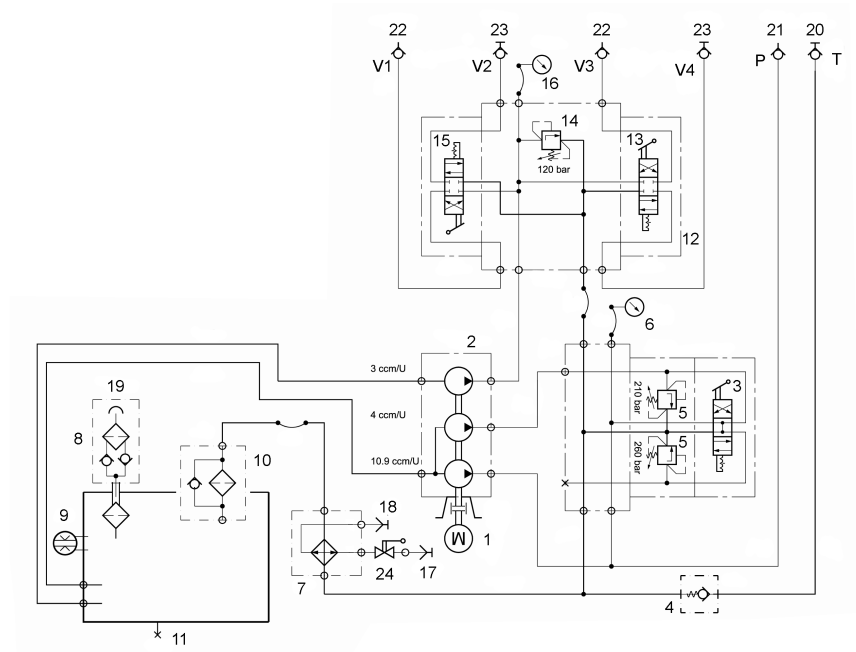

Fig. 3-2 Hydraulic circuit diagram

- | | | | |
|----|--------------------------|----|--------------------------|
| 1 | Electric motor | 14 | Pressure control valve |
| 2 | Pump assembly | 15 | Distributing regulator |
| 3 | Control valve | 16 | Pressure gauge 0-250 bar |
| 4 | Check valve | 17 | Nipple |
| 5 | Pressure relief valve | 18 | Coupling |
| 6 | Pressure gauge 0-400 bar | 19 | Tank cover |
| 7 | Oil-water cooler | 20 | Coupling |
| 8 | Aeration filter | 21 | Nipple |
| 9 | Oil level | 22 | Nipple |
| 10 | Return filter | 23 | Coupling |
| 11 | Screw plug | 24 | Water valve |
| 12 | Control valve | | |
| 13 | Distributing regulator | | |

3.2.2 Wiring diagram

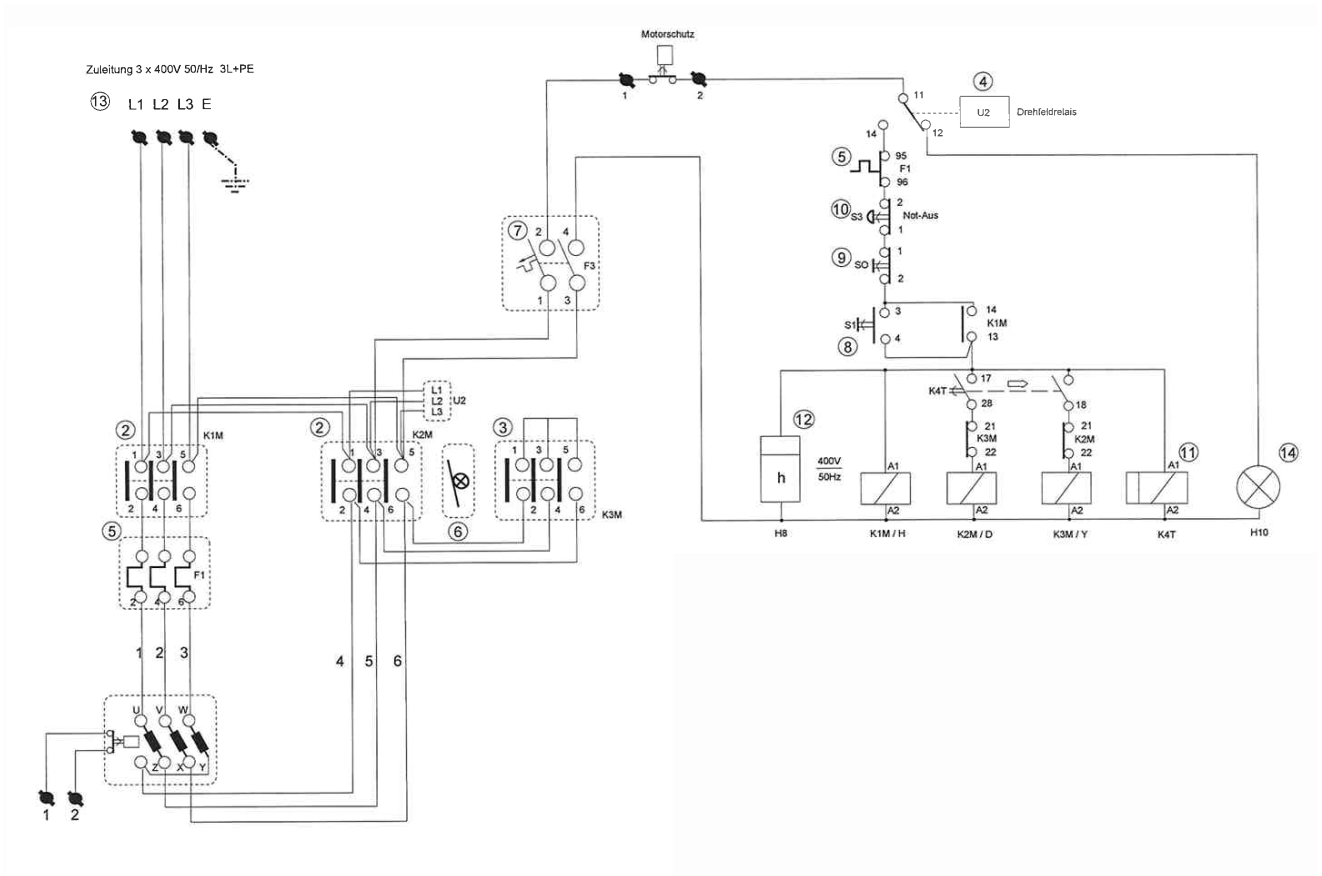

Fig. 3-3 Wiring diagram

- | | |
|------------------------|-------------------|
| 1 Elec. box | 9 Pushbutton |
| 2 Contactor | 10 EMERG. STOP |
| 3 Contactor | 11 Time relay |
| 4 Phase sequence relay | 12a Rotation lock |
| 5 Thermal relay | 12b Hour counter |
| 6 Interlock | 13 Plug CEE 32/5 |
| 7 Circuit breaker | 14 Pilot lamp |
| 8 Pushbutton | |

4 Controls and displays

4.1 Controls

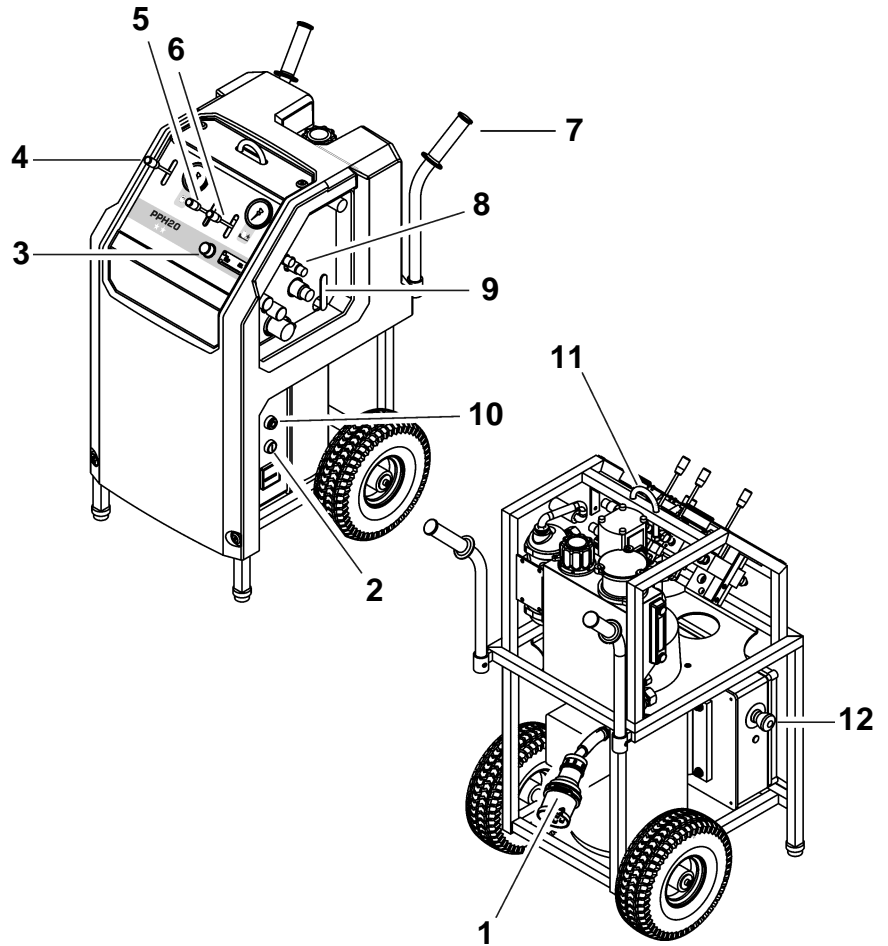

Fig. 4-1 Controls

- | | | | |
|---|---|----|-------------------------------|
| 1 | Current phase reversing plug | 8 | Water and hydraulic couplings |
| 2 | Start button | 9 | Water valve |
| 3 | Pressure regulation of feed motors | 10 | Off switch |
| 4 | Pressure stage selector lever of main motor | 11 | Suspension shackle |
| 5 | Direction selector lever of feed motor | 12 | EMERG. STOP |
| 6 | Direction selector lever of feed motor | | |
| 7 | Transport handle | | |

4.2 Electric controls

4.2.1 Current phase reversing plug / Forward/reverse switch

If the phase position of the power supply to the site is wrong, the phases can be turned.

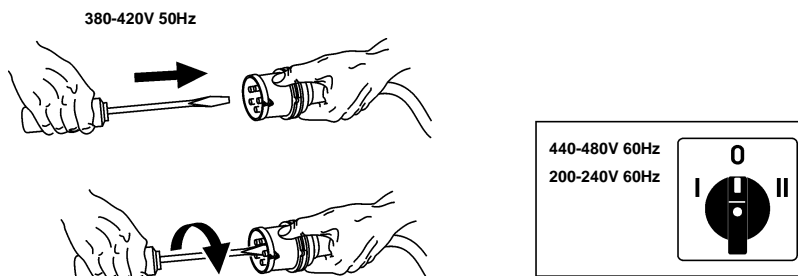

Fig. 4-2 Current phase reversing plug

4.2.2 EMERGENCY STOP

Pressing the EMERGENCY STOP button switches the system off and prevents the system being accidentally switched on again.

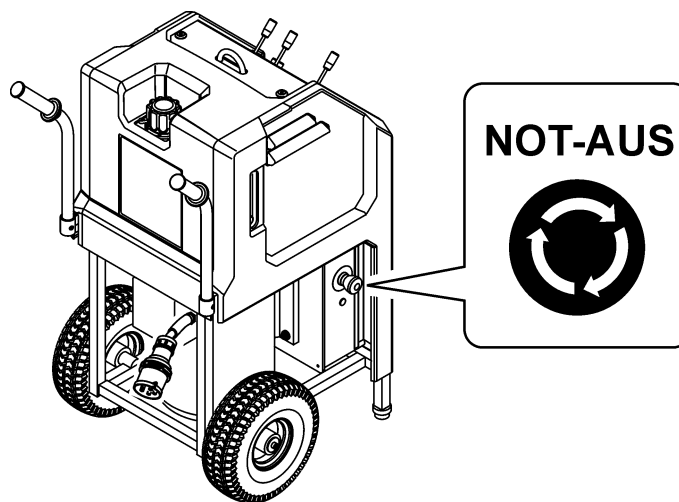

Fig. 4-3 EMERGENCY STOP

4.3 Displays

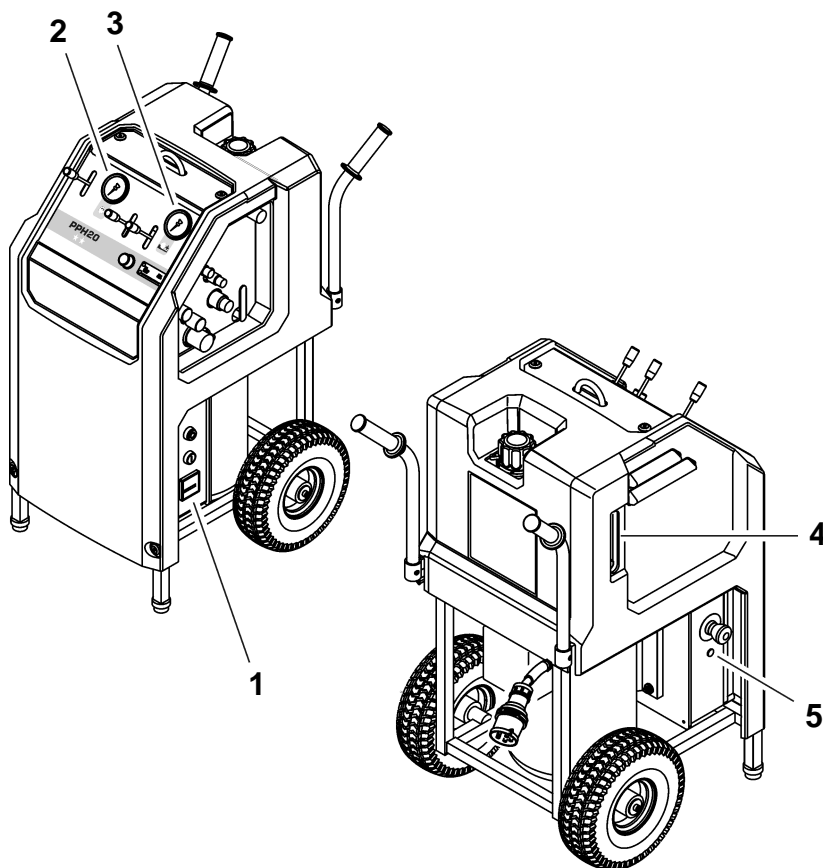

Fig. 4-4 Displays

- | | |
|---------------------------------|----------------------------|
| 1 Hour counter | 4 Oil level indicator |
| 2 Pressure gauge of main motor | 5 Current phase pilot lamp |
| 3 Pressure gauge of feed motors | |

4.3.1 Hour counter

The hour counter allows for precise observance of the service intervals.

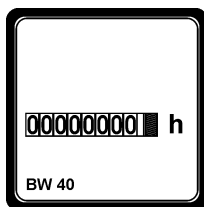

Fig. 4-5 Hour counter

4.3.2 Pressure gauge

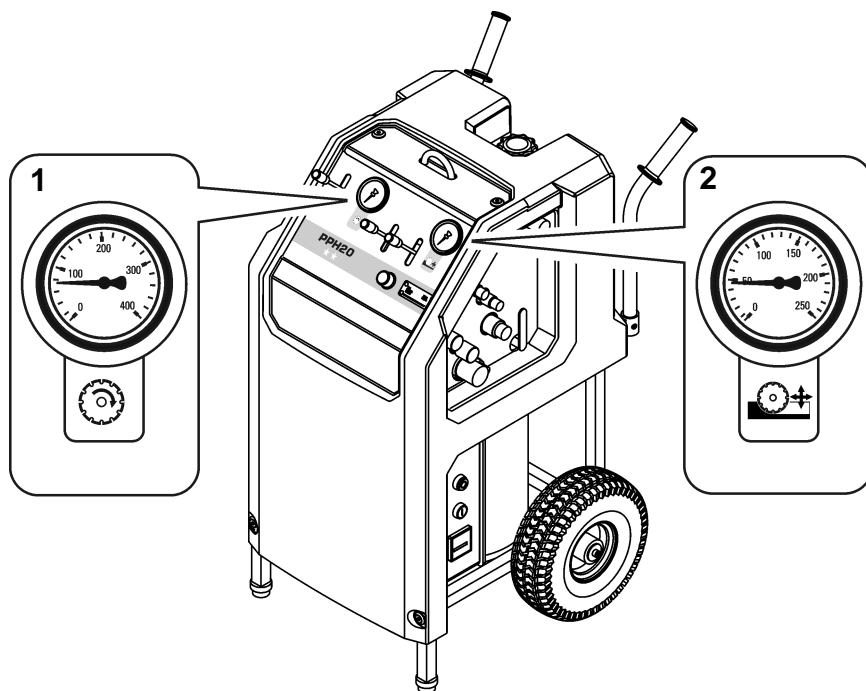

Fig. 4-6 Pressure gauge

- 1 Pressure gauge for main motor (0 bar to 400 bar)
- 2 Pressure gauge for feed motors (0 bar to 250 bar)

4.3.3 Oil level indicator

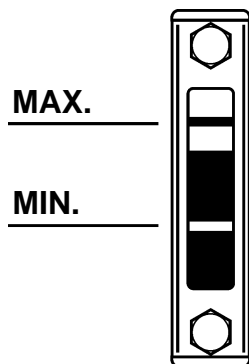

Fig. 4-7 Oil level indicator

Information



The quantity of oil between oil MIN and oil MAX is 1.5 litres.

Different types of hydraulic oil should not be mixed together, otherwise the oil will age prematurely.

Recommended hydraulic oil: HLP / ISO VG 46

5 Operation

5.1 Personnel qualifications

The Drive Unit PPH20** must not be operated by unauthorised personnel. Personnel are only authorised if they meet the following requirements.

- Have trained as a concrete cutting expert or have professional experience.
- Have received an introduction (basic training) to the operation of the Drive Unit PPH20** from a service engineer.
- Have read and understood chapter 2 "Safety instructions".

5.2 System requirements



Warning

A danger will arise if the Drive Unit PPH20 is operated with a different mains network voltage.**

The details on the name plate must correspond to the mains network values (voltage and frequency).

The system may be damaged by connecting it to a different voltage. There is also a danger of fire and injury.

5.2.1 Connectable equipment

All hydraulic units that are designed for the pressure and delivery volume of the Drive Unit PPH20**. (see "Chapter 1" 1.8, 1-5)



Information

The Drive Unit PPH20** is one of a series of drive products available from TYROLIT Hydrostress AG.

In order to allow expansion of your Drive Unit PPH20** with suitable devices to create an hydraulic saw or drilling system with optimum performance, please talk to TYROLIT Hydrostress AG.

5.3 Preparatory operations

5.3.1 Visual inspection

Before starting work always complete the following visual inspections:

- Is the power supply earthed and fitted with a residual current circuit breaker?
- Does the mains network have the correct fuse protection?

Design	Fuse protection	Cable cross section
380 - 420 V / 50Hz	32 A	5x6 mm ² (from 25 to 50 m 5x10 mm ²)
420 - 480 V / 60 Hz	32 A	5x6 mm ² (from 25 to 50 m 5x10 mm ²)
200 - 240 V / 60 Hz	63 A	5x10 mm ² (from 25 to 50 m 5x16 mm ²)

- Is the water line properly connected to the Drive Unit PPH20**?



Information
Ensure that the water supply is not interrupted while work is in progress.

- Is there sufficient oil in the Drive Unit PPH20**?
- Is there any damage to cables or plugs?
- Has the EMERGENCY STOP been reset?

5.3.2 Connecting the Drive Unit PPH20**

5.3.2.1 Connecting the hoses



Warning
<p>Danger from uncontrolled movements and uncontrolled escape of oil!</p> <p>Never connect or disconnect hoses while the drive unit is running!</p> <p>Failure to observe this regulation may result in cut wounds or injury to body parts as well as damage to property.</p>

5.3.2.2 Hose connections

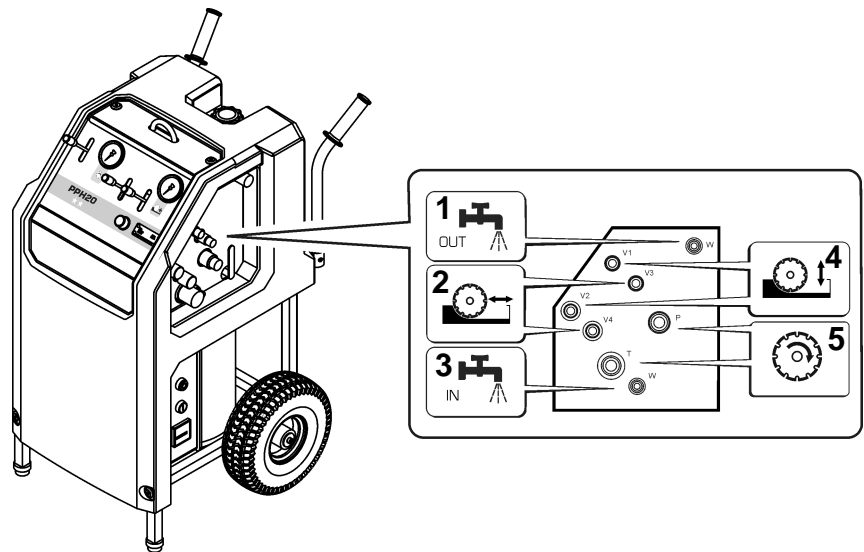

Fig. 5-1 Hose connections

- 1 Water connection OUT
- 2 Couplings of feed motor 1
- 3 Water connection IN
- 4 Couplings of feed motor 2
- 5 Main motor couplings

Proceed as follows:

- Visual inspection
 - Check:
 - Oil leaks from hoses and couplings
 - Couplings for damage and contamination
 - Hoses for damage
- Push the hose coupling on to its counterpart until you hear it "click"
- Twist the locking ring of the coupling

Information

If hoses cannot be connected or this cannot be done easily, they are under pressure. Release pressure in hoses via the pressure relief device. Release pressure in the Drive Unit PPH20**, see "Chapter 5" 5.3.2.3, 5-3.

Never use force to connect couplings!

5.3.2.3 Release pressure in the Drive Unit PPH20**

Proceed as follows:

- Push the feed lever to one of the limit positions

5.3.3 EMERGENCY STOP

In danger situations the EMERGENCY STOP button must be pressed immediately.

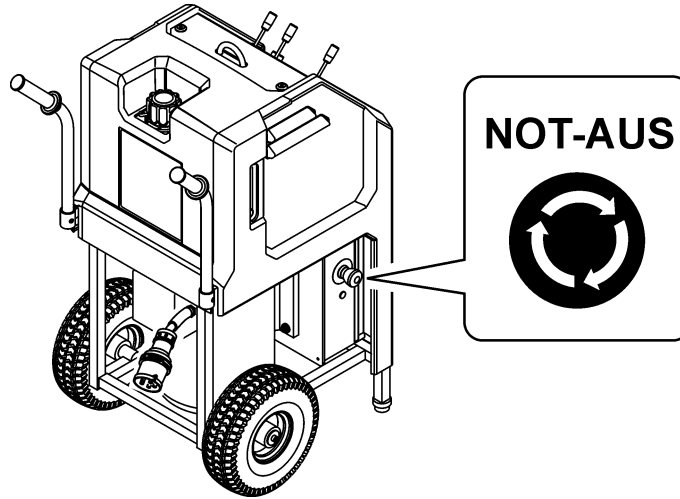

Fig. 5-2 EMERGENCY STOP



Information

Deactivating EMERG. STOP:
The EMERG. STOP is deactivated by turning it clockwise.

5.4 Working

5.4.1 Starting the Drive Unit PPH20**



Information

The Drive Unit PPH20** should only be switched on in a level and up-right position.

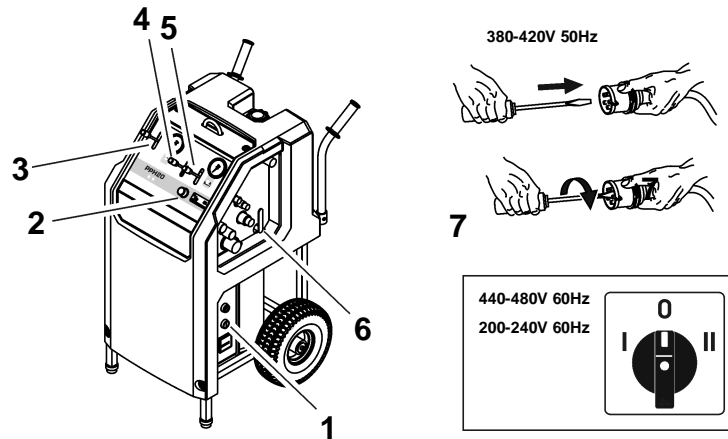

Fig. 5-3 Starting the Drive Unit PPH20**

- 1 Start button
- 2 Pressure control valve of feed
- 3 Pressure stage selector lever of main motor
- 4 Direction selector lever of feed 1
- 5 Direction selector lever of feed 2
- 6 Water valve
- 7 Current phase reversing plug / Forward/reverse switch

- Check that the EMERG. STOP on the Drive Unit PPH20** is deactivated.
- Push the pressure stage selector lever (3) to the 0 position
- Push the direction selector levers (4 / 5) to the 0 position
- Turn the rotary selector of the pressure control valve (2) to the 0 position
- Open the water valve (6)
 - Water emerges from the cutting tool
- Press the start button (1)
- The electric motor starts up; the Drive Unit PPH20** is ready for operation



Information

If the electric motor does not start but the phase pilot lamp lights up, the direction of rotation on the current phase reversing plug 7 must be turned.

5.4.2 Selecting the pressure stage of the main circuit

Once the Drive Unit PPH20** has been started properly, the pressure stage can be selected.

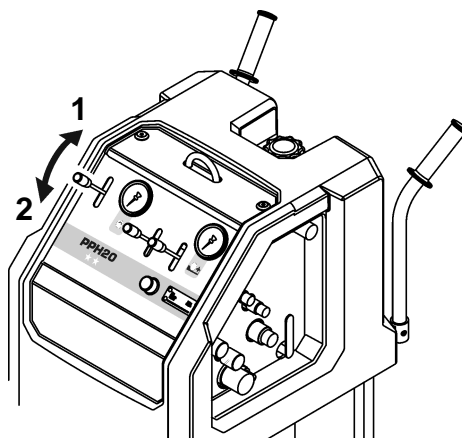

Fig. 5-4 Selecting the pressure stage

Pressure stage 1 33 l/min 260 bar
 Pressure stage 2 40 l/min 210 bar (High)
 Pressure stage 2 40 l/min 190 bar (Low)



Information

On the Drive Unit PPH20**, two fixed pressure stages can be selected for the main circuit. The pressure stages cannot be regulated.



Information

The pressure stages can be freely changed and selected during the work operation. When changing the pressure stage, the cutting tools should not be under load.
 To ensure the optimal tool speeds, the data for the relevant connected devices must be taken into consideration.

5.4.3 Feed movements

The feed movements can only be controlled individually by means of the two feed levers.

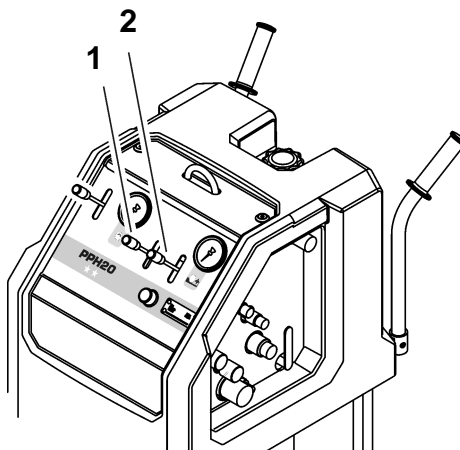

Fig. 5-5 Feed

- 1 Direction selector lever (travel feed)
- 2 Direction selector lever (swivel feed)

5.4.3.1 Feed power

The feed power can be adjusted by means of a rotating handle.

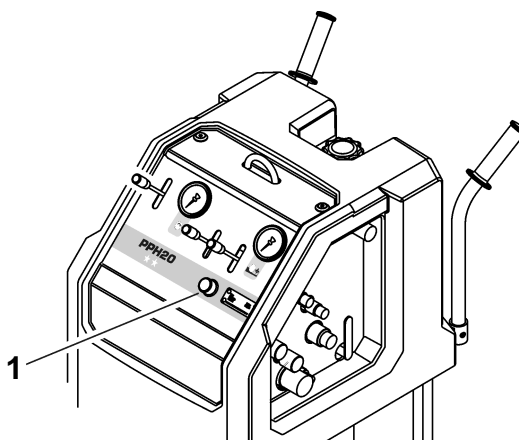

Fig. 5-6 Pressure control valve

- 1 Rotating handle for regulating the power

5.4.4 Shutting down the Drive Unit PPH20**

Proceed as follows:

- Push the pressure stage selector lever to the 0 position
- Push the direction selector levers of the feeds to the 0 position
- Turn the rotary handle of the pressure control valve to the 0 position
- Switching off the Drive Unit PPH20** by means of the Off button (EMERG. STOP)
- Close the water valve on the Drive Unit PPH20**

5.5 After the work

Proceed as follows:

- Unplug the mains plug (Drive Unit PPH20**)
- Uncouple the water supply on the Drive Unit PPH20**
- Open the water valve on the Drive Unit PPH20**
- Uncouple the hydraulic hoses
- Clean the Drive Unit PPH20** with water



Information

In order to avoid frost damage, if there is a danger of frost the entire water system must be emptied on finishing work or prior to extended breaks in the work.

6 Servicing

6.1 Servicing and maintenance table

		Before each start-up	Upon completion of work	Weekly	Annually	In the event of malfunction	In the event of damage
Hydraulic system	Hydraulic hose inspection (leakproof condition / cleanliness)	X	X			X	X
	Coupling inspection (leakproof condition / cleanliness)	X	X			X	X
	Check oil level, see "Chapter 4" 4.3.3, 4-4	X	X			X	
	Replace hydraulic oil, see "Chapter 6" 6.1.2, 6-2					X	
Water economy	Water line (leakproof condition / cleanliness)	X	X			X	X
	If there is a risk of frost, blow out the water, see "Chapter 6" 6.1.1, 6-2		X				
Mechanical	Retighten accessible screws and nuts			X		X	
Major service First service after 100 operating hours After every 200 operating hours, thereafter	May only be carried out by TYROLIT Hydrostress AG or an authorised representative						

6.1.1 Blowing out the water



Information	
In order to prevent damage from frost-cracks, if there is a risk of frost or prior to extended breaks in work the cooling water must be blown out of the system.	

6.1.2 Oil change

6.1.2.1 Oil quality

TYROLIT Hydrostress AG recommends:

Hydraulic oil: HLP / ISO VG 46

Other hydraulic oils can be used if they comply with the following specifications:

Pour point:	-42°C
Viscosity index	170
Viscosity class:	HLP VG 46 or ISO 3498 HV 46
Wear-protection according to DIN 51524 Part 3 (HV46)	



Information	
Different types of hydraulic oil should not be mixed together, otherwise the oil will age prematurely.	

6.1.2.2 Replacing hydraulic oil

In order to replace the hydraulic oil you will need:

- A collecting pan for the used hydraulic oil with a capacity of approx. 15 litres
- Open-ended spanner, size across flats 18 mm for the oil drain plug
- Approx. 6 litres of hydraulic oil

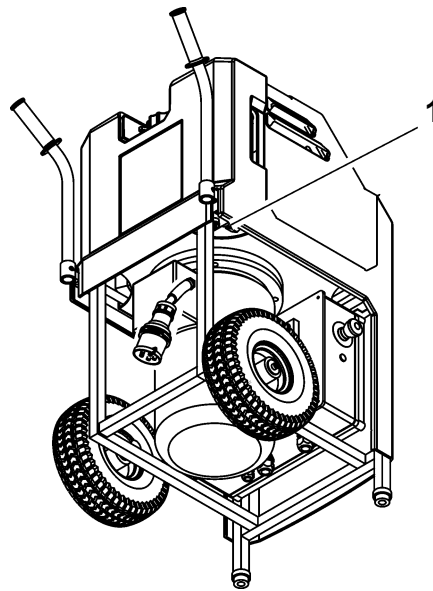

Fig. 6-1 Replacing hydraulic oil

1 Oil drain plug

Proceed as follows:

- Place the collecting pan below the oil drain plug (1)
- Open tank cover
- Remove oil drain plug (1)
- Drain hydraulic oil completely
- Screw in oil drain plug (1)
- Fill tank with new hydraulic oil
- Bleeding the system
- Close the tank cover
- Dispose of waste hydraulic oil in accordance with local regulations

Bleeding the system**Information**

Air must be bled from the system whenever the tank has been completely emptied and refilled.

Proceed as follows:

- Open tank cover
- Fill oil to maximum mark
- Do not refit the tank cover, yet
- Short-circuit the main circuit with hose
- Start the Drive Unit PPH20**, see "Chapter 5" 5.4.1, 5-5
- Select the pressure stage 2, see "Chapter 5" 5.4.2, 5-6
- Allow the Drive Unit PPH20** to run for a maximum of 5 seconds
- Switch off the Drive Unit PPH20**, see "Chapter 5" 5.4.4, 5-8
- Wait for 1 minute
- Repeat the start-up and shutdown process three times
- Check the oil level and top up the hydraulic oil as necessary
- Fit tank cover
- The system is now free of air.

7 Corrective maintenance

7.1 Troubleshooting

The following table will help you to narrow down and rectify the source of the fault.

Fault	Possible cause	Solution
Drive Unit PPH20** does not run, although the mains cable is connected	Current phase reversing plug in wrong position (phase pilot lamp lights up)	Change the direction of rotation with the current phase reversing plug see "Chapter 4" 4.2.1, 4-2
	Emergency stop has been activated	Release the Emergency Stop, see "Chapter 5" 5.3.3, 5-4
	No voltage at drive unit because:	
	Automatic circuit breaker in electric controller has tripped	- Reset automatic circuit breaker - Have the mains network checked
	Mains cable is defective	Replace the mains cable
	No voltage at the power supply (building site)	Check power supply
	Phase missing	Check power supply
Drive unit starts up, but then switches off again	Fuse of building site power supply trips	- Fuse protection too weak - Change power supply
	Incorrect voltage	The details on the name plate must correspond to the mains network values (voltage and frequency)
No power, although electric motor is running and valves are open	Defective pump	Have pump replaced by TYROLIT Hydrostress AG or an authorised representative
	Motor direction of rotation is wrong (phase pilot lamp does not light up)	Change the direction of rotation with the current phase reversing plug see "Chapter 4" 4.2.1, 4-2 For drive unit with monitoring Inform TYROLIT Hydrostress AG after-sales service
The hydraulic oil is cloudy, light in colour and the tank overflows	Defective oil cooler	Inform TYROLIT Hydrostress AG after-sales service Warning: Do not continue operating the unit, otherwise hydraulic elements could be damaged
Coupling leaks	- Defective seal - Defective coupling	- Replace seal - Replace coupling

Fault	Possible cause	Solution
The drive unit shuts down suddenly	Power supply interrupted because electric motor or thermal relay has overheated. Reasons: - Undervoltage at the power supply - Overvoltage at the power supply - Cross section of power supply cable too small - Electric motor overheating	Check power supply see "Chapter 1" 1.9.1, 1-6 Check power supply see "Chapter 1" 1.9.1, 1-6 Use mains cable with correct cross section, see "Chapter 5" 5.3.1, 5-2 Allow the motor to cool down
	Defective plug connection	Check plug connection
No pressure build-up in feed circuit	Defective pump	Inform TYROLIT Hydrostress AG after-sales service
	Motor direction of rotation is wrong (phase pilot lamp does not light up)	Change the direction of rotation with the current phase reversing plug see "Chapter 4" 4.2.1, 4-2 For drive unit with monitoring Inform TYROLIT Hydrostress AG after-sales service
No water emerging	Water line is blocked	Clean the water line
	Water valve on feed line is closed	Open water valve
	Insufficient water pressure	Check water circuit see "Chapter 1" 1.10, 1-7

If you are unable to remedy a fault, please call our service centre (see manufacturer's address on the reverse of the title page).

To guarantee a rapid and professional solution to the problem, it is important that you have prepared as follows before calling:

- Try to describe the fault as accurately as possible
- Note the type and index designation of your unit (name plate)
- Have the Operating Instructions close to hand

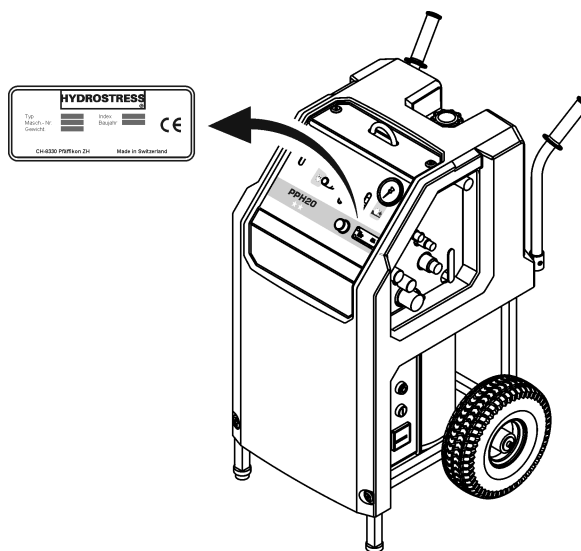

Fig. 7-1 Name plate

7.2 Storage

The Drive Unit PPH20** consists partially of materials which can corrode. If you take the unit out of service for an extended period, proceed as follows:

- Blow out the water from the water lines
- Lightly oil the unit
- Store in a dry location

8 Transport

8.1 Transport

The Drive Unit PPH20** is a high-quality, technical device. Protect it against transport damage:

- Do not place any parts on or against the Drive Unit PPH20**
- Protect the Drive Unit PPH20** from impacts
- The Drive Unit PPH20** must be secured against rolling away during transport

8.2 Safety instructions

It is essential to observe the following safety instructions, especially with regard to transport of the Drive Unit PPH20**.



Danger

Danger from incorrect crane transport.

**Crane transport must only be carried out using the crane suspension shackle provided.
Only undertake crane transport with serviceable building and mobile cranes.**

Failure to observe this regulation may lead to serious physical injury, possibly even death, and to property damage.



Warning

Danger from the lifting of heavy loads.

Units which weight more than 30 kg must not be lifted without suitable equipment.

For transport, use the handles provided. Always keep handles clean and free of grease.

Failure to adhere to this regulation may result in physical injury and damage to property.

8.3 Crane suspension shackle and transport handle

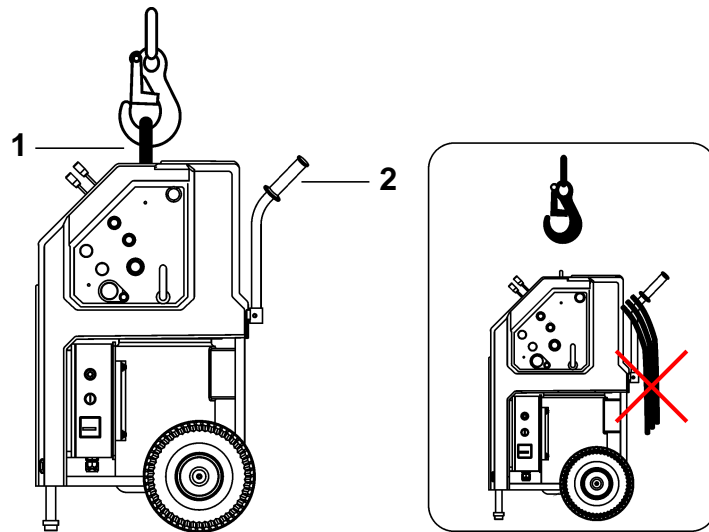

Fig. 8-1 Crane suspension shackle and transport handles

- 1 Crane suspension shackle
- 2 Transport handles with hose bracket



Danger

Danger of falling parts.

When crane transport is used, the Drive Unit PPH20 must be transported alone, (without hoses).**

Failure to observe this regulation may lead to serious physical injury, possibly even death, and to property damage.

9 Disposal

9.1 General

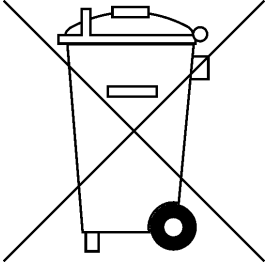

The operator can recycle or dispose of the Drive Unit PPH20** himself provided that he observes the statutory provisions. In order to dismantle the unit correctly and to properly separate the materials, some knowledge of mechanical procedures and knowledge about the differentiation of waste materials is necessary.

Before proceeding, first of all read Chapter 2 "Safety instructions", 2-1 in these Operating Instructions. Be sure also to observe all the danger information given here and follow the instructions on how to prevent personal injury and damage to property.

9.1.1 Safety instructions

It is essential to observe the following safety instructions, especially in relation to disposal of the Drive Unit PPH20**.



Danger

Danger of falling heavy parts.

When performing the types of work described in this chapter, it is absolutely essential to wear the following personal protective equipment: goggles, protective gloves and safety shoes.

It is essential to ensure that the work instructions and procedures described in this safety manual are followed.

Failure to observe this regulation may lead to serious physical injury, possibly even death, and to property damage.

9.1.2 Personnel qualifications

Personnel who carry out the work described in this chapter must meet the following conditions:

- Have read and understood the safety instructions in "Chapter 2".
- Have completed their technical training (mechanical/electrotechnical) and are in a position to differentiate the various material groups.

9.2 Disposal regulations

The usual national and regional regulations and directives must be observed when disposing of the Drive Unit PPH20**.

9.3 Disposal of the Drive Unit PPH20**

To allow proper disposal, the components of the Drive Unit PPH20** must be dismantled. This is performed by the client's personnel.

The dismantled parts of the device are sorted by material type and sent separately to the appropriate collection points. Ensure, above all, that the following parts are correctly disposed of.

The Drive Unit PPH20 consists of the following materials:**

Cast aluminium	Rolled aluminium products
Copper	Steel
Rubber	Rubber / nylon fabric
Synthetic grease	Hydraulic oil
Plastic	